

G. Loebenstein
G. Thottappilly
Editors

Agricultural Research Management



Springer

AGRICULTURAL RESEARCH MANAGEMENT

Agricultural Research Management

edited by

G. Loebenstein

*Agricultural Research Organization,
Bet Dagan,
Israel*

and

G. Thottappilly

*Sahrdaya College of Engineering and Technology,
Kodakara, Kerala,
India*



Springer

A C.I.P. Catalogue record for this book is available from the Library of Congress.

ISBN 978-1-4020-6056-4 (HB)
ISBN 978-1-4020-6057-1 (e-book)

Published by Springer,
P.O. Box 17, 3300 AA Dordrecht, The Netherlands.

www.springer.com

Printed on acid-free paper

All Rights Reserved
© 2007 Springer

No part of this work may be reproduced, stored in a retrieval system, or transmitted in any form or by any means, electronic, mechanical, photocopying, microfilming, recording or otherwise, without written permission from the Publisher, with the exception of any material supplied specifically for the purpose of being entered and executed on a computer system, for exclusive use by the purchaser of the work.

CONTENTS

Contributors	vii
Preface	xi
Color Plates	xiii
General	
1. The Mission of Agricultural Research <i>G. Loebenstein and G. Thottappilly</i>	3
2. The Mission and Evolution of International Agricultural Research in Developing Countries <i>F.J. Morales</i>	9
3. Considerations for Determining Research Priorities: Learning Cycles and Impact Pathways <i>M.C.S. Bantilan and J.D.H. Keatinge</i>	37
4. Creating an Effective Process to Define, Approve, and Review the Research Agenda of Institutions in the Developing World <i>R. Ortiz and J. Crouch</i>	65
5. The Research Department and Institute <i>S. Navarro and G. Loebenstein</i>	93
6. Leadership in Agricultural Research Management <i>Jacqueline d'Arros Hughes</i>	101
7. Bioethics in Agricultural Research and Research Management <i>Annabel Fossey</i>	121

8. The Contribution of Information and Communication Technologies (ICT) to the Management of Publicly Funded Agricultural Research <i>E. Gelb and D. Levanon</i>	149
9. Harness of R&D for the Benefit of a Practical-Oriented Organization <i>I. Spharim</i>	169
Case Studies	
10. CGIAR – The Consultative Group on International Agricultural Research <i>E. Hartmans and Gun Lundborg</i>	187
11. Linking Priorities and Performance – Management of the USDA Agricultural Research Service Research Portfolio <i>E.B. Knipling and C.E. Rexroad, Jr.</i>	213
12. Agricultural Research Management in US Land-Grant Universities – The State Agricultural Experiment Station System <i>Donald A. Holt</i>	231
13. USDA-CSREES National Research Initiative: Support for Agricultural Research – The competitive grants program in the United States <i>Chavonda Jacobs-Young, M.A. Mirando, and Anna Palmisano</i>	259
14. Agricultural Research Governance and Management in Nigeria <i>N.O. Adedipe</i>	271
15. INRA – National Institute for Agricultural Research – From the Local to the Global Levels <i>M. Dodet</i>	285
16. The Indian Agricultural Research System <i>M.S. Swaminathan and S. Bala Ravi</i>	305
17. Agricultural Science in the Netherlands <i>K. Verhoeff, C. Mollema, and R. Rabbinge</i>	331
18. Agricultural Research in Israel <i>G. Loebenstein and E. Putievsky</i>	357
19. Concluding Remarks <i>G. Thottappilly and G. Loebenstein</i>	367
Index	379

CONTRIBUTORS

N.O. Adedipe

*Department of Crop Protection and Environmental Biology,
University of Ibadan, Ibadan, Nigeria
E-mail: noadedipe@yahoo.com*

S. Bala Ravi

*M.S. Swaminathan Research Foundation, Third Cross Road,
Institutional Area, Taramani, Chennai 600 113, India
E-mail: sbala@mssrf.res.in*

Cynthia Bantilan

*International Crops Research Institute for the Semi-Arid Tropics (ICRISAT),
Patancheru 502324, Andhra Pradesh, India
E-mail: c.bantilan@cgiar.org*

J. Crouch

CIMMYT, Apdo. Postal 6-641, 06600 Mexico D.F., Mexico

M. Dodet

*INRA, 147 rue de l'Université, 75338 Paris Cedex 07 France.
E-mail: michel.dodet@paris.inra.fr*

Annabel Fossey

*Forestry, Natural Resources and the Environment, CSIR, P.O. Box 17001,
Congella, Durban 4013, South Africa
E-mail: afossey@csir.co.za*

E. Gelb

*Former CIO, Israeli Ministry of Agriculture and Rural Development;
E-mail: gelb@agri.huji.ac.il*

E. Hartmans

*Former Director General if IITA
E-mail: ermondh@web.de*

D.A. Holt

*Senior Associate Dean, Retired; Professor Emeritus of Crop Sciences; College of Agricultural, Consumer, and Environmental Sciences; University of Illinois
E-mail: d-holt@uiuc.edu*

Jacqueline d'Arros Hughes

*AVRDC – World Vegetable Centre, PO Box 42, Shanhua, Tainan 74199, Taiwan
E-mail: j.hughes@netra.avrdc.org.tw*

Chavonda Jacobs-Young

*Competitive Programs Unit, Cooperative State Research, Education, and Extension Service, US Department of Agriculture, Washington, DC 20250-2241, USA
E-mail: cjacobs@csrees.usda.gov*

J.D.H. Keatinge

*International Crops Research Institute for the Semi-Arid Tropics (ICRISAT), Patancheru 502324, Andhra Pradesh, India
E-mail: d.keatinge@cgiar.org*

E.B. Knipling

*Administrator Agricultural Research Service, US Department of Agriculture, Beltsville, Maryland, USA
E-mail: eknipling@ars.usda.gov*

D. Levanon

*Chief Scientist, Israeli Ministry of Agriculture and Rural Development;
E-mail: danl@moag.gov.il*

G. Loebenstein

*Agricultural Research Organization, Volcani Center, Bet Dagan 50-250, Israel.
E-mail: Gad-talma@barak.net.il*

Gun Lundborg

*Scientific writer
E-mail: lundborg@alice.it*

M.A. Mirando

Competitive Programs Unit, Cooperative State Research, Education, and Extension Service, US Department of Agriculture, Washington, DC 20250-2241, USA

E-mail: mmirando@csrees.usda.gov

C. Mollema

Senior officer Wageningen University and Research Centre; currently Radboud University, Nijmegen, The Netherlands

E-mail: chris.mollema@planet.nl

F.J. Morales

International Centre for Tropical Agriculture (CIAT), AA 6713, Cali, Colombia

E-mail: f.morales@cgiar.org

S. Navarro

Agricultural Research Organization, Volcani Center, Bet Dagan 50-250, Israel

E-mail: snavarro@int.gov.il

R. Ortiz

CIMMYT, Apdo. Postal 6-641, 06600 Mexico D.F., Mexico

E-mail: r.ortiz@cgiar.org

Anna Palmisano

Competitive Programs Unit, Cooperative State Research, Education, and Extension Service, US Department of Agriculture, Washington, DC 20250-2241, USA

E-mail: apalmisano@csrees.usda.gov

E. Putievsky

Agricultural Research Organization, Volcani Center, Bet Dagan 50-250, Israel

E-mail: elip@volcani.agri.gov.il

R. Rabbinge

University professor, Wageningen University & Research Centre. Wageningen The Netherlands

E-mail: rudy.rabbinge@wur.nl

C.E. Rexroad Jr.

Associate Administrator Agricultural Research Service, United States Department of Agriculture, Beltsville, Maryland, USA

E-mail: caird.rexroad@ars.usda.gov

I. Spharim

Formerly, Economic division of the Agricultural Research Organization, Bet Dagan, Israel; Presently economic advisor to the Jerusalem Outline Program 2000.

E-mail: nuritat@netvision.net.il

M.S. Swaminathan

M.S. Swaminathan Research Foundation, Third Cross Road, Institutional Area, Taramani, Chennai 600 113, India

E-mail: msswami@vsnl.net

G. Thottappilly

Sahrdaya College of Engineering and Technology, Kodakara, P.O., Thrissur 680 684, Kerala, India

E-mail: george_thottappilly@rediffmail.com; g.thottappilly@sify.com

K. Verhoeff

Former director Science & Technology, Ministry of Agriculture, Nature Management & Fishere; The Netherlands.

E-mail: k.verhoeff@planet.nl

PREFACE

Agricultural research is one of the oldest and most widespread forms of organized research in the world, in both developed and developing countries. Starting by the middle of the 19th century, organized agricultural research was taking place in institutions such as the Agricultural Chemistry Association of Scotland, the Agricultural Experiment Station, Saxony, and the Land Grant Colleges in the United States, leading within 150 years to a tremendous increase in food production.

Management of agricultural research involves many decisions that have scientific, social and political consequences. Every country has established agricultural research priorities based on many complex factors that must be considered when decisions are made on the choice of research problems to be investigated. Resources must be divided among projects that often compete for the limited funding available that supports the total research enterprise. Wishes by stakeholders have to be considered as well as the aspirations of the individual researcher. A wise management will try to accommodate both. In addition, a system of incentives for the researcher (and his technicians) to promote first class research within the mandate of the institute will promote their output. Advancement based on merit and achievements is a necessity also in government institutes not to be bound by regular civil service regulations. These have to be handled by independent promotion committees, including scientists from other institutions, to prevent favoritism.

Periodic reviewing of research units should become an integral part of the agricultural research management. It is advisable to include outside scientists as well as some farmers or extension specialists in the review board.

In this book various research systems from different countries are represented. Each country developed its own system according to the local conditions and

necessities. However, it should be possible to adopt practices from one country into the local system.

Due to reduced funding by governments (or parent organizations) many institutions rely on external grant funding. To a certain extent this may be welcome, as it requires the researchers to compete on the global market. However, grant funding should not be more than 30% of the total; otherwise the main mandate of the institute will be neglected.

The reduced funding for agricultural research in many of the developed countries and their agencies should be reconsidered; especially as population increases on the globe forecast a severe food shortage. The wise management of resources for agricultural research will therefore be of major importance. We hope that this book will be of some value in this direction.

Gad Loebenstein

George Thottappilly
April 2007

COLOR PLATES

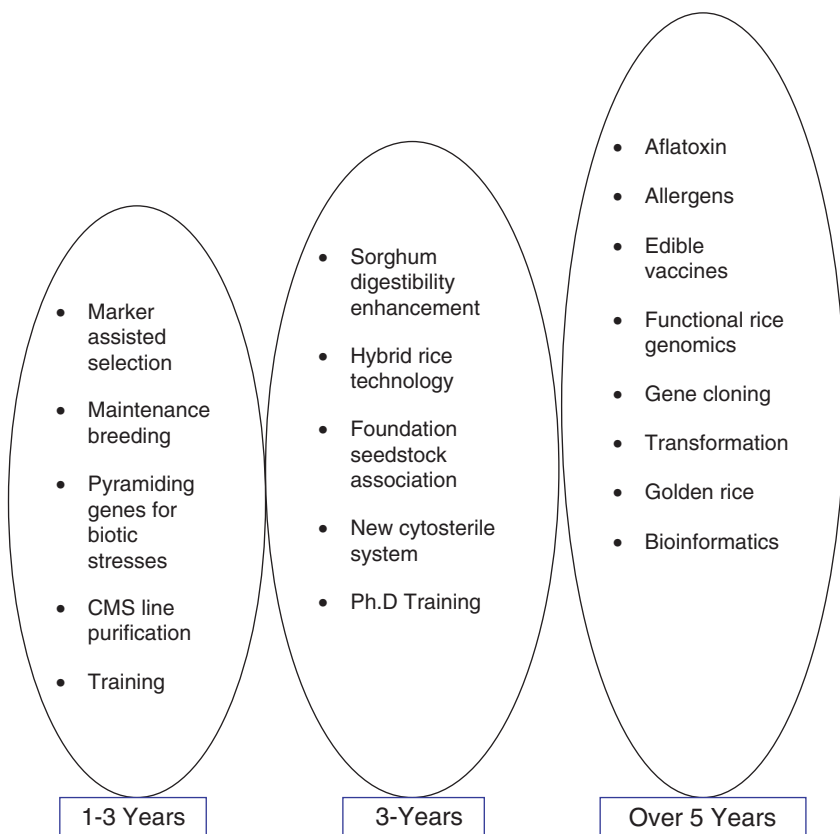

Plate 1 Short, intermediate and long term projects. (Present as Figure 1 in Chapter 1)

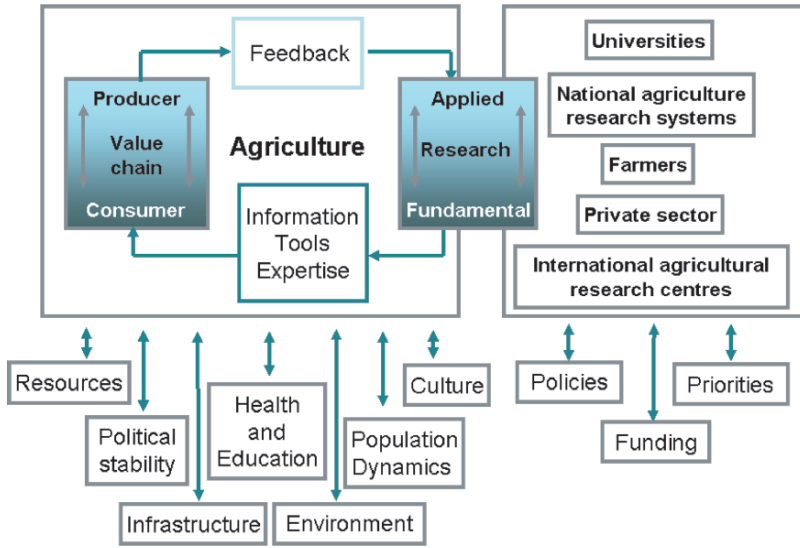

Plate 2 Complexity in agricultural research and the interactions that have to be orchestrated to ensure visionary leaders for agricultural research management. (Present as Figure 1 in Chapter 6)

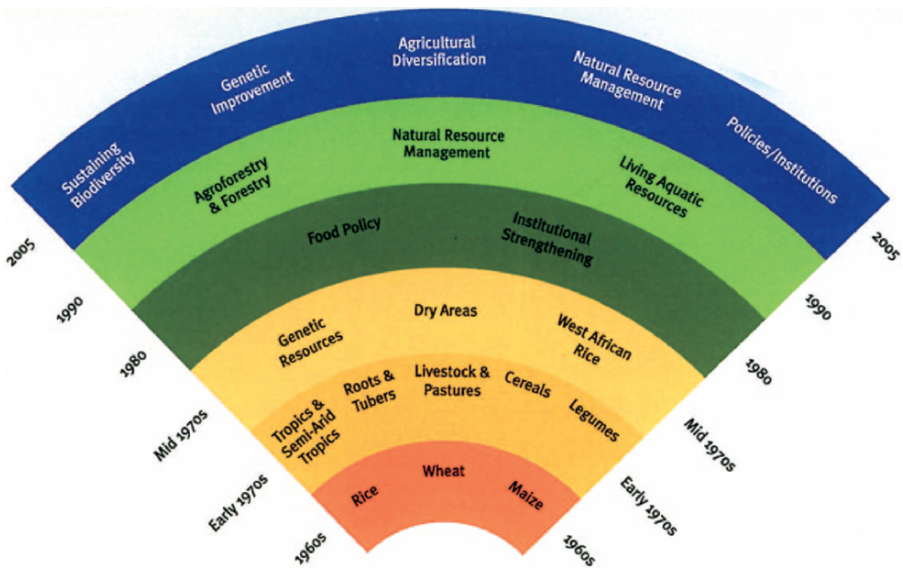

Plate 3 CGIAR research agenda with the year in which mandate was initiated. (Present as Figure 1 in Chapter 10)



Plate 4 Map showing headquarters and other locations of CGIAR centers. (Present as Figure 2 in Chapter 10)



Plate 5 ARS locations. (Present as Figure 1 in Chapter 11)

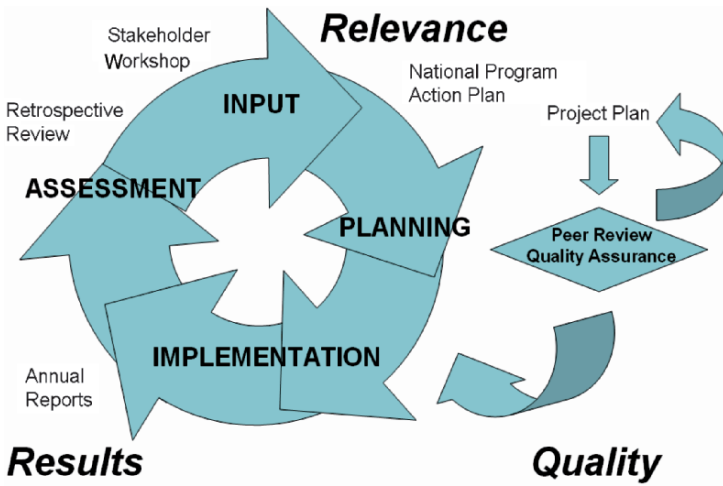

Plate 6 ARS 5-year research program cycle. (Present as Figure 2 in Chapter 11)

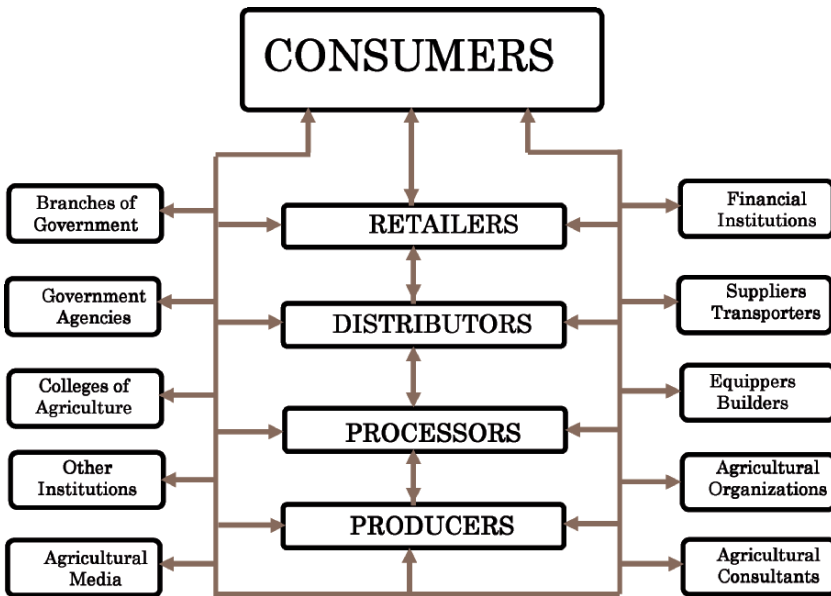

Plate 7 Diagram depicting the flow of products and information within the food and agriculture sector. (Present as Figure 1 in Chapter 12)

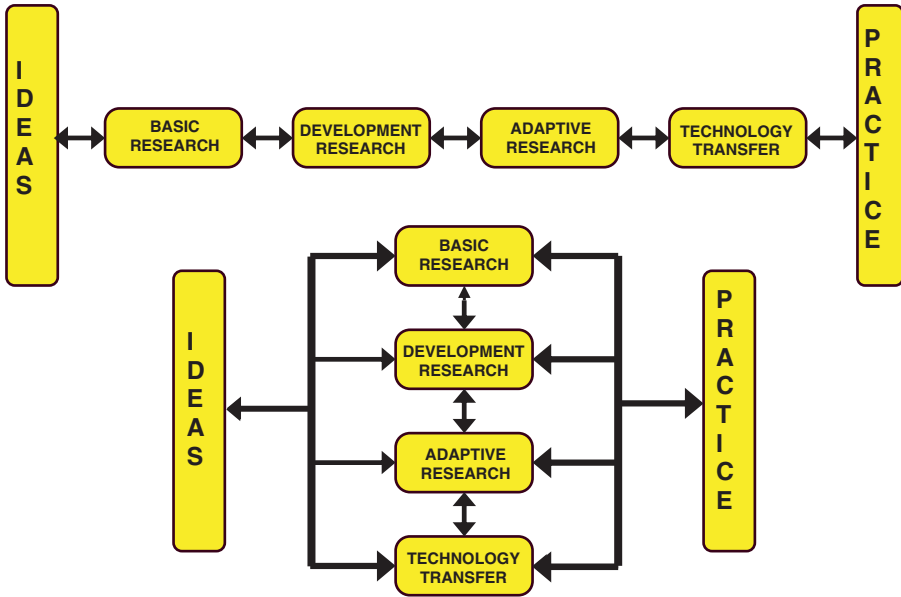

Plate 8 Two organizational paradigms of agricultural research. Upper diagram depicts linear organization of research and development (R&D) functions linking ideas to commercial practise. Lower diagram depicts parallel organization of R& D functions. (Present as Figure 3 in Chapter 12)

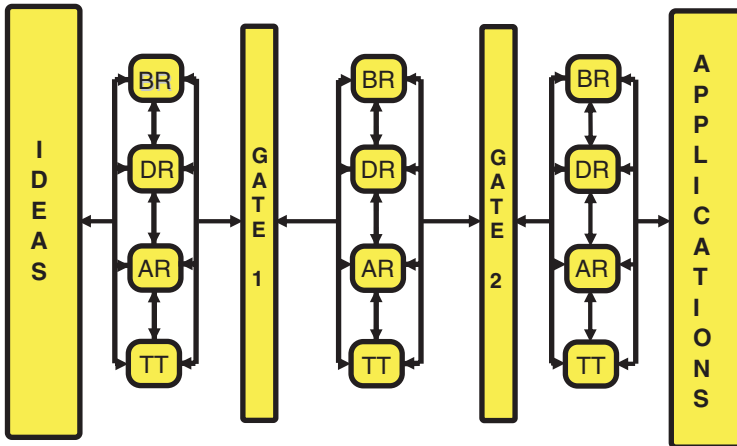

Plate 9 Diagram depicting the stage - gate paradigm of agricultural research organization. (Present as Figure 4 in Chapter 12)

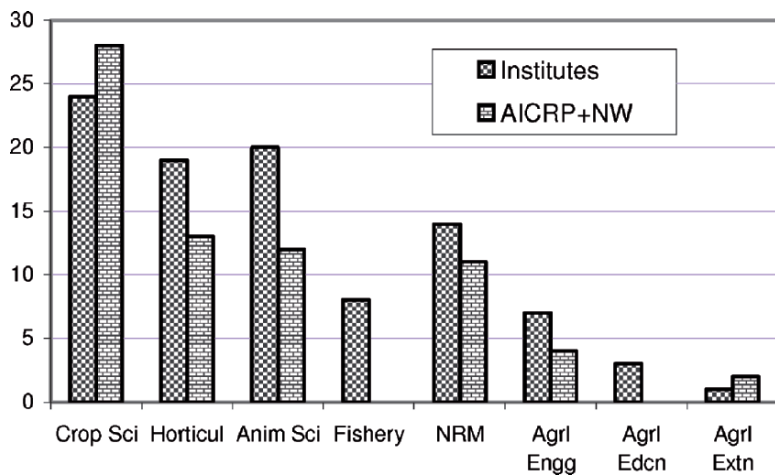

Plate 10 Number of institutes and coordinated research programmes under each division of the ICAR. (Present as Figure 3 in Chapter 16)

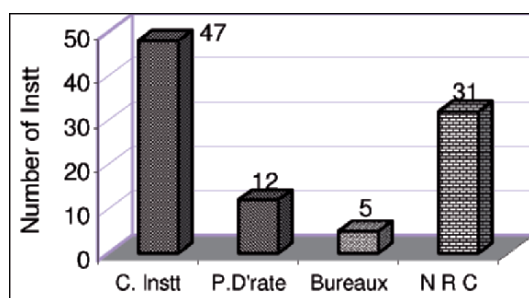

Plate 11 Profile of the research and educational institutes under the ICAR. (Present as Figure 4 in Chapter 16)

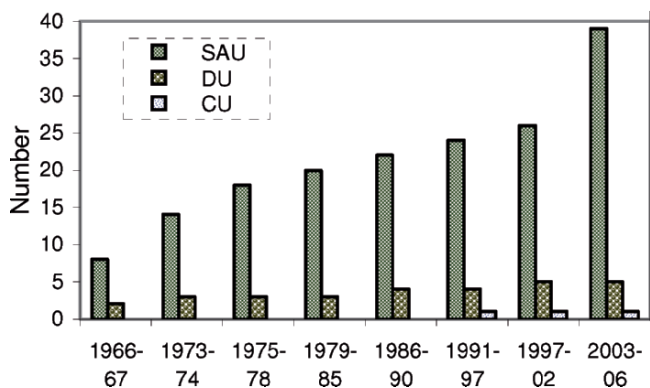
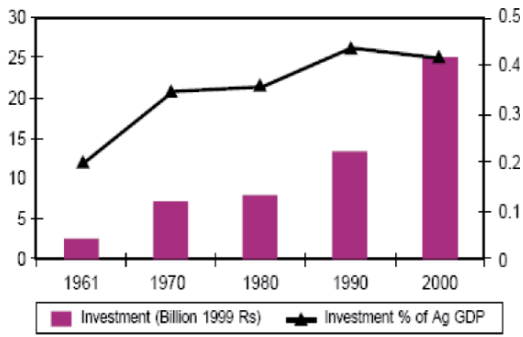

Plate 12 Growth of State Agricultural Universities, Deemed Universities and Central Universities in India. (Present as Figure 5 in Chapter 16)



Source: Pal, Mathur and Jha, 2005

Plate 13 Funding to Agricultural Research and Education in India during last four decades. (Present as Figure 6 in Chapter 16)

PART I
GENERAL

CHAPTER 1

THE MISSION OF AGRICULTURAL RESEARCH

GAD LOEBENSTEIN¹ AND GEORGE THOTTAPPILLY²

¹*Agricultural Research Organization, Volcani Center, Bet Dagan 50-250, Israel;* ²*Dean of Studies, Biotechnology, Sahrdaya College of Engineering and Technology, Kodakara, PO, Thrissur 680 684, Kerala, India*

Agricultural research seems to be the oldest form of organized research in the world. Agricultural research can be broadly defined as any research activity aimed at improving productivity and quality of crops by their genetic improvement, better plant protection, irrigation, storage methods, farm mechanization, efficient marketing, and a better management of resources.

Since the middle of the 18th century attempts were made to apply scientific knowledge to improvement of agriculture. By the middle of the 19th century, organized agricultural research was taking place in the Agricultural Chemistry Association of Scotland and the Agricultural Experiment Station, Moekern, Saxony. During the first half of the 20th century, most industrialized countries developed systems for agricultural technology development. It is generally believed that investment in agricultural research will result in beneficial returns (Asopa and Beye, 1997).

The definition of the mission of agricultural research has varied over the years. In the 1960s Aldrich (1966) included in it: “To apply all possible sources of scientific discovery to the solution of the technical and practical problems of agriculture; to engage in basic research where the lack of fundamental knowledge may impede progress; and to solve the specific problems with which agriculture is faced.” In essence, the mission of agricultural research was to increase yields and stability in yields over the years.

During the last decade the mission of agricultural research has been defined in greater detail, considering not only yields, but also other factors as sustainability of resources and effects on the environment. Research aimed at better varieties, plant nutrition, and water use as well as agricultural economics and farm management is an important component of agricultural research and the sustainable utilization of resources for the benefit of humanity and the environment.

The global mission of agricultural research will be to feed the ever-increasing population from 6.4 billion (2005) to an expected 9.4 billion in 2030. This can

only be achieved if agricultural and biological research come up with novel technologies, both conventional and biotechnological, which will increase food yields substantially in present and marginal environments.

The missions and goals of agricultural research vary between highly developed and developing countries, and between countries in each category. Generally it can be said that the overall mission of agricultural research is to increase efficiency of agricultural production and its quality, enabling a decent income and living to the farmer, and taking into account the ecological and social constraints.

An example of the mission of agricultural research in an industrial nation is that from the United States (<http://www.cprl.ars.usda.gov>):

- Protecting crops and livestock from pests and disease
- Improving the quality and safety of agricultural products
- Determining the best nutrition for people from infancy to old age
- Sustaining soil and other natural resources
- Ensuring profitability for farmers and processors
- Keeping costs down for consumers

In other developed countries missions are not presented in such detail. For example, the French Agricultural Research Organization (INRA) defines its mission thus: “To provide solutions to current and potential (agricultural) problems of major significance. To ensure better nutrition for people and preserve their health. To sensibly develop and manage land and the environment. To promote scientific and technological innovation, particularly in the life sciences, while remaining vigilant and responsible. To understand and control the complexity of our biological, economic, and social systems”.

It is interesting to note that development of knowledge for long-term needs, versus current and medium-term knowledge needs, is now being more and more emphasized, as in the United States and the Netherlands (<http://www.agro.nl/nrlo/>). Thus, new terms are now being introduced such as “sustainable development” in addition to economic, ecological, social, cultural, technological, and spatial elements. New possible combinations of highly diverse functions (agriculture, recreation, nature, housing, infrastructure, water collection, etc.) will have to be integrated, and agribusiness and green space will be part of the mission of agricultural research. Thus, in the future, distinctions between fundamental researches, strategic research, applied research, and practical research will decrease.

In developing countries the mission varies according to their, mostly short-term, needs. In the last 40 years food availability in the world has changed in both quality and quantity. Regions like Asia which were considered to have attained self-sufficiency are again becoming importers of food, due to their rapidly increasing populations. Africa remains deficient in local food supply, and the gap between food production and need is widening markedly.

The primary goal of agricultural research is to support agricultural and rural development by proposing technical innovations adapted to the physical and socio-economic conditions and providing technical information as soil maps, inventory of biological resources, surveys of farms, pests and diseases, etc.

(Asopa and Beye, 1997b). Thus, for example, the mission and mandate of agricultural research in India includes *inter alia* increasing agricultural production and productivity, to ensure food security for the rising population; developing areas of untapped potential, thereby correcting imbalances in growth in eastern hilly rain-fed and drought-prone regions; meeting challenges of degradation of land and water resource, and emerging ecological imbalances, due to increases in biotic pressure on land; addressing problems of underemployment and malnutrition through diversification of agriculture and promotion of horticulture, fisheries, dairy, and livestock; encouraging use of marginal lands and biomass production through forestry (Asopa and Beye, 1997).

The mission of agricultural research in Kenya may serve as an example for Africa. Some 80% of the Kenyan population lives in rural areas, and 75% is somehow involved in agriculture. Kenya's economy is therefore heavily dependent on its agricultural productivity. Over the last decade, however, agricultural productivity has declined and poverty has increased. The agricultural research mission is designed to cultivate more efficient market-driven production of maize, dairy, and horticultural commodities by (a) increasing agricultural productivity through research, development, and transfer of improved agricultural technologies including support for improved technologies in maize, dairy, horticultural varieties, as well as biotechnology, biosafety, and appropriate technologies; and (b) conservation of sustainable natural resources for agriculture.

The Mission of the Consultative Group on International Agricultural Research (CGIAR) is to mobilize science to benefit the poor. The individual institutes have listed the following missions:

- ICARDA: Science that improves and integrates the management of soil, water, nutrients, plants, and animals in ways that optimize sustainable agricultural production.
- CIMMYT: To act as a catalyst and leader in a global maize and wheat innovation network that serves the poor in developing countries. Drawing on strong science and effective partnerships, we create, share, and use knowledge and technology to increase food security, improve the productivity and profitability of farming systems, and sustain natural resources (<http://www.cimmyt.org>).
- ICRISAT: To help the poor of the semi-arid tropics through Science with a Human Face and partnership-based research for development to increase agricultural productivity and food security, reduce poverty, and protect the environment in semi-arid production systems (www.icrisat.org).
- IITA: The theme is "working to enhance food security, income and the well-being of the people in Sub-Saharan Africa".

In certain countries the mission for agricultural research may also include the development of crops and technology for settling new areas and research for developing crops and methods for exports.

It is also important to indicate in the mission statement whether projects come under short-term (less than 3 years), medium-term (3–10 years), or long-term (over 10 years) objectives as shown in Figure 1.

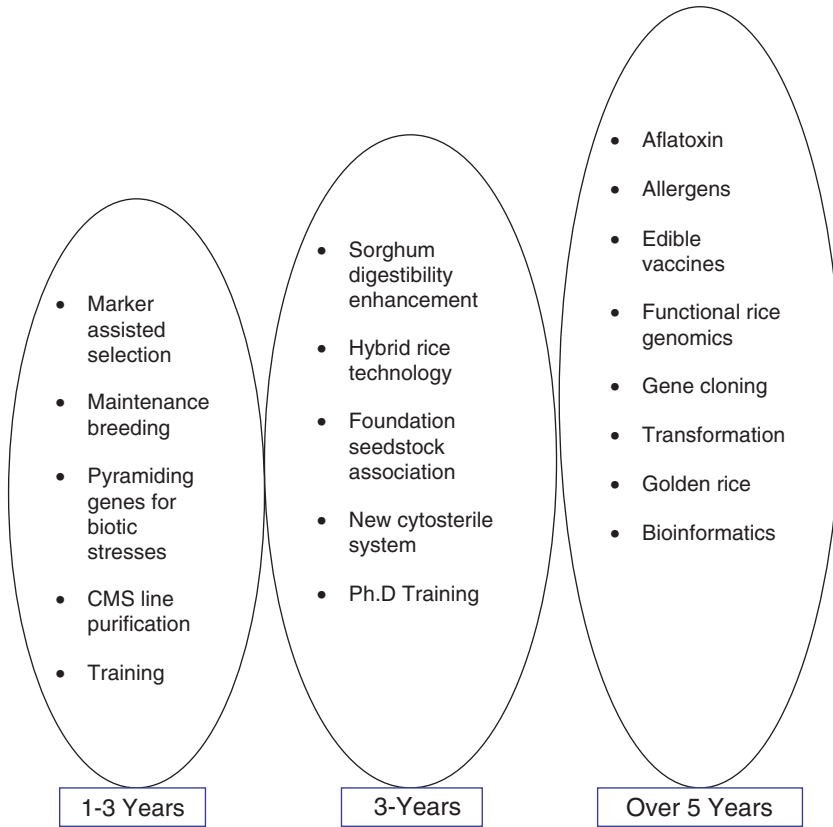

Figure 1. Short, intermediate and long term projects. (see Color Plate 1 following p. xiii.)

IN CONCLUSION

The mission of agricultural research as a science is to increase productivity of food and fibre crops (and in the foreseeable future also bio fuel), which are consumer-sensitive and profitable to the farmers in environmentally safe systems. However, each organization has to define its specific comprehensive mission adapted to its particular environment. The definition of mission in every organization is always broad including all the aspects and areas needed. Nevertheless, a wise administration of the particular system will in addition define from time to time priority areas, which should be strengthened and supported preferentially.

REFERENCES

- Aldrich, D.G. 1966. Agricultural Research, a Key to Understanding our Environment. In: *Symposium on Research in Agriculture*. USDA, Agricultural Research Service, Washington, DC, pp. 50–53.
- Asopa, V.N., and Beye, G. 1997. Management of Agriculture Research. A Training Manual. FAO. Rome.

Anonymous 1999. INRA, from the molecule to the marketplace. INRA Scientific Information and Communication Directorate.

Asopa, V.N., and Beye, G. 1977a. Institutional Agricultural Research: Organization and Management. Module 1 Exhibit 3. FAO, Rome, Italy.

Asopa, V.N., and Beye, G. 1977b. Institutional Agricultural Research: Organization and Management. Module 2 . FAO, Rome, Italy.

CHAPTER 2

THE MISSION AND EVOLUTION OF INTERNATIONAL AGRICULTURAL RESEARCH IN DEVELOPING COUNTRIES

FRANCISCO J. MORALES

Coordinator Tropical Whitefly IPM Project, Head Virology Research Unit, International Centre for Tropical Agriculture (CIAT), AA 6713, Cali, Colombia

THE DAWN OF AGRICULTURAL RESEARCH

The history of all nations began over half a million years ago, when different groups of primitive people left Africa to populate the rest of the world. It took almost that much time before *Homo sapiens* could initiate the process of domestication of plants, in order to feed a growing, sedentary population. In fact, this process began *c.*10,000 years ago, because 70,000–13,000 years ago, most of the water was in the form of ice sheets (glaciations) that covered the current temperate regions, while the tropics were dry (Goldammer and Seibert, 1989). Once the ice melted and the rainfall and temperature increased, the process of plant domestication could be initiated to produce the first staples: einkorn wheat (*Triticum monococcum*), emmer wheat (*T. turgidum*), and barley (*Hordeum vulgare*) in the Near East; rice (*Oryza sativa*) in Asia; maize (*Zea mays*), beans (*Phaseolus* spp.), and potato (*Solanum* spp.) in Latin America; African rice (*Oryza glaberrima*), pearl millet (*Pennisetum glaucum*), and sorghum (*Sorghum bicolor*) in Africa, that made possible the emergence of the first civilisations of the world (Smith, 1998). The early inhabitants of the tropical, subtropical, and Mediterranean regions were the real artifices of the first “agricultural revolution”. The civilisations that developed later on in Europe, appropriated most of the domesticated plants and agricultural knowledge developed in the regions currently occupied by the so-called “developing nations”.

If agriculture and agricultural research were first developed in today’s developing nations, one wonders what truncated the process of agricultural research and development (R&D) in these nations? Perhaps the answer can be found in the history of the first great civilisations, which eventually succumbed to aggressive migrant

tribes in search of food and riches. Even the Greeks and the Romans, conquerors of other foreign cultures, eventually succumbed to the invasion of nomadic tribes that originated in Asia, Northern and Eastern Europe. These migrant hordes were fortunately contained in Western Europe and, ever since, this region has prevailed over the rest of the devastated early civilisations of the Old World. Following the defeat of the Moors by Charles Martel at the battle of Tours in 732, the victorious Carolingian dynasty of Western Europe became the leading power in the Western world. This victory changed the course of history and made possible the accumulation of the knowledge generated by the major ancient cultures of the Middle East, North Africa, Greece, and Asia, in Western Europe (Kreis, 2006). The application and further refinement of this knowledge, eventually allowed the main European nations to conquer and colonise the rest of the world in order to seize control of their natural resources and expand their dominions.

History books say that America was “discovered” in 1492 by Christopher Columbus, in the name of the Spanish Crown, and some say that the American natives were still in the “Stone Age” when the Spaniards conquered this continent. These historical accounts neglect to mention the fact that the aboriginal cultures of the Americas had been in this region for over 12,000 years before the Spanish arrived in this continent. Highly advanced pre-Hispanic cultures, such as Valdivia, Chavín, Olmec, Mayan, Toltec, Aztec and Inca, had independently developed basic astronomical, mathematical, and architectural knowledge, at least 2,000 years before Spain became a nation. More important, these civilisations had domesticated and genetically improved some of the major crops grown today in the world, including: maize, beans, potato, cucurbits, cocoa, pineapple, sweet potato, cassava, peanut, papaya, tomato, peppers, cotton, and rubber, just to mention some important neo-tropical crops. The European conquest of less-developed nations in the Americas, Africa, and Asia, continued well into the 20th century, and eventually led to the industrialisation of Europe (Harris, 1972; Mason, 2000). In the 1920s, the British Empire occupied nearly 25% of the surface of this planet. Europe had thus increased its main production factors: land, capital, and labour, the latter being provided mainly by native American, African, and Asian slaves.

AGRICULTURE IN COLONIAL TIMES

Following the voyages of “discovery” undertaken in the 15th century by European explorers, practically all of the developing countries of Asia, Africa, and Latin America became colonised. As mentioned above, the purpose of colonisation was to appropriate valuable natural resources, mainly minerals (e.g. gold, silver, gems) and agricultural commodities, such as spices, coffee, tea, cocoa, cotton, tobacco, and medicinal plants. To this end, large areas of land were invaded and then assigned, leased, or sold to European settlers, who used slaves and primitive technologies to exploit the newly conquered and extensive

landholdings. In Latin America, the “encomienda” system allowed Spanish settlers to exercise total control over the aboriginal communities reducing them to total slavery. The productivity of these extensive “haciendas” was usually low per unit area, and was characterised by a “subsistence” agriculture practised by the enslaved local population. This inefficient agricultural system, referred to as “latifundismo” in Latin America, was still common in the middle of the 20th century. The more intensive “plantation” agriculture, also involved rather primitive agricultural practices, even though the use of draft animals to till the land was considered a major improvement in Latin America, where pre-Hispanic societies did not have draft animals. Furthermore, agriculture was heavily taxed in colonial Latin America, to discourage the development of an agricultural industry that could eventually compete with agricultural products imported from Spain (Halperin, 1990).

As in the case of Latin America, the colonial system in Africa gave land to settlers, who could make use of the cheap labour provided by the dispossessed local communities. European policy favoured white settlers, particularly in countries such as Kenya, South Africa, and Zimbabwe. In the Belgian Congo, the land was owned by the state, and African labourers who did not meet their harvest quotas, could be severely punished and even executed (Harris, 1972).

In 1498, the Portuguese reached India, thus beginning European infiltration of Asia. Towards the end of the 18th century, India was under British control. The British extended their dominion to Malaysia. In 1618, the Dutch took over Indonesia, and the French took over Vietnam, Cambodia, and Laos (French Indo-China). The Philippines were already a Spanish colony since 1565.

The belief that Asians, American aborigines, and blacks were inferior human beings was the central dogma of the European colonial mentality. Philosophical rationalisation for the exploitation of other races in the 18th century was widely accepted and supported even by the notable Swedish botanist Carolus Linnaeus (Hudson, 2002).

INDEPENDENCE AND AGRICULTURAL DEVELOPMENT

Latin America was the first region, after the United States, to gain independence from Europe, namely Spain and Portugal. Understandably, a vast impoverished region without any industrial capacity, had to fall back into the commercial dominion of other European powers, such as England and France. In fact, unpaid commercial debts contracted by Mexico with France and other European powers in the 19th century, led to the invasion of Mexico by the French army, and the establishment of an imperial government headed by Maximilian of Austria in 1864 (Halperin, 1990).

Towards the mid-1900s, the United States emerges as the dominant power in the Americas. Independent Latin America had not recovered in 1850 from three

centuries of colonial exploitation. Only Argentina managed to recover thanks to their cattle industry and the production of cereals. In most of Latin America, the “latifundio” system persisted.

The independence of Latin America from Spain and Portugal was the beginning of a prolonged series of internal conflicts, civil wars, and territorial aggressions among neighbours. Moreover, the dominant “criollo” class (Europeans born in the Americas) consolidated their occupation and control of the large areas corresponding to the colonial “resguardos” or “encomiendas” (native reservations exploited by Europeans). The independent countries and their landlords continued the “plantation” agricultural system in the 19th century. For instance, in Brazil, 40% of the commercial trade was based on the export of sugar to Great Britain, with cotton and coffee being in second and third places. During this period (1830–1850), labour was provided mainly by black slaves (Mörner, 1970).

In 1910, Mexico was at the brink of civil war over the distribution of agricultural land. The extensive “haciendas” still maintained a “legalised” system of peasant labour in exchange for food and other basic needs of the rural poor. In Central America, independence did not bring any improvement in the livelihoods of millions of aborigines practising subsistence agriculture. In the rest of Latin America, traditional export crops, such as tobacco, cotton, and cocoa, formed the basis of their incipient economies. The southern cone of Latin America, particularly Argentina and Chile, had a predominant European population and extensive holdings that produced more profitable crops, such as wheat, grapes, and other fruit crops, besides the large cattle industry that occupied the extensive “pampas” of Argentina (Halperin, 1990).

The independence of many Asian and African countries took place around the mid-1990s, but the situation was very similar to that of Latin America. Impoverished countries left to their destiny, without much education in the rural areas, industry, or a land tenure system that allowed any significant agricultural development.

In summary, most developing economies entered the 20th century with over 50% of their population in rural areas, and over 40% of the landholdings occupying less than 2% of the agricultural land. In Latin America, 50% of the farms had less than 5 hectares in 1990 (CEPAL, 2001). Export commodities were few and often accounted for over 90% of total agricultural exports, as in the case of coffee. The scarcity or lack of land has been identified as one of the main causes of persistent poverty in developing countries. In Africa, the short-term effect of education in rural communities was the migration of the educated to urban centres (Odhiambo, 2001). The traditional food staples were left in the hands of the small-scale farmers, without any technological assistance, just to satisfy the internal demand (Colombian Ministry of Agriculture, 2001).

NATIONAL AGRICULTURAL RESEARCH SYSTEMS

The history of agricultural research in Latin America is closely linked to the history of agricultural sciences in Europe. In the 16th century, several European universities, such as Heidelberg, Leiden, Pisa, and Montpellier, included the study

of plants as part of the career of medicine, mainly for their pharmaceutical properties. In the 1790s, the Universities of Edinburgh and Oxford, in the United Kingdom, taught some elementary courses on agriculture and agricultural economics. In 1840, a publication entitled “Organic Chemistry and its Relation to Agriculture and Physiology”, published by Justus von Liebig at the University of Giessen, Germany, is considered one of the first treatises on agricultural research in Europe. The Experimental Agricultural Station of Alsace, France, was founded in 1834. In England, the first independent agricultural research stations, such as Rothamsted (1843), were founded towards the middle of the 19th century. These stations were later financed by the state and industry, because they were created mainly to conduct research on the use and commercial applications of plants ([www/rothamsted.bbsrc.ac.uk](http://www.rothamsted.bbsrc.ac.uk)).

The search for plants of commercial value began in colonial times, when botanical expeditions planned in Europe in the late 18th century (1777–1786), explored countries such as Chile, Peru, Ecuador, Colombia, Central American nations, and Mexico. These expeditions included some Latin American staff, which learned the rudiments of botanical science on the job. One of the most famous directors of the botanical expeditions that took place in Colombia, was Jose Celestino Mutis, a Spanish medical doctor, who initiated the teaching of agricultural sciences in Colombia in 1802 (Restrepo et al., 1993). The voyages of “discovery” also continued well into the 19th century, and usually included botanists. Exotic plant species began to be collected and studied in various private and state-owned botanical gardens of Europe in the 15th century.

The newly independent countries of Latin America, and the overseas colonial possessions of the leading European nations in Africa and Asia, attracted a large number of European and North American scholars, who initiated the study of agricultural sciences in these continents towards the second half of the 19th century. The National Agricultural School of Chapingo, Mexico, founded in 1854, is one of the pioneering agricultural schools of Latin America, together with the National Agricultural Institute and the Superior School of Agronomy (1916), where French scholars played an important role. In the late 19th century, the Agronomic Institutes of Chile and Brazil (Campinas) were founded by European scientists. In Peru, the first “Institute for Agriculture” was conceived by decree in 1869. The “National School of Agriculture and Veterinary” of Peru was inaugurated in 1902 under the direction of the Belgian Agricultural Engineer Georges Vanderghem; 14 Belgian professors from the Agricultural Institute of Gembloux (1901–1913); and six French professors from the Agricultural School of Montpellier. Two Italians, one German, and one North American professor, completed the foreign Staff of the school (Olcese, 2002).

The creation of the Land Grant Colleges (LGC) in the United States (Morril Act of 1862), with the purpose of providing technical support at the state level, had a significant influence in the agricultural research system of Latin America. The University of Viçosa in Brazil, was crafted after the American LGC system, with the help of North American scientists. In Argentina, a Belgian scientist, Lucien

Hauman, initiated the teaching of physiology, genetics, and plant pathology, and many of his students obtained advanced training abroad. The German professor, Karl Fiebrig, taught in Bolivia and Paraguay, and founded the Agricultural School of Asunción, Paraguay, in 1916. The Swiss botanist Henry F. Pittier founded the first Agricultural School of Venezuela in the 1890s, and the North American Charles E. Chardon, of Cornell University, Ithaca, New York, founded the first Faculty of Agronomy in Palmira, Colombia in the early 1900s. The impulse given to agricultural education in Latin America by European and North American scholars, resulted in the first generation of Latin American agricultural scientists and educators at the break of the 20th century. These Latin American scientists were further educated at US universities, such as California, Cornell, and Wisconsin (Morales, 1999).

In Asia, particularly in India and Malaysia, the British made an effort during the end of their colonial period, to educate local people in business, administration, and general sciences. Numerous agricultural universities, and one of the most well-organised national agricultural research systems in the developing world, attest to this historical development. The creation of a communist state in China in the mid-1990s, led to the redistribution of land to approximately 300 million peasants, who were later organised into state-owned “communes”. This system was not very successful, and food shortages in the late 1950s and early 1960s provoked its collapse. China has almost 23% of the world’s population, but only 6% of its arable land. China has now implemented a “socialist capitalism” that has opened up the country to foreign investment and know-how, including modern agricultural production techniques (Mason, 2000).

The British also made significant contributions to agricultural development in colonial Africa. Makerere University, first established in Kampala, Uganda, as a technical school in 1922, became the University of East Africa in 1963. This university offered courses leading to general degrees of the University of London. It became an independent national university in 1970 when the University of East Africa was split into three independent universities: University of Nairobi (Kenya), University of Dar es Salaam (Tanzania), and Makerere University.

THE INTERNATIONAL AGRICULTURAL DEVELOPMENT NETWORK

In 1930, the United States Department of Agriculture (USDA) created the Office of Foreign Relations for Agriculture, with the purpose of creating experimental stations in tropical countries and thus “collaborate with Latin American countries in the development of crops *complementary* to those produced in the United States”. The plan included the training of Latin American agronomists in the United States. In 1942, the Inter-American Institute of Agricultural Sciences (IICA) was created (based in Costa Rica) by the Secretary of Agriculture of the United States, with the purpose of “promoting a more balanced agricultural economy in the Western Hemisphere”. In 1949, the USDA established the Technical Cooperation Office. This office had the capacity to employ up to 120 agricultural

technicians in Latin America. The Act of International Development of 1961 resulted in the creation of the Agency for International Development (AID) to “provide technical assistance in the fields of teaching, human health, housing or agriculture” (Wortman and Cummings, 1978; Dil, 1997).

Since the 1940s, private Foundations, such as the Rockefeller, Ford, and Kellogg, played a key role in the training of agricultural scientists in Latin America. In 1943, the Rockefeller Foundation initiated the first agricultural programme in Mexico, which in time became the most successful agricultural development project in the history of agriculture. Hundreds of Latin American scientists obtained post-graduate training in agricultural sciences thanks to this initiative that also led to the creation of the first National Agricultural Research Institutes (NARIs) in Latin America. The Ford Foundation initiated its assistance for agricultural development in Latin America in 1959, with a view to strengthening Latin American NARIs. The Kellogg Foundation started its programme in Latin America in 1946, with the establishment of the Central American Institute of Nutrition (INCAP) based in Panama, targeting mainly protein deficiencies. In Peru, the Agricultural Mission of the University of North Carolina also made a significant contribution to training and the teaching of agricultural sciences (Dil, 1997; Olcese, 2002).

The Food and Agriculture Organization (FAO) of the United Nations was established in 1945 to fight world hunger. FAO proposes to emphasise cooperation with the private sector, and promotes the use of internet technology to distribute information on food, agriculture, fisheries, forestry, and rural development. However, closer cooperation with the private sector implies greater pressure from organisations such as the World Trade Organization, considering that FAO is the body in charge of enforcing a “code of conduct” for commerce of agricultural products. This pressure is evident in the area of plant quarantine, which has been significantly relaxed to facilitate the free trade of agricultural commodities (FAO, 1999, 2000).

The United States Agency for International Development (USAID) began as a technical assistance programme in 1961. USAID follows the dictates of the Secretary of State and, therefore, its agenda includes “the expansion of democracy and free markets”. Bilateral technical and financial assistance are often directed towards developing countries that are under the sphere of influence of the donor country. However, USAID assistance includes sub-Saharan Africa, Asia and the Near East, Latin America, and Europe-Eurasia. USAID used to have a large technical staff, but now relies on US universities and other US institutions to provide technical support in developing countries (Wortman and Cummings, 1997).

THE PRINCIPLE OF POPULATION

In 1817, Malthus published his “Essay on the Principle of Population”, arguing that the exponential growth of human population would overtake the world’s capacity to produce food; which increases linearly. His predictions seemed to

have become a reality in the 1950s, in countries such as India and Pakistan, had it not been for major advances in agricultural research that allowed the rapid deployment of high-yielding wheat varieties. These improved wheat varieties were the product of over two decades of intensive research initiated in 1943 as a collaborative training and agricultural research programme initiated by the Rockefeller Foundation and the Ministry of Agriculture of Mexico. The improved wheat varieties were the basis of the “Green Revolution” and the seed for the emergence of the International Agricultural Research Centres (IARCs). Had that serious food shortage been handled by the present-day detractors of the “Green Revolution”, millions of poor men, women, and children would have died from hunger at that time. Unfortunately, food shortages continue to kill and disable millions of people in developing countries, while industrialised nations generate food surpluses.

What Malthus did not foresee, even though he witnessed the dawn of the “Industrial Revolution” in the 18th century, was the major technological advances that were to increase agricultural output in industrialised nations above the birth rate. However, the industrial revolution widened the gap between the economies of industrialised and developing countries; and the latter continue to provide the raw materials that industrialised nations need to manufacture products that continuously increase in price, while the value of the traditional agricultural commodities produced by developing nations continues to decrease, often below production costs. Nevertheless, the Malthusian warning remains real in many developing countries where poverty is linked to high population growth rates, as a result of improvements in overall health and sanitation standards. Population growth for 2050 is projected between 8 and 11 billion people (low- and high-fertility scenarios) who represent an average 50% increase from the 2000 census. But more important, most of this growth will take place in developing countries. By 2050, industrialised nations would have about a billion people, and the developing world over 8 billion. This trend will be more noticeable in Africa, the poorest continent of the world. In 1959, the United Nations Expanded Program of Technical Assistance and the Special Fund were created and later merged in 1966 to form the United Nations Development Programme (UNDP), as the financial body dealing with technical assistance in the UN system. FAO staff members have acted as agricultural advisors to UNDP in the past. (UN, 2007)

THE GREEN REVOLUTION

The exponential growth of the human race was nowhere more visible than in Asia, particularly in countries such as India and Pakistan. Yet, food production only increased in a linear manner in these countries, thus, creating the conditions for a famine of catastrophic proportions. Fortunately, a team of international scientists financed by the Rockefeller Foundation, had developed in Mexico high-yielding dwarf wheat varieties that produced four times more grain than

the existing varieties. The deployment of these varieties to India and Pakistan in 1963–1966 averted famine in those countries. By 1970, Pakistan had increased wheat production from 4.6 million to 8.4 million tons, as the new varieties continued to replace the local wheat varieties. By 1971, India was at the point of reaching self-sufficiency in wheat production. This major achievement was recognised with the Nobel Prize in 1970, bestowed upon Norman E. Borlaug, Director of the Wheat Improvement Project in Mexico. In his acceptance speech, Dr. Borlaug said: “I shall not dwell upon the personal honour, for I have not done so even within myself. Instead, I want to devote my remarks to commendation of the Nobel Committee which had the perspicacity and wisdom to recognise the actual and potential contributions of agricultural production to prosperity and peace among the nations and people of the world” (Dil, 1997).

The “Green Revolution” started by Dr. Borlaug, lived on with the release of high-yielding rice and maize varieties created by IRRI in Asia, and CIMMYT in Latin America, respectively. Furthermore, the “Green Revolution” inspired the creation of the CGIAR system and its international agriculture research centres, which have made major contributions to the alleviation of hunger and poverty by improving the world’s major food staples: maize, common bean, cassava, potato, sweet potato, tropical and temperate legume crops, such as cowpea, lentil, chickpea, groundnut, and broad bean. The IARCs have also played a very important role towards assuring food security in the future, by collecting, conserving, and utilising valuable plant genetic resources all over the world.

THE INTERNATIONAL AGRICULTURAL RESEARCH INSTITUTES

The International Rice Research Institute (IRRI), was created in 1960, in Los Baños, Philippines, and soon made a significant contribution to the “Green Revolution” by developing high-yielding rice varieties for Asia. The Rockefeller and Ford Foundations promoted next the creation of the International Maize and Wheat Improvement Centre (CIMMYT) at El Batán, Mexico, in 1967. USAID, UNDP, and the Inter-American Development Bank (IDB) also contributed funds for the establishment of CIMMYT. The initiative to create regional international centres continued and, in 1967, the International Institute for Tropical Agriculture (IITA), was founded at Ibadan, Nigeria. The following year, the International Centre for Tropical Agriculture (CIAT), was established in Palmira, Colombia, to increase the production of various tropical crops and some animal products. The International Potato Centre (CIP) became the third centre in Latin America in 1970.

In 1971, these IARCs were administratively grouped under the Consultative Group on International Agricultural Research (CGIAR or CG for short) with Headquarters in Washington. The CGIAR Secretariat is closely linked to one of the major sources of funding for these centres, the World Bank, and the various donor countries that contribute to the CG system. Technical guidance was initially provided by a Technical Advisory Committee (TAC), which later

evolved into the current Science Council. By the mid-1990s, 13 international agricultural research centres (IARCs) had been established around the world with funding from industrialised nations, Foundations, and international development banks and agencies. The commodity-oriented CG IARCs conducted research on the improvement of important staples in developing countries, and each crop was attended by a multidisciplinary team of specialists at the doctoral or Master's level. Despite the regional distribution of the IARCs, crop mandates were global, with the exception of some commodities, such as rice and cassava, which were shared by different IARCs. A sine qua non condition imposed on the CG IARCs, was that research was to be conducted and transferred through their hosts' national agricultural research system. Training of national staff was a major objective in the beginning of the IARCs, thus, gradually replacing the role of the Foundations and other institutions that financed the training of agricultural professionals from developing countries in the past. However, the training was done on specific crops and not so much with a view to train national professionals at the graduate level. By 1980, very few fellowships were available to undertake postgraduate work in the United States or other industrialised nations (Dil, 1997; IDRC, 1983).

The crop improvement research conducted by the CG IARCs was extremely successful. By 1990, more than 300 wheat and rice varieties had been released to farmers, adding more than US\$50 billion to the value of global food supplies between 1961 and 1981. More than 200 new varieties of maize had been released in over 40 countries. Over 60 new varieties of cassava had been released in Africa and Latin America; and more than 100 new varieties of beans had been adopted by farmers in Latin America and East Africa. (CGIAR, 1994).

THE IMPACT OF MOLECULAR BIOLOGY ON AGRICULTURAL RESEARCH AND DEVELOPMENT

The dawn of Biotechnology had rather humble beginnings in developing countries, basically the adoption and implementation of tissue-culture techniques. The main impact of this technology was initially made in the area of *in vitro* conservation of plant genetic resources. Tissue culture made possible the conservation of land- and time-consuming crops, such as cassava, in reduced laboratory spaces. Other tissue-culture techniques, such as embryo rescue and anther culture, were also regarded as highly promising at the time for crop improvement purposes. Finally, tissue culture was also used to produce pest-free plant germplasm, and facilitate the international exchange of plant genetic resources.

But, perhaps the greatest contribution of tissue culture was to set the stage for the development of advanced molecular biology techniques that eventually led to the genetic transformation of plants (GMOs). The rapid development of several innovative molecular biology techniques, such as PCR, cloning, RAPDs, QTLs, SCARs, further facilitated the characterisation of plant germplasm,

pathogens, pests, etc. These molecular techniques projected human knowledge to unsuspected levels, and were soon matched by equally spectacular advances in computer technology; catapulting biological research to new heights (Persley and Doyle, 2001).

Unfortunately, these breakthroughs eventually proved to be both a blessing and a curse for crop improvement purposes. Many experienced agricultural scientists who had missed the era of molecular biology, were eventually dismissed as part of the downsizing policies implemented in the 1990s at some CG centres, on the grounds of not being “molecular” scientists. Some traditional breeders were forced to either resign or take a crash course in molecular techniques, such as “marker-assisted selection” (MAS), forcing them to spend more time in laboratories than in the field. The widespread belief that molecular markers are able to detect all genes associated with superior agronomic traits in crops (e.g. resistance to biotic and abiotic stresses), accelerated the dismantling of multidisciplinary teams previously entrusted with the responsibility of evaluating plant germplasm. The rapid advances in crop improvement promised by molecular plant breeders have yet to be realised, after more than a decade of highly costly molecular-breeding projects.

Biotechnology has also provided more fuel for environmentalists to attack modern food production technology. In fact, most scientists recognise that the early plant transformation technologies were rather crude and risky. The negative perception of GMOs has not gone away despite notable advances in the area of plant transformation, which render GMOs as safe as any cultivar improved by traditional plant breeding methods (Persley and Doyle, 2001; Pinstrup-Andersen, 2001).

Nevertheless, biotechnology has survived various “pogroms” launched against agricultural sciences in the last decades, because of the considerable potential benefits that this technology holds for humanity at large, not only in the field of agriculture but in the medical sciences as well. However, the generous availability of funds for biotechnological research has also had some additional negative consequences for food production in general. First, most students of biological sciences, are currently trained in molecular biology. This fact would be a positive development if this training did not occur at the expense of basic agricultural sciences (e.g. botany, genetics, pathology, entomology, and physiology). Once students are trained in molecular biology, they can choose to work in any area of the biological sciences, be it mycology, bacteriology, entomology, virology, etc., sometimes without any previous course work in the basic principles of these disciplines. Consequently, their performance as “molecular” mycologists, bacteriologists, entomologists, or virologists, often leaves a lot to be desired, and their ability to solve field problems is usually compromised. This trend continues at most agricultural universities, to the extent that basic courses, such as Plant Pathology, have become “electives” for agronomy graduates. The negative implications of the emphasis on molecular biology training are more apparent in students from developing countries. Once they go abroad to obtain advanced

degrees, they either do not return to their countries, or, if they do, insist on working only in this area, despite the lack of well-equipped biotechnology laboratories in developing countries, and the high costs associated with these technologies.

THE COLLAPSE OF NATIONAL AND INTERNATIONAL AGRICULTURAL RESEARCH

The world recently witnessed the price of oil climb to unthinkable levels in response to acts of war, terrorism, and natural disasters, and lately, the increasing demand of fuel from emerging Asian economies. As the cost of producing manufactured and agricultural products goes up, the negative impact of speculative oil prices on developing countries becomes increasingly apparent.

The oil crisis of 1973 sent shock waves throughout the entire financial system of the world, affecting the economies of both developed and developing nations. Support for agricultural research was one of the first victims of that economic crisis, starting with the agricultural research institutions of the industrialised nations. Suddenly, agricultural scientists were laid off in Europe, and their research institutions were “downsized”. US universities, particularly those belonging to the Land Grant System, saw their funds diminish in significant proportions. However, this economic crisis did not seem to affect developing regions, such as Latin America, until the late 1980s. The delayed effect of the economic oil crisis of the 1970s, was related to the exorbitant sums of money made by the Arab oil-producing countries, which eventually found their way into the major banks of the western hemisphere. As a consequence, banks had an unexpected surplus of deposits that had to be put to work. The main victim of the readily available, high-interest (6–20%) loans was Latin America, unfortunately, at a time when this region was beginning to experience a positive economic growth. As a result of the onerous loans contracted, the external debt of Latin America climbed rapidly from US\$45 billion in 1973 to US\$481 billion in 1993 (Roddick, 1989).

In order to make sure that Latin American countries paid their suffocating and ever-increasing debt, the World Bank and its executing arm, the International Monetary Fund (IMF), imposed strict austerity measures throughout Latin America, to curtail “public spending”. Unfortunately, this fiscal item includes basic infrastructure, health services, education, and *agricultural research*. Consequently, in the late 1980s and 1990s, most NARIs in Latin America suffered a severe process of downsizing that resulted in the departure or early retirement of most of the experienced agricultural scientists; the closing of many research programmes; and the gradual deterioration of their material infrastructure. This situation, which also affected Africa, persists to date, with the exception of countries such as Brazil, China, and India, the emerging economies of the world.

Even though the CG system's core budget only grew modestly in the 1980s, from US\$143.8 to US\$173.2 million, it had to witness the gradual deterioration of the entire agricultural research network it had created in their target countries. This crisis rapidly reached the CG centres in the period 1989–1994, reducing core funding by more than 20% (O.D.I., 1994; CGIAR, 1996). The impact of these cuts amounted to a reduction of an average 30% in commodity-oriented research, and the departure of up to 25% of the scientific and support personnel in some IARCs. By 1996, the situation had worsened and the operational budget and staff of some IARCs was reduced again by 50%.

Surprisingly, amidst this economic crisis, the CG system managed to increase the number of member centres to 16 in the 1990s, and some centres actually increased the number of projects, in hopes of counteracting a phenomenon that they interpreted as “donor fatigue” and even “donor dissatisfaction”. This decision was also taken in response to the creation of the UN Fund for the Environment, perceived as a new strategy to fund research on natural resource management, in response to the “failure” of the CG centres to address the negative impact of the “green revolution” on the environment. In fact, attention to environmental issues was unequivocally paid by some of the CG IARCs and their commodity programmes prior to the financial crisis of the 1980s. For instance, in 1984, the Director General of CIAT, Dr. John L. Nickel, delivered a lecture at the State University of New Jersey, entitled: “Low-input, environmentally sensitive technologies for agriculture” (Nickel, 1987).

The centre and programme diversification of the CG System has not been a fortunate strategy, as the CG's core contributions continue to fall year after year. It has simply become a redistribution of limited resources among a scattered group of actors and activities. This fact confirms the presumption that the main factor responsible for the CG crisis was purely economic in nature. Unfortunately, the continuing loss of core funding has undermined the capability of both NARIs and IARCs to generate improved germplasm for resource-poor farmers, because this is a long-term undertaking that cannot be done with dwindling and erratic funding. In the absence of improved cultivars that do not require high inputs, mainly pesticides, small-scale farmers have not been able to improve their livelihoods. Their most basic need, access to improved varieties, is simply not available anymore. In the mean time, old cultivars demand an increasing amount of pesticides and fertilisers, as new pathogens and pests attack traditional crops.

THE GREEN COUNTER-REVOLUTION

The “Green Movement” was born in 1972 in New Zealand; and then gained political status in Germany. The first World Conference on environmental issues, held in Stockholm, in 1972, led to the creation of the Environmental Programme of the United Nations. In 1987, the Brundtland Commission published their report “Our Common Future”, where the term “sustainable” appeared for the first

time. However, this report did not share the radical views of the “Green Party”, but, rather, advocated a “sustainable development” approach. In 1991, a special fund was created for environmental studies with support from the World Bank, the United Nations Development Programme, and the UN Environmental Programme. This development prompted the incorporation of more IARCs to the CG System, specifically IARCs that were already working in the area of natural resource management:: agroforestry, aquatic resources, and forest management. The famous Rio Conference convened by the United Nations in 1992, with the participation of over 30,000 people of 170 countries, changed the agricultural research agenda of industrialised and developing nations until today (Conway, 1998; Cordeiro, 1995).

Once in power, the Green Party members and followers in the western hemisphere influenced their international development agencies to preferentially fund projects in the area of natural resource management. National and international institutions in developing countries reacted rapidly to the new research agenda of the donor agencies. Natural resource management projects (NRMP) dealing with forestry, hillsides, water conservation, the Amazon, etc. were created overnight throughout the agricultural community. Unfortunately, the new projects required new staff, mainly social scientists, that had to be hired at the expense of the already downsized crop improvement programmes. Moreover, the new NRMPs were launched as independent ventures (from the commodity programmes) to escape the perceived stigma of crop production/improvement programmes. As a result, two highly complementary areas of agricultural research were maintained separately, instead of joining efforts to promote environmentally friendly and sustainable food production systems.

Whereas modern crop production has certainly contributed to environmental contamination, due to heavy reliance on various agrochemicals, applying pressure on governments to cut funding for crop production research, ignored the day-to-day reality of millions of poor farmers whose livelihoods depend on technical assistance on matters related to crop improvement and crop production. And it is precisely the disarticulation and downsizing of crop production programmes at NARIs and IARCs, which is the reason why farmers had to fend for themselves without technical assistance or new improved varieties. As crop production problems increased for most farmers in the 1990s, the gap left by the crop production scientists was rapidly filled by the agro-chemical companies that could thus increase the sale of their products to combat the biotic and abiotic problems that constantly evolve to affect crop production around the world. Crop failure for lack of technical assistance to small-scale farmers has also had an even more tragic consequence: the cultivation of illegal crops, such as coca and poppy, in poor rural areas of developing countries. These crops attract considerable violence and widespread aerial eradication campaigns using herbicides. Thus, the “environmentalists” and their crusade have actually contributed to a significant increase in the use of agrochemicals

and their noxious effects on the environment and human health, particularly in resource-poor rural regions.

The much reduced crop improvement work at NARIs and IARCs in developing countries, negates the right these countries have over the utilisation of their plant genetic resources, and forces resource-poor farmers to practise slash-and-burn agriculture in marginal lands to compensate for their low productivity. This is yet another example of the negative impact that the radical “environmental” movement has inadvertently caused by putting pressure on international development agencies to divert financial aid away from crop production projects. Ironically, the replacement of crop production specialists by social scientists, has not solved the main cause of these socio-economic and ecological problems: the difficulty that resource-poor farmers have to grow crops in order to feed their families and generate additional income to meet their most elementary needs (e.g. health, education). Farmers cannot “farm” if they do not have a suitable cultivar that they can grow at a profit. Most of the current social projects designed to improve farmers’ livelihoods, blatantly ignore a basic premise: if crop production is not profitable, viable, or sustainable, there is no escape for farmers from hunger and poverty in developing countries. To correct the current waste of farmers’ time and precious resources, crop production and social scientists must be integrated into a coherent project with a common objective: to help farmers implement sustainable and profitable crop production systems within their limited resources.

THE “PROJECTISATION” OF AGRICULTURAL RESEARCH

The original concept of an agricultural research “programme” was a well-structured and multidisciplinary group of scientists working together towards a common and clear objective. When the first IARCs were created, the main objective was to “put food on the table of the rural and urban poor”, as it was originally stated in blunt terms. The original commodity programmes at IARCs used to include: a coordinator, pathologist, virologist, entomologist, microbiologist, physiologist, soil scientist, agronomist, economist, and one to three breeders. These inter-disciplinary teams were referred to by the Nobel Award winner, Norman Borlaug, as one of the main accomplishments of the CG system. The economic crisis of the 1970s and pressure from environmentalist movements brought about the disintegration of these international commodity programmes and multidisciplinary teams. Surviving scientists were asked to find their own research money and even their salaries from special projects financed by donors willing to support short-term research. The performance and continuity of agricultural scientists began to be evaluated according to the amount of funds obtained from external sources; rather than on their contribution to the development of superior germplasm and its adoption by resource-poor farmers.

Once scientists began to be evaluated according to the number of special projects granted and the amount of funds obtained from these external projects,

the “team spirit” gradually disappeared. Successful scientists were given considerable freedom to accept projects that may have never been part of the original research agenda. Once a scientist secured enough operational funds, he or she could work quite independently. Thus, the responsibility of searching for operational funds, shifted from administrators to scientists, who soon found themselves doing both jobs; securing the funds and executing the work. Obviously, this new system greatly decreased the productivity of scientists, who soon found themselves spending a considerable amount of time making contacts, writing project proposals, and, if they were successful, writing technical progress and annual reports for both the donors and their own institutions.

To date, a myriad of 1- to 3-year projects have been conducted in developing countries to address an equally large number of dissimilar research topics. These proposals seldom provide scientists with sums above US\$30,000/yr, and US\$2,000/yr projects are not uncommon in this current maelstrom of “special” projects. Out of these funds, scientists have to pay from 15–35% in administration (overhead) costs. To further diminish the purchasing capacity of these limited funds available, the high security costs imposed by the United States on the transportation of ‘dangerous’ chemical and biological products, has tripled the price of importing the research materials that developing countries must acquire in industrialised nations. In many developing countries, governments have created their own official entities to finance special agricultural research projects on a purely competitive basis. Thus, universities, NARIs, NGOs, IARCs, and even the private sector may apply for the limited funds available, most of which come from international loans that developing countries have to pay back.

The “projectisation” of research may give some donors the feeling that their money is being spent in a transparent and accountable way, but “donor-driven research” has been responsible for the disintegration of the highly productive and effective multidisciplinary teams that used to produce the improved cultivars that small-scale farmers require to produce food and income for their rural households. Spending US\$50,000 to identify the causal agent of a phytosanitary problem, or \$150,000 to detect a gene, will not make any significant contribution to crop improvement if the rest of the biotic and abiotic problems that affect crops are not simultaneously addressed and incorporated into a comprehensive crop improvement programme. In the early stages of their history, the CG centres were highly transparent, accountable, and productive given their relatively low operational budgets. The “projectisation” of international agricultural research has actually increased the total funds currently spent by most CG centres, and, yet, their economic situation constantly borders bankruptcy because IARCs end up subsidising most special projects. More important, the contribution of these disbursed, short-term special projects to the alleviation of hunger and poverty is practically nil, due to the different interests of donors and lack of coordination among projects at all levels of their implementation.

Consequently, some of the most productive IARCs have reached a state of bankruptcy due to this ill-conceived system and the unrealised expectations

placed on highly unproductive projects in the area of natural resource management and social studies, at the expense of crop improvement projects. As a result, the World Bank (connected to the CG IARCs through its Secretariat) had to intervene to save the CG IARCs through different schemes ranging from complementary funds (to the amount of external funds obtained); basic performance indicators (e.g. number of publications, conferences attended, number of trainees), and “challenge programmes” (CPs). A CGIAR-CP is “a time-bound, independently-governed program of high-impact research, that targets the CGIAR goals in relation to complex issues of overwhelming global and/or regional significance, and requires partnerships among a wide range of institutions in order to deliver its products”. In 2001, the CGIAR decided to implement three “pilot” CPs: (1) the “Generation” CP, which “uses advances in molecular biology, and harnesses the rich global stocks of plant genetic resources to create and provide a new generation of plants that meet farmers’ needs”, (2) the “Harvest Plus” CP, which “seeks to reduce micronutrient malnutrition by harnessing the powers of agriculture and nutrition to breed nutrient dense staple foods”; and (3) the “Water and Food” CP to “create research-based knowledge and methods to grow more food with less water” (www.cgiar.org/impact/challenge). Unfortunately, it is quite evident that the use of advanced molecular techniques has not shown so far to “meet farmers’ needs” and, in the absence of improved cultivars possessing desirable agronomic/commercial characteristics, farmers cannot profit from “nutrient-dense” breeding lines. Regarding the need “to grow more food with less water”, “drip irrigation” was already being used almost a century ago, and many resource-poor farmers have already adopted this practice. In the mean time, the main crop production problems that affect small-scale farmers all over the world remain a major obstacle to meeting the most basic food production needs in rural areas of the developing world. As to the goal of fostering “partnerships among a wide range of institutions in order to deliver products”, it is difficult for institutions suffering a continuous erosion of their operational budgets, particularly due to the deviation of funds from their core budgets to finance special projects (including the CPs), not to view these undertakings as yet another series of “competitive projects”.

THE GLOBALISATION OF THE ECONOMY

The spectacular progress and lower costs achieved in the area of information and communication technologies, has brought the nations of the world closer and facilitated international trade. In view of these developments, the industrialised countries of the world have been advocating the elimination of artificial barriers to free trade, such as tariffs and subsidies, that protect the limited industrial and agricultural capacity of developing countries, while continuing to protect their own industrial and agricultural sector with the same measures. Nevertheless, multilateral trade liberalisation embodied in the General Agreement on Tariffs and Trade (GATT), has been making rapid progress (Stiglitz, 2002). In fact,

70% of the 134 members of the World Trade Organization (WTO) in 1999, were developing countries.

It is a well-known fact that “protectionism” often leads to the perpetuation of inefficient, outdated, low-quality and costly production systems in developing countries. However, it is also very clear that the poor nations of the world cannot compete with the industrial or agricultural sectors of North America or Europe, even in the absence of subsidies. In North America, less than 5% of the population is engaged in agriculture, and, yet, they produce enough food to meet the internal demand, and generate significant food surpluses for export. The high productivity of the North American and European farmers is closely associated with the technological and industrial development of their countries. On the contrary, the majority of the world’s poor live in rural areas of developing countries, and depend on agriculture for their food security and income. Thus, most developing countries remain net producers of natural resources that fuel the industrial production of developed nations; and are avid importers of manufactured goods, such as agricultural machinery, fertilisers, and agrochemicals.

The main problem of “free trade agreements” is that the “terms of commercial exchange” between developed and developing economies have greatly deteriorated in the last five decades. That is, developing countries receive less money for their natural resources, but have to pay higher prices for the manufactured products they import from the industrialised nations (Stiglitz, 2002).

The fact is that all countries must export and import products according to their absolute, comparative, and competitive advantage. Developing countries often rely on their absolute advantages to produce and export their natural resources and agricultural products: minerals, cotton, sugar, coffee, etc. The quantity produced and price of natural resources depends on the interaction between supply and demand, but there are other production factors (land, capital, labour, technology) that determine the cost of production in developing countries. In developing countries, land (rent) is relatively cheap, but scarce for resource-poor farmers, who lack the resources to acquire more land or inputs (e.g. fertilisers) to produce more food in limited areas. On the positive side, small-scale farmers in developing countries, use a significant amount of family labour, or have relatively lower labour costs. But these “comparative advantages” are offset by the lack of a more important production factor, often neglected in developing countries: **technology**. For instance, whereas an American farmer in Michigan can produce 2,000 kg of common beans per hectare, a small-scale farmer in Central America produces on average 700 kg/ha. Ultimately, the so-called “comparative advantage” of developing countries, understood as “the production of goods at the lowest price possible”, is not realised when compared to industrialised nations for which “comparative advantage” means the production of goods that generate the highest profit, regardless of their cost of production. Thus, developing countries, such as Colombia, produce coffee at a

cost of US\$1.00/lb, but despite the relatively low labour costs in this country, coffee prices in 2006 dropped to US\$0.75/lb in the international market.

The dwindling price of most agricultural commodities produced by developing countries, has been steadily falling since the 1950s, due to the manipulation of markets by the large multinational companies of the industrialised countries. Some of these big companies have the power to dissolve commercial agreements that promote the so-called “Fair Trade”, as it happened in 1989, when coffee prices were fixed at US\$1.30, thanks to an international coffee pact that set quotas for all coffee-producing countries. Not content with this agreement, the few multinationals that dominate the coffee business in the industrialised world, convinced the smaller producers of coffee in the world to support their petition to end the international coffee pact, by promising an increase in their coffee export quotas as soon as the pact was abolished. Once the international coffee agreement was terminated, the price of coffee dropped to US\$0.60, thus, creating a major economic crisis for millions of small coffee growers around the world, including the developing countries that supported the petition to terminate the agreement. However, the European or American consumers never benefited from this drastic reduction in coffee prices, even though the multinational companies that instigated this crisis, made over US\$12 billion dollars’ profit in the first year following the termination of the coffee pact. Not content with these unfair practices, these multinationals have been promoting the cultivation of poor-quality (robusta) coffee in Asian countries, such as Vietnam, where labour wages are even lower than in Latin America, to bring the price of coffee to US\$0.30/lb. In the mean time, a cup of coffee sells for over US\$2.00 in any European or US city. The coffee-producing countries were also legally forbidden to add value to coffee (e.g. producing instant, decaf, or any other specialty coffees), which was the prerogative of the foreign companies that bought the unprocessed coffee beans. Whereas this situation has somewhat changed in the recent past, the “competitive advantage” given by technological advances and a recognised label in the coffee business, remains with the multinationals. In the end, the average gross domestic product (GDP) of the 20 richest nations was 15 times greater than in the 20 poorest nations in 1960. Thirty years later, this difference between the rich and poor nations doubled (World Bank, 2000).

CURRENT SITUATION AND OUTLOOK

The removal of agricultural trade barriers would be a desirable outcome of any free-trade agreement, if industrialised nations removed their own protectionist measures, instead of asking developing countries to remove theirs, unilaterally. Another hidden face of protectionism includes the increasingly restrictive measures to the movement of citizens from developing countries into the United States and the European Community. At present, most developing countries are under pressure to sign free-trade agreements with industrialised nations,

but even the boldest governments in the developing world, are understandably trying to protect their modest agricultural and industrial sectors.

There is no doubt that some developing countries could manage to maintain their absolute, comparative, and/or competitive advantages in the case of some traditional export crops, such as coffee, banana, sugarcane, and cotton (particularly if the cost of imported inputs is reduced through a free-trade agreement). However, developing nations will continue to be marginalised from the non-traditional export crop market, as long as they do not generate and provide technical assistance to their farmers, particularly in the case of high-value crops, such as fruits and vegetables, for which some countries in Latin America show a positive commercial advantage to compete in an open market (Hertford and Garcia, 1999). Developing countries would also have to provide the necessary market intelligence to manage these highly unstable agricultural markets. Undoubtedly, some farmers and farming systems in developing countries will be negatively affected under free-trade agreements, and these may very well be the food staples produced for the internal markets. Subsistence farmers that produce crops, such as maize, rice, beans, and potatoes, usually have little access to markets, and derive over 50% of their income from non-agricultural sources (CEPAL, 2001). On the other hand, the urban poor would be expected to benefit from lower food prices. Another big potential player in the market of food staples is China. We have already seen its capacity to export staples, such as common bean to Latin America. This and other socialist economies characterised by low agricultural wages are also a threat to developing economies with higher labour costs.

The role of IARCs in a globalised economy

Assuming that developing countries will eventually open their economies and remove trade barriers, the issues of food security and competitiveness will become extremely important. Whereas IARCs were originally created to address the issue of food security (the equivalent of subsistence agriculture), there is no reason why these centres cannot help farmers become competitive with their basic food crops in an open-market situation. To this end, small-scale farmers would require improved cultivars and technical assistance to increase average yields to at least 50% of the crop production averages currently obtained in developed countries. This is a modest goal, by no means impossible, if the CG System and its donors understood that the first step in the war against hunger and poverty is to be able to produce food and/or industrial crops in a sustainable and profitable manner. The CG centres were created to make this possible, not to become centres of excellence in social sciences, biotechnology, promote eco-tourism, save the Amazon, or fight battles against emerging diseases. There are more capable and specialised institutions addressing those problems.

The CG centres can also evolve to take a more comprehensive look at the diversified cropping systems that small-scale farmers have been unsuccessfully

trying to implement for the last three decades. These mixed cropping systems are basically a portfolio of: (1) major food crops, such as maize, beans, and potatoes; (2) cash crops, such as sorghum, cucurbits, and peanut; and (3) high-value crops, such as tomato, peppers, and many other horticultural crops. CG centres can approach these cropping systems in alliances with NARIs or other IARCs, from a regional point of view (e.g. the highlands, mesothermic valleys, or tropical lowlands; or according to their primary mandate (e.g. legumes, solanaceous crops). This approach would assure food security and help small-scale farmers maximise the profitability of their limited land resources, in order to minimise risk and improve their livelihoods. Multi-farm systems can “improve the efficiency of the use of the land in both time and space, while increasing the ability to preserve the environment” (CIAT, 1994). Free trade also has a very important requirement often disregarded by developing countries that believe that any product can be exported; the high quality demanded by consumers in industrialised societies. Undersized, blemished, pest-ridden, or highly contaminated (pesticide abuse) produce is not allowed to enter the food markets of developed countries. International agricultural R&D institutions can also play a major role in this critical area of food production and marketing in developing countries.

The role of donors in the renovation of the CG system

On the question of the financial requirements for the CG IARCs to regain its mission and capacity to contribute to the alleviation of hunger and poverty, there are various considerations. First, foreign aid is still largely determined by the historical relationship between the industrialised nations and their past colonies or current regions of influence (e.g. Europe finances R&D particularly in Africa, Japan in Asia, and Australia in the Pacific region.). Second, industrialised nations have democratic governments that are elected by diverse groups of supporters, including farmers’ associations. These groups have enough political clout to lobby for protection of their economic interests. Third, agricultural R&D requires a sustained effort to achieve its goals. The CG system cannot continue to stop and change directions every time a new “school of thought” comes along (e.g. natural resource management, land use, farmer participatory research, rural innovation, and challenge programmes). Innovation is an important factor in human evolution, but it should not require a clean break with past activities. If the world had to go back to the starting point every time a new development or technology came along, we would still be in the Stone Age. New components can be incorporated into a well-conceived, sustainable crop improvement programme, without bringing ongoing research to a halt. The “projectisation” of research and “donor-driven” research must come to an end as the main causes for the collapse of the CG System, and its incapacity to remain a major player in the R&D arena. The creation of a portfolio of attractive projects financed by a “loosely organised association of donors”, rather than

restructuring a centre based on carefully analysed research priorities, has been a major managerial mistake (Reece, 1996).

Poverty and hunger should not be alleviated according to the historical or commercial relationships between a donor country and an ex-colony or market, because this policy only perpetuates the “economic imperialism and dependency” discussed above. In the past, the donor community pledged their contributions to the CG System and other IARCs involved in international R&D; and an able body of administrators allocated the funds according to the dimension of the task entrusted to each IARC. The World Bank acted as a financial buffer to make sure that the research priorities identified by the Technical Advisory Committee were addressed by centres that did not obtain the necessary financing from the international donor community. The current emergence of populist and leftist governments in Latin America is a reflection of a region that has been exploited by foreign economies and yet, neglected by the international donor community in past decades. The illegal drug trade and violence (guerrilla warfare) generated by drug trafficking is another consequence of the long-term neglect of poor farming communities in Latin America. Furthermore, important food crops in Africa, such as cassava, sweet potato, bananas, and many vegetables, originated in other regions of the world, where the genetic variability and other important resources, such as biocontrol agents, exist. Allocating most of the R&D funds to a single region, affects the conservation and improvement of valuable genetic resources and technology in the regions of origin of major food crops.

The fact is that the original purpose of the creation of the CG IARCs has not changed. About 800 million people do not have access to enough food to live a healthy life. 520 million of these people live in Asia; 180 million live in sub-Saharan Africa, and about 90 million are in the rural areas of Latin America (Pinstrup-Andersen et al., 2001). If farmers cannot produce crops efficiently to meet their food requirements and generate income to improve their livelihoods, it is irrelevant to talk about “sustainable agriculture”. This premise becomes even more critical in view of the current trend to eliminate subsidies and other protection mechanisms for agricultural products in developing countries. Under a free market system, even small-scale farmers will have to be highly competitive (produce high-quality goods at a low price) to survive and prosper. The organisation of farmers into cooperatives; the integration of farmers into the market, and the implementation of sustainable agricultural systems are highly relevant issues that need to be addressed in an interdisciplinary manner where both crop production specialists and social scientists work together as a team. To expect IARCs to become fully funded and financially stable from a limited number of competitive special projects, while remaining at the service of the poor, is a utopia conceived by a donor community that does not want to make a serious commitment to the alleviation of poverty and hunger. The continuous need for IARCs to survive on restricted project funds, particularly projects of purely social or natural resource management nature, has caused some IARCs to leave the financing

of their crop improvement projects in the hands of the industrial sector that only caters to the interests of wealthy, large-scale farmers.

Main barriers to agricultural development

The main constraint to achieving social development in the rural sector of developing nations is the lack of investment in agricultural research. Whereas low-income countries spent less than a dollar per capita in the 1990s, industrialised nations spend almost US\$9 per capita in agricultural research (Pardey et al., 1991). Unfortunately, many developing countries fell in the trap of the external debt that only benefits foreign banks and investors from industrialised nations. The International Monetary Fund (IMF) has been making sure that developing countries pay their debts by applying drastic, shock measures that have driven many emerging and even well-founded economies into bankruptcy; Argentina being a good example of the latter. One of the main demands made by the IMF upon debtor countries, has been a drastic reduction of public spending (the antithesis of Keynesian economics for countries suffering from unemployment and economic recession). Besides public health, “public spending” includes education and agricultural research. Without economic growth, education, or generation of technology, developing countries will never be in a competitive position with respect to industrialised nations. Moreover, the restrictive measures imposed by the IMF on developing countries caught in the trap of the external debt, create recession and unemployment. The lack of employment (income) is obviously one of the main causes of famine and malnutrition in urban and rural households of developing countries (Ford et al. 2003).

The lack of investment in “productive” agricultural R&D in developing countries by foreign aid agencies/departments, has further contributed to set back the significant progress made by NARIs and IARCs up to the 1980s. Millions of dollars in contributions to IARCs have been invested in the last two decades in social studies that address semantic and conceptual issues, totally irrelevant to poor farmers in the absence of improved cultivars and technology that allows them to produce food and income for their families, in order to meet their most basic needs. New R&D terminology, administrative charts, performance indicators, programmes, projects, and recently, “products”, are created every day without any regard for the real needs of resource-poor farming communities: improved food crops they can grow with minimum risk and environmental impact; maximum yields and profit.

The reorganisation of agricultural research in developing countries

Governments and their Ministries of Agriculture in developing countries need to understand that well-staffed, well-equipped, and well-financed NARIs are essential for the agricultural sector to be able to compete in an open market environment. Without technology, crop production costs and yield losses will remain

too high to compete with either industrialised countries (high productivity) or developing economies with low land/labour costs. In order to achieve an effective reorganisation with the limited financial resources available, agricultural research needs to be initially centralised into research facilities representing all the disciplines involved in agricultural R&D. The emphasis should be on solving the main crop production problems as defined by farmers' associations, growers' federations, the industrial sector involved in agriculture, agricultural marketing specialists, and the agro-exporting sector. Thus, governments in developing countries must understand that subsidising agricultural products (as developed nations do), only preserves their inefficient agricultural systems, instead of investing in agricultural technology and extension to increase their agricultural productivity and lower the dependency of farmers on subsidies and other artificial and costly market protection practices bound to be eliminated under a free-trade agreement.

Financing viable agricultural projects should be the responsibility of both the public and private sectors, depending on research priorities and socio-economic considerations. In some developing countries, the private sector has either created its own research branch or contracts research outside the country. None of these alternatives has proven viable because crop production problems require thorough knowledge of the crop, the environment, and the discipline related to the problem; plus time, and adequate human and material resources. Usually, the private sector has the agronomic knowledge of crops, but agronomists cannot solve many complex production problems, such as emerging pests and diseases because they have neither the training nor the necessary equipment to diagnose exotic crop production problems. These recommendations would only cost a fraction of the economic losses suffered by the agricultural sector in the absence of technical know-how and permanent assistance to farmers.

Strengthening the agricultural research capabilities of a given developing nation would not necessarily contribute to improving the livelihood of many small-scale farmers who are not integrated into the existing markets. But, once a strong agricultural research institution is in place, small-scale farmers would have a better chance to have access to improved varieties, technical information, and new markets. Small-scale farmers have some important comparative advantages, such as the use of family labour, which has shown to be attractive for some producers of high-value, labour-intensive export crops.

A brighter future?

Human Health is another emerging issue in the CG system, including malnutrition, infant mortality, the spread of AIDS, and pesticide contamination in tropical countries. The Harvest Plus (bio-fortification) Challenge Program was particularly designed to address these issues, with financial support from the Bill & Melinda Gates Foundation. Whereas this is undoubtedly a worthwhile undertaking, it is based on the assumption that crop production in the

tropics has no other problems, and that we can proceed to replace the main cultivars of several food crops with “nutrient-dense” varieties. Unfortunately, to cite just one case, improving common beans for their iron content (which they already have a significant amount of), does not solve the current pest, disease, and agronomic problems that prevent farmers from growing common bean in many regions of the world. The development of golden rice, high-quality maize, orange-fleshed sweet potatoes, and other vitamin-A-rich crops, does not necessarily require the creation of genetically modified crops or new varieties, because many of these selected crops, as in the case of common bean, are naturally rich in some nutrients or have specific genotypes that can provide these traits through traditional plant-breeding schemes. However, all of these commodities need constant improvement to counteract the evolution of diseases and pests, and environmental changes that these crops face as there are pushed by industrial development and urbanisation into marginal lands. CG IARCs rapidly embraced these new initiatives in order to survive, but their current crop improvement capacity has been so drastically reduced that the development of agronomically desirable varieties possessing additional nutritional qualities, becomes a chimera.

It seems that the Gates Foundation has realised the futility of continuing to fund special projects disconnected from the complex reality of tropical agriculture, and has now announced a collaborative venture with the Rockefeller Foundation to rescue the CG System from its long-standing financial and managerial crisis, in order to bring food once more to the table of the rural and urban poor, through the generation of relevant agricultural technology and implementation of environmentally friendly crop production strategies.

CONCLUSION

Agriculture is the science of cultivating plants. It took thousands of years to domesticate plants in order to make them more productive and, thus, feed a growing human population. Our ancestors selected wild species until they developed higher-yielding varieties of all of the main food crops consumed in the world today. But those primitive farmers also understood that selecting plants was not enough; and they developed agricultural technologies to further increase yields; water management and fertilisation, for instance. Human intervention in the natural process of plant evolution necessarily causes concomitant changes in the evolution of those organisms that interact with plants or depend on plants to fulfil their biological needs. This is the origin of the new pests that constantly emerge in order to adapt to new cultivars all over the world. Agro-ecosystems also change due to natural (e.g. global warming) or artificial causes (e.g. irrigation districts, mixed cropping systems). Thus, crop improvement is a never-ending task that requires continuous attention by specialists dedicated to the study of the main biotic and abiotic constraints that affect food production. Equally important, in order to produce food, humans must have

access to the elementary production factors: land, labour, capital, and technology. Land is a scarce and fragile production factor that must be protected and maintained in order to develop sustainable cropping systems.

Agricultural scientists must be able to generate superior germplasm and technology to allow resource-poor farmers to produce enough food and farm income, to satisfy their basic needs and improve their livelihoods without damaging the environment or their own health. If farmers cannot produce food because of crop production problems or high production costs, all other considerations would become secondary. Environmentalists have to realise that, in the absence of technical assistance, farmers will continue to contaminate the environment and poison both their households and urban consumers with the pesticides used to protect their crops.

Social projects can help protect the environment, organise farmers, set up agro-enterprises, conduct farmer participatory activities, but if there is not a viable and profitable food production component in these activities, farmers will remain in a state of chronic misery. This is basically the situation we are contemplating since most NARIs and IARCs in developing countries were “downsized”, and turned into opportunistic, dysfunctional institutions that do not solve the most elementary food or crop production problems that have made hunger and poverty endemic scourges in developing nations.

Agricultural R&D policies and management should be dictated and conducted by scientists who are familiar with the biotic, abiotic, and socio-economic constraints of crop production in developing countries. Historical and political issues or lobbying from pressure groups should not interfere with the mission of producing more and healthier food for the poor, rural, and urban sectors of the world in a sustainable way. We have the necessary technology to produce food with minimal environmental impact, and still generate income for resource-poor farmers. If the international community is seriously committed to the alleviation of hunger and poverty for over 800 million people living in poverty, it has to put an end to the current donor-driven research policies responsible for the lack of coordination, clear mission, and accountability of the CG System. Wasting public funds on academic social issues, or addressing purely environmental issues in the presence of millions of people suffering from hunger, malnutrition, and disease, is a crime against humanity.

Managing international agricultural R&D institutions in the current unstable and ever-changing environment is a very challenging task. In the past, Directors General and Directors of Research had a stable budget that allowed them to pursue a clear and viable mission. Today, the donor community is divided among different R&D strategies and, consequently, funding is allocated in an unpredictable and competitive way. Consequently, research managers must constantly keep changing their research agendas and priorities to accommodate new projects and research strategies, in order to cope with the continuous erosion of their core funds. As the global economic situation worsens due to wars, climbing oil prices, social unrest, and a developed world hungry for illegal drugs, so does

the financial situation of the IARCs that have demonstrated their capacity to increase food production in the Third World.

The parallel collapse of the national agricultural research system in developing countries, further diminishes the probability of making even a partial contribution to the UN Millennium Development Goals aiming at halving poverty in the world by 2015, considering that most of the poor people in developing countries live in rural areas heavily dependent on agricultural R&D. The international agricultural research community needs strong leadership from individuals committed to the mission of fighting poverty and hunger and, more important, capable of convincing donors that their contributions have to be administered by an able body of agricultural scientists-administrators. The current crisis of the IARCs is only a reflection of the current failure of the CG and other international R&D systems to demonstrate to the international donor community that their current funding practices are the main cause for the lack of impact of IARCs in their struggle against hunger, poverty, and disease in developing nations.

As one of the Director Generals of the International Food Policy Research Institute, Joachim von Braun, was quoted: “No one can pretend that ending hunger will be easy, but it *must* and *can* be done” (Ford et al., 2003). In the same publication, the terrorist attacks to one of the most prominent symbols of capitalism in the world, prompted the authors to mention “global peace and stability can only be achieved by ending the deprivation of the world’s poor”. It is up to administrators, scientists, and donors involved in agricultural R&D, to decide in what kind of world we would like to live.

REFERENCES

- CEPAL. 2001. *Desarrollo rural en América Latina y el Caribe*. Alfaomega Editores, Bogotá, Colombia.
- CIAT. 1994. *Hillsides Programme. Annual Report 1993–1994*, Palmira, Colombia.
- CGIAR. 1994. *Challenging Hunger: The Role of the CGIAR*. Pragati Printers, Hyderabad, India.
- CGIAR. 1996. *Annual Report 1995–1996*. CGIAR, Washington, DC.
- Colombian Ministry of Agriculture. 2001. *Agrovisión Colombia 2025*. Presidencia de la República, Bogotá, Colombia.
- Conway, G. 1998. *The Doubly Green Revolution*. Cornell University Press, Ithaca, NY.
- Cordeiro, J.L. 1995. *The Latin American Challenge*. McGraw-Hill, NY.
- Dil, A. 1997. *Norman Borlaug on World Hunger*. Pakistan International Printers, Lahore, Pakistan.
- FAO. 1999. *The Strategic Framework for FAO: 2000–2015*. FAO, Rome.
- Ford, C., Senauer, B., Pardey, P.G., and Rosegrant, M.W. 2003. *Ending Hunger in Our Life Time: Food Security and Globalisation*. Johns Hopkins University Press, Baltimore, MD.
- Goldammer, J.G., and Seibert, B. 1989. Natural rainforest fires in Eastern Borneo during the Pleistocene and Holocene. *Naturwissenschaften* 74: 518–520.
- Halperin, T. 1990. *Historia Contemporanea de America Latina*. Editorial Alianza, Madrid, Spain.
- Harris, J.E. 1972. *Africans and Their History*. New American Library Press, NY.
- Hertford, R., and Garcia, J.A. 1999. *Competitividad de la Agricultura en las Américas*. CIAT, Palmira, Colombia.
- Hudson, K. 2002. Wires cross over genes. www.ancestrybydna.com/articles04.html

- Kreis, S. 2006. Charlemagne and the Carolingian Renaissance. www.historyguide.org/ancient/lecture20b.
- Mason, C. 2000. *A Short History of Asia*. Palgrave Publishers, Hampshire, UK.
- Morales, F.J. 1999. The history of agricultural research and development in Latin America. CIAT Document No. 222, Palmira, Colombia.
- Morales, F.J., Palma, E., Paiz, C., Carrillo, E., Esquivel, I., Guillespiez, V., and Viana, A. 2003. Socioeconomic and agricultural factors associated with mixed cropping systems in small farms of southwestern Guatemala. *Journal of Crop Production* 9: 649–659.
- Mörner, M. 1970. *Race and Class in Latin America*. Columbia University Press, New York.
- Nickel, J.L. 1987. *Low-Input, Environmentally Sensitive Technologies for Agriculture*. CIAT, Palmira, Colombia.
- Odhiambo, T.R. 2001. Positioning African agriculture for the first decade of the twenty-first century. *African Journal of Food and Nutritional Security* 1: 3–11.
- O.D.I. 1994. The CGIAR: What future for international agricultural research. Overseas Development Institute, Briefing Paper.
- Olcese, O. 2002. Enfrentando la adversidad camino a la Gloria: 100 años de historia de la Universidad Nacional Agraria La Molina. Ediciones Universidad UNA'La Molina.
- Pardey, P., Roseboom, J., and Anderson, J.R. 1991. *Agricultural Research Policy: International Quantitative Perspectives*. Cambridge University Press, Cambridge.
- Persley, G.J., and Doyle, J.J. 2001. Biotechnology for developing-country agriculture. In: Pinstrup-Andersen, P. and Pandya-Lorch, R. (eds.) *The Unfinished Agenda*. IFPRI, Washington, pp. 239–243.
- Pinstrup-Andersen, P. 2001. Developing appropriate biotechnology policies for developing-country agriculture. In: Pinstrup-Andersen, P. and Pandya-Lorch, R. (eds.) *The Unfinished Agenda*. IFPRI, Washington, pp. 246–249.
- Pinstrup-Andersen, P., Pandya-Lorch, R., and Rosegrant, M.W. 2001. Global food security. In: Pinstrup-Andersen, P. and Pandya-Lorch, R. (eds.) *The Unfinished Agenda*. IFPRI, Washington, pp. 7–17.
- Reece, J.D. 1996. Natural resource management and the CGIAR System: Is progress possible? Paper for presentation at the 1996 Conference of the Development Studies Association.
- Restrepo, O., Arboleda, L.C., Bejarano, J.A. 1993. *Historia Natural y Ciencias Agropecuarias*, Tomo III. Colciencias, Bogota, Colombia.
- Roddick, J. 1989. *The Dance of the Millions: Latin America and the Debt Crisis*. Latin America Bureau, London.
- Smith, B.D. 1998. *The Emergence of Agriculture*. Scientific American Library, New York.
- Stiglitz, J.E. 2002. *El Malestar de la Globalización*. Taurus, Bogotá, Colombia.
- Thrupp, L.A. 1995. *Bittersweet Harvests for Global Supermarkets: Challenges in Latin America's Agricultural Export Boom*. World Resources Institute, Baltimore, MD.
- UN (United Nations). 2007. World population will increase by 2.5 billion by 2005. Press Release POP/952.
- World Bank. 2000. *A Better World for All: Progress Towards the International Development Goals*. World Bank, Washington, DC.
- Wortman, S., and Cummings, R.W. 1978. *To Feed this World: The Challenge and the Strategy*. Johns Hopkins University Press, Baltimore, MD.

CHAPTER 3

CONSIDERATIONS FOR DETERMINING RESEARCH PRIORITIES: LEARNING CYCLES AND IMPACT PATHWAYS

M.C.S. BANTILAN AND J.D.H. KEATINGE

International Crops Research Institute for the Semi-Arid Tropics (ICRISAT), Patancheru 502324, Andhra Pradesh, India

INTRODUCTION

Agricultural researchers identify and apply new science, novel approaches and innovations that could generate research breakthroughs and improve impacts to support the development of the agricultural sector. During the past few decades, there has been an expansion of the research agenda along the entire research-for-development continuum, with farm- and policy-level implications. The goals and objectives of research have broadened from primarily food production to include sustainable resource management, equity, gender, health, and environmental concerns. These changes have been in response to factors such as the changing regional and global environments, new science and innovations, the redefinition of research targets in the light of new findings, potential market opportunities, institutional learning, and the strengthened capacity of research. Along with the expansion of the research agenda, there is now greater appreciation of the need for quantifying the economic returns to research investment, and other dimensions of impact (social, environmental, and institutional). In accordance with these changes, priority setting in agricultural research has been rapidly changing too with the principal focus shifting from yield and nutrition gains to achieving impact on likely distributive effects and the environmental sustainability of alternative research strategies. New challenges have emerged in research management. If there is to be efficient use of scarce resources, particularly in the public sector, research priority decisions have to be consistent not only with informed scientific opinion or scientific possibilities but also with clients' needs and national and international concerns within the broader policy context. In promoting policies that improve the welfare of the people, especially in developing countries, the ability to set priorities and support correct decisions in agricultural research is critical.

Faced with these challenges, the pursuit of a well-balanced portfolio or a focused research agenda has become imperative. It motivates stronger accountability and objective, transparent priority setting. It prompts awareness among agricultural scientists and research managers about the expected benefits and payoffs from research. Increasingly, researchers and managers are compelled to provide solid evidence that they are using resources efficiently and effectively. Thus, the establishment of a transparent, consistent, objective, and participatory priority-setting process has become essential in institutional decision support and research planning.

This chapter presents important dimensions of agricultural research management, featuring the considerations that go into determining priorities. The first section discusses trends that shape the agendas of agricultural research organizations. A conceptual framework for priority setting in agricultural research is presented in the second section, embodying factors influencing impacts, their linkages, and minimum data requirements.

Another section gives an overview of priority-setting methods, ranging from simple statistical congruencies to economic models where both objective and subjective information are considered. Critical considerations in research evaluation and priority setting are addressed with focus on the difficulties encountered in practice.

Subsequent sections use the experiences of international agricultural research centers to illustrate the commonality of priority-setting requirements and processes. The international dimension of the discussion clarifies the role of international public goods and research spillover benefits across regions, as well as the relationship between regional and global priorities. The last section concludes with suggestions on institutionalization based on institutional learning and targeting for an informed approach to research decision-making.

RESEARCH PRIORITIES AS PART OF RESEARCH DECISION SUPPORT SYSTEMS

Agricultural research priority setting is a process involving analysis prior to investment, whereby estimation and ranking of expected future benefits assist research decision-making. Benefits from research investment in agriculture are expected to be realized when research is undertaken and the target users adopt the technology or the research results. The estimated relative benefit levels are compared across alternative options in a research portfolio. There are several levels of aggregation on which research options have to be ranked in order of priority:

- Agroecologies, regions, or countries
- Commodities, crops, or enterprise sector
- Research programs or themes
- Research projects within programs

- Research problems or productivity constraints
- Research needs/gaps

Depending on the level of aggregation required by the research organization, priority setting compares the relative importance of research at each level. It involves a process of explicitly or implicitly exercising a choice over possible research activities with the help of an array of available quantitative and qualitative information. The resulting judgments are expressed as a ranking of options within a research portfolio. Most agricultural research institutions conduct formal or informal priority-setting exercises to help set the research agenda, guide allocation of research resources, and improve the quality and efficiency of research. In national agricultural research systems (NARS), the priorities conform to national-level goals and objectives and are examined across commodities, regions, disciplines, and research problems. At the international level, spillover benefits across countries and regions, and the complementarities of national, regional, and international research objectives are additional concerns. The outcome of the priority-setting exercise is a ranking of commodity groups or agroecoregional zones at aggregate level; or research programs at institute level; or research themes within a program; or productivity constraints within a commodity project.

The benefits of systematic formal priority setting have been reiterated by Janssen (1995), Contant and Bottomley (1988), and Braunschweig (2000) as follows:

- Research objectives are better identified, and differences of opinion are clarified, thereby facilitating consensus building; team building and communication within the institution are improved.
- The chances of successful adoption of a new technology increase because stakeholders are included in the decision-making process.
- Useful information is generated regarding the changes that are necessary in the research environment; better information is used for educating the public about sensitive decisions, and managers are in a better position to defend their decisions, particularly against donors with a conflicting agenda.
- More emphasis is placed on longer-term impacts; informal priority-setting exercises often focus on short-term effects.
- Negative consequences are identified and corrective measures taken early to compensate for potential losses.

ESSENTIAL CONSIDERATIONS IN RESEARCH PRIORITY SETTING

While demands on the agricultural research agenda continue to increase, the last 15 years have seen changes in the funding environment, particularly a growing scarcity of research resources especially in developing countries. Inadequate funding of public agricultural research institutes is the most serious challenge

facing NARS. For example, investment in agricultural research in developing countries decelerated to 3.8% annually from 1981 to 1991 compared to a growth rate of 6.4% annually in the previous decade (Alston et al., 1995).

Changing support from traditional funding sources has also affected international agricultural research centers. In fact, while the expenditure of the Consultative Group on International Agricultural Research (CGIAR) has continued to increase in nominal terms since its establishment in 1972, in real terms it has stagnated, especially in the last 15 years. The rate of growth of the CGIAR's research expenditure has continuously declined during the last two decades. Estimates based on CGIAR Annual Reports (1975–2005) indicate that revenue and expenditure had begun to stagnate even before the 1990s, growing at an annual compound growth rate of 8% from 1975 to 1990, compared with a growth rate of 1.35% from 1990 to 2005. The nature of funding has also changed during the last decade. In particular, the proportion of unrestricted funding has continuously declined since the late 1980s while restricted funding has been increasing.

Research evaluation and expected impact pathway – framework for research priority assessment

An understanding of the whole research process is essential to facilitate agricultural research evaluation and priority setting. In principle, research evaluation is undertaken to confirm research effectiveness, efficiency, relevance, and impact. Priority setting is the process of ranking different research alternatives in order to identify a research portfolio in line with the mission of the organization or the agricultural policy of the country. Priority setting includes determining the relative importance of several research objectives.

This section illustrates the process of research evaluation and priority setting by tracing expected impact pathways (Bantilan, 2000; Joshi and Bantilan, 2000). The conceptualization of a framework (Figs. 1, 2, and 3) to guide the research evaluation and priority-setting process starts with the consideration of research investments to fund a set of specific research projects designed to develop new technologies for use by farmers (Fig. 1 on basic parameters for priority setting). This framework identifies the essential factors for priority setting.

If a research project does successfully achieve its objectives, it usually generates outputs in the form of (1) some new knowledge and (2) a change in the technology for use by farmers. To be more specific, the application of science-based technologies resulting from research is expected to bring about increases in yield and product quality of commodities/crops grown presently or subsequently. Research is also expected to improve the efficiency of input use via agronomic practices and crop management. Ultimately, these research-induced gains or changes in the production and consumption environment translate into an upgrading of the welfare of farmers who use the technology as well as of consumers who use the final products.

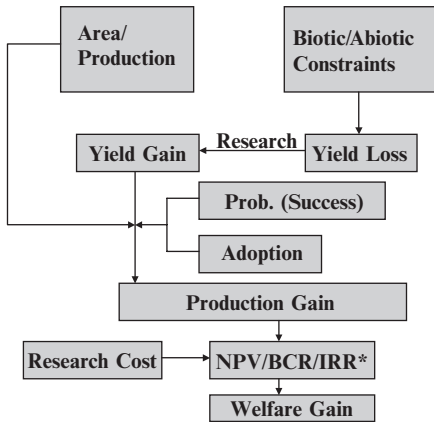

*Net Present Value (NPV)/Benefit-Cost Ratio (BCR)/Internal Rate of Return (IRR)

Figure 1. Basic parameters for measurement of welfare gains.

Before the final benefits of research accrue to society (i.e. producers and consumers), two important conditions must be met. First, the research undertaken must be successful in achieving its targeted objectives. This introduces the notion of the probability of success or relative research capability relating to the risk of an intended technological improvement not eventuating even after a significant period of experimentation or investigation. Thus, this framework enables judgments about the relative strength of research (capacity building) and extension systems (human resources) and rural infrastructure to be factored into the analysis. It also provides space for the consideration of other sources of uncertainty with regard to research success. Second, the increase in production promised by a new technology is ultimately achieved only when the technology is adopted and utilized by farmers. If the technology is not an improvement in some way over the existing technologies, farmers are unlikely to use it. In such an instance, the technology, although developed, is redundant. Yet, even if the technology is an unambiguous improvement, some farmers may still not adopt it. Thus, estimates of the rate of adoption of the results by end users must be carefully made. There may be several reasons for low adoption or slow uptake. One could be the reluctance of farmers to give up their existing, and in their opinion, proven practices. In some cases, adoption of technology may also be influenced by resource endowments. This condition necessitates consideration of the rates of technology adoption and the factors by which it is constrained.

The measurement of expected welfare gains to society is incomplete if it does not take into account the externalities which the technology involves. The externality consideration in this framework may either be negative or positive. Classic examples of negative externalities in agriculture are human-induced soil erosion and the detrimental effects of chemical-based technology. These include the deleterious effects of pesticides on the health of farmers and their families,

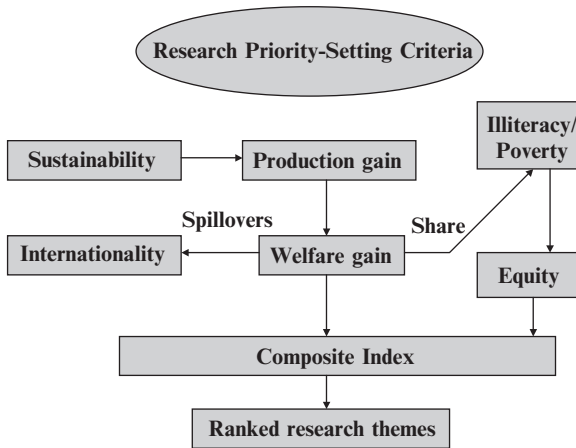

Figure 2. Linkages among four priority-setting criteria.

the transmission of chemical residues along the food chain to consumers, the toxic effects of chemicals on fish, shrimp, frogs, and beneficial insects in farmers' fields, the contamination of ground and surface waters, and the reduction of soil microorganism populations that help sustain soil fertility.

The positive externalities are incorporated within this framework through the concept of spillover effects (Bantilan and Davis, 1991; Bantilan et al., 2004), as shown in Figure 2 which presents the linkages of the overall welfare gain parameters (efficiency, sustainability, spillovers and other factors). Three types of spillover effects are possible. The first type involves across-location spillovers in which a technology developed through research for one product in a specific location can be adapted to improve production efficiency for the same product in another location. This type of spillover effect is relevant because the applicability of the new technology may not be the same for all locations, which may be differentiated by agronomic, climatological, or ecological factors.

The second type of spillover effect refers to across-commodity applicability of a technology. For example, a cultural management technique developed specifically for one commodity may also improve the production efficiency of other commodities

The nature of the first two types of spillover effects reflects the direct applicability of a technology across different locations/production environments and across different commodities. Thus, they are referred to as direct spillover effects.

A third type of spillover effect is referred to as indirect or price spillover effects (Brennan and Bantilan, 2003). Technological change relating to a particular commodity in a specific location brings forth increased supply, which may cause price changes. This in turn may have a price effect on other locations

(if the commodities are traded) or on related commodities. This is particularly relevant when the price responsiveness of the product demand is relatively small and/or the rate of product transformation among commodities is significant.

Following the basic parameters and linkages described above, a simple priority-setting procedure is outlined here to show the different phases of the exercise (Fig. 3):

- Clarification of research goals including identification of research domains, objectives/strategy, and critical constraints to agricultural production
- Identification of criteria for the priority-setting exercise (corresponding to research goals)
- Disaggregation of alternative research options at each level
- Elicitation of criteria weights through consultation with experts
- Choice of priority-setting approach: quantitative and qualitative measures
- Collection and processing of available data and resources: research gains, costs, probability of success, adoption levels, etc.
- Evaluation of potential impacts: assessment of expected research benefits based on the data collected and subjective judgments (e.g. environmental effects, impact on the poorer income groups, benefits for women)
- Sensitivity analysis using scenarios for the feasible range of parameter estimates or alternative criteria weights

The variables influencing the evaluation of potential research benefits or impacts may be based on measurable indicators as well as qualitative or subjective assessments. Quantitative or measurable indicators in agricultural research include estimated yield gains, unit cost reduction, research lags (i.e. timeframes for producing results), adoption lags, rates and ceiling level, and other direct and indirect effects on target and nontarget regions or sectors. Qualitative factors cover the probability of research success, effects on the environment or sustainability indicators. These measurements seek correspondence of the research goals and objectives, e.g. reduce poverty, improve food security, and promote sustainable natural resource management through agricultural research.

Other factors for consideration in enhancing the framework

Government policies

Existing government policies are an important factor, which can influence the welfare gains accruing from research. For example, governments of developed and developing countries alike have policies which subsidize production inputs like fertilizer, seeds, water, and electricity. In other cases, taxes are imposed on some agricultural commodities, especially cash crops like cotton, coffee, and tobacco. To estimate the gross social benefits of research when subsidies or tax policies exist, detailed knowledge of the policies is required. Alston et al. (1986) have shown the implications that various forms of price distortions can have for research evaluation. These policies influence the production and/or consumption of a commodity,

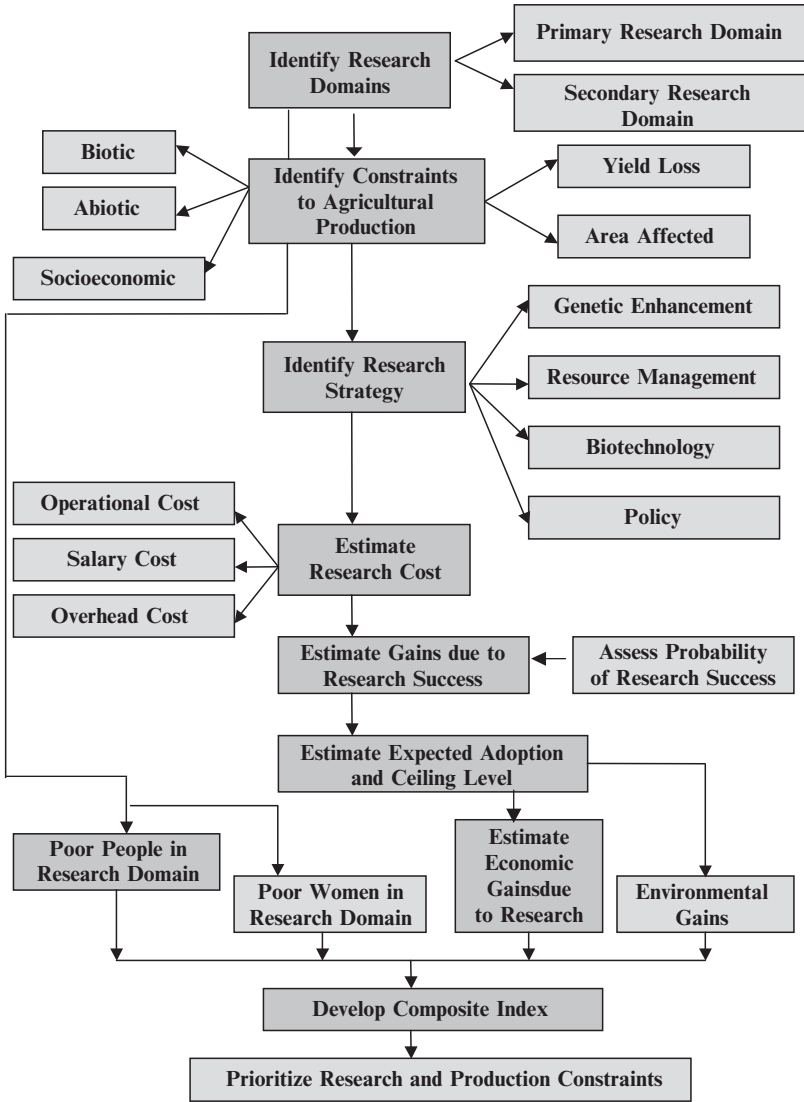

Figure 3. Essential steps in research priority setting.

or the inputs used to produce it. They can influence both the benefits flowing from research and the distribution of those benefits.

Expansion of demand and supply over time

Supply and demand of commodities can shift due to factors other than research. For example, population or income changes may result in a shift in demand for a commodity. Forecasts of demand and supply shifts can be made

to avoid underestimation of benefits if expansion of demands or supplies is expected over time.

Equity or distributive effects

Welfare effects from research can significantly vary across research efforts, regions, and commodities. Prioritization of research options is likely to be influenced by the distribution of these effects. It needs to be clarified which of these effects are important. For example, if several sectors are parts of one country and if the total national welfare gain is the objective of the research institution, then a measure of the potential research impact can be had by adding all the gains (or losses) in all sectors. If, however, the objective is to maximize gains to poor farmers only, then the subset of welfare effects in this particular sector is considered to give a measure of how well a particular research option may satisfy this objective. Estimates of these welfare changes, if quantified, can be summarized in a form suitable to assist decision-makers in setting research priorities or making allocation decisions. This information is combined with other information before decision-makers make final judgments about allocations.

Other aspects

Other aspects for consideration in priority setting may include: (a) effect on nutrition; (b) food security; (c) human capital development; (d) institution building and strengthening of national programs; and (e) employment generation effects. It is clear that a spectrum of considerations has to be taken into account for an assessment of research priorities. It is equally clear that a detailed understanding of the components of the research–evaluation continuum is necessary to arrive at a combined quantitative and qualitative assessment of impact. The expected outcome of research or its impact is dependent not only on quantifiable variables but also on others that are difficult to quantify.

Multicriteria nature of priority-setting processes

Given the multicriteria nature of the processes described above, priority-setting methods have evolved to support the complex decisions that must be made by research institutions. The complexity of priority setting is largely due to the multiple criteria involved in research decisions. As discussed above, research objectives and priority-setting criteria may include

- Productivity and efficiency
- Poverty and equity
- Gender concerns
- Environmental sustainability
- Trade-offs

Research managers must ensure the correspondence of research objectives with the set of criteria used for priority setting. In more complex decision-making,

a multicriteria decision-making process may be structured to consider trade-offs among research objectives relating to economic, social, environmental, and institutional concerns. This includes trade-offs between productivity and efficiency objectives versus poverty or equity or gender concerns or sustainability creation.

A multicriteria priority-setting framework has important implications. It requires attaching weights to each objective. This is the responsibility of senior research managers and policymakers. Their participation has become increasingly critical in the decision-making process. Appropriate procedures are needed facilitating interaction among decision-makers and for eliciting their preferences.

Mainstreaming poverty considerations in priority setting

Mainstreaming poverty considerations is an important issue in priority setting in the light of recent developments in the global research agendas of international organizations, which have identified poverty eradication as a common goal (UN, 2002; CGIAR, 2005). Mainstreaming poverty recognizes that there are at least five ways by which agricultural research can benefit the poor:

- Increasing poor farmers' productivity
- Greater agricultural employment opportunities for small farmers and landless workers
- Higher wages and growth in adopting regions
- Lowering food prices; and
- Greater access to nutritive crops.

This discussion refers to some points made by Ryan (2004) regarding additional considerations that need to be clarified in relation to poverty-targeted agricultural research priority setting. The first point is that it is not necessarily given that research investments targeted at the locations of the poor will achieve maximum impact on the resident poor. Many factors mediate this relationship and make it difficult to argue that priorities at the macro level should be primarily based upon the location of the poor. These factors include price effects, migration, and research spillovers in other regions. For example, where poor households in marginal areas are net food purchasers and the market infrastructure is adequate, technological change in more-favored areas can be an effective way of benefiting the poor in the marginal areas. Lower commodity prices result, and migration offers opportunities for low-income workers to participate in the benefits of higher wages and employment. However, as Fan and Hazell (2000) have shown, the marginal returns to research are higher in less-favored environments and also the effect of this on poverty alleviation is greater. Then it is not clear whether it is appropriate to neglect the less-favored areas and allow "trickle down" forces from more favored areas to equilibrate the benefits.

The second point for consideration is that the wage and employment effects of targeted research can be counterintuitive. In particular, if labor-intensive commodities have nonresponsive demands, then research on them could lead to mechanization or to their substitution in production by less labor-intensive commodities.

A third point raised is that growth linkages between agricultural and nearby rural industry can generate significant multiplier effects benefiting the poor most when agricultural income is a high proportion of total income. This has differential implications for targeted agricultural research in Asia and Africa. In Asia, there is increasing village-level evidence showing that a high percentage of rural workers are engaged primarily in nonagricultural employment. This is reflected in the inverse relationship between nonagricultural income and farm size, with smallholders, near-landless and landless workers deriving between one-third and two-thirds of their income from off-farm sources. Hence, they stand to benefit more from growth in the nonfarm sector than do the more affluent larger farmers. To the extent that nonfarm income is even more important for the poor in marginal areas, the issue arises whether agricultural R&D should give way to other interventions. In Africa the situation seems the opposite, with the rural poor depending more on agriculture than the nonpoor (Reardon, 1997).

By analyzing a typology of agricultural regions based upon agroecological zones and socioeconomic factors that condition the size and distribution of benefits from technological change, Haddad and Hazell (2001) identified five broad areas of focus for a pro-poor research agenda:

- Increasing productivity in less-favored lands, especially in heavily populated areas but also in high-potential lands constrained by poor infrastructure and market access
- Increasing production of staple food in areas where food price effects are still important and/or in areas that have a comparative advantage in growing these crops
- Helping smallholder farms to diversity into higher-value products, especially in areas where market prospects are good
- Increasing employment and income-earning opportunities for landless and near-landless workers in labor-surplus regions
- Nutritional enhancement of diets by investing in agricultural technology that reduces the price of micronutrient-rich foods; increase in physical access in remote rural areas, or increase in the nutrient content of food staple crops via traditional or transgenic technologies

Choosing an appropriate method

Research-evaluation and priority-setting methods have evolved from simple techniques used in consideration of single research objectives to systematic and formal mechanisms for assessing priorities corresponding to multiple objectives. A lot of effort now goes into evaluating agricultural research, due in part to the increasing complexity of problems, and in part to the tight research budgets and the resulting pressure for greater accountability. A large and diverse array of criteria has been employed by national and international organizations supporting agricultural research. These include: efficiency, equity or income distribution, food insecurity, per capita income, export enhancement, import replacement, among others.

This section presents an overview of the approaches used in priority setting. It features the various procedures used to identify and select the criteria for prioritizing research options and to identify measurable indicators as well as elicit subjective judgments. It includes novel techniques of quantifying the benefits from alternative research investments in order to facilitate informed decision-making on the utilization of agricultural research resources. This section also discusses several factors which influence the choice of priority-setting methods. The advantages and disadvantages of the different methods are mentioned as well as their suitability in different situations. In many cases, analysts combine these methods. Ultimately, they complement the intuitive judgments of research managers and administrators and the scientific intuition of scientists and researchers.

Different types of approaches have been developed for establishing research priorities (Contant and Bottomley, 1988; Davis et al., 1987; Alston et al., 1995): traditional tools (rules of thumb: precedence and congruence; checklist and scoring); cost-benefit analysis and economic surplus, mathematical programming and simulation models, among others.

Traditional tools

Rules of thumb

This approach is simple and quick, and needs minimal data. It is usually used as a preliminary approach ahead of a more formal priority-setting exercise. The two most commonly used methods in this approach are precedence and congruence. These methods emphasize the status quo and rely heavily on historical data. The precedence method uses the level of funding in the previous year as the basis for allocation of resources to project themes and projects. Allocations are marginally increased or decreased depending on the overall funding situation. Any excess resources available are distributed proportionately across research themes. This method can provide long-term continuity in funding of research themes and projects. However, one disadvantage of this model is that it continues allocating resources to areas that have reached the limits of their productivity even if the changing research environment may warrant a shift in funding. The precedence method is not forward-looking; it does not take into account emerging problems or any promising new areas of research or research investments that are likely to give the greatest impact.

Congruence models rank alternative research areas, commodities, or regions on the basis of a single criterion. The value of production is frequently used; and other measures include value of consumption, impact on total population and impact on poor people. The appropriate measure may be determined from the objectives and criteria of the research program. A review of studies, which used the congruence index in assessing research intensities and the relative importance of commodities, is provided in Scobie (1984).

Checklist

The checklist consists of a list of relevant criteria against which the research alternatives are checked. Like the two traditional tools described above, a checklist is often used as a benchmark or starting point in establishing the relative importance of research options. In practice, it may be viewed as an initial ranking of commodities (or research themes, projects), providing research managers some basis for discussion and further analysis. In many cases, these methods are combined with more rigorous methods.

Scoring

Scoring or weighted criteria are used to rank alternative research options according to multiple criteria that reflect multiple research objectives, as follows:

- The research alternatives are scored according to each criterion by using a discrete scale.
- The research objectives are defined, and weights are assigned to each criterion by the decision-makers.
- The scores are then multiplied by each criterion weight and then added up to determine the order of priorities.

Scoring models are widely used for priority setting because they are relatively transparent. When a meaningful conceptual framework is applied in scoring models, they can foster a dialogue considering research criteria and the weights associated with alternative research objectives. Useful scoring models should, at a minimum, incorporate basic economic principles into the priority-setting exercise. For example, economic efficiency measures such as net present value can be combined with equity criteria to rank research alternatives. A scoring model that is based on an economic approach incorporates the need to identify meaningful objectives, distinguish between weights and measures, recognize that research is a blunt instrument, and attempt to approximate economic efficiency measures (Alston et al., 1995).

Cost-benefit analysis and economic surplus

Cost-benefit analysis

The cost-benefit method for priority setting is a formal economic model that uses efficiency as the main criterion for ranking alternative research themes. There are three main steps in applying this model. First, the potential for generation and adoption of technologies is estimated for alternative research themes. A prime requirement is to establish, for the target cropping systems, the actual gains to be expected from the improved technology over and above the existing productivity levels achieved by the existing technologies in use by farmers. In addition, the relative value of the improved technology may be estimated from the viewpoint of environmental protection and cropping system sustainability. These data provide a baseline against which to estimate the gains that can be

expected from further improving the existing technology as a result of research or by direct application of known technologies.

Second, a stream of annual benefits and costs associated with each research theme is identified for the planning horizon. With discounting for factors such as probability of success, time lags, and ceiling rate of adoption, reasonable estimates can be made for the costs and benefits of a suggested research and/or development effort. Third, annual benefits and costs are discounted to calculate the project's worth. The latter is usually presented as a NPV or IRR. Technologies are ranked according to the values of NPV or IRR.

Cost-benefit methods indicate research priorities on the basis of efficiency criteria. This provides an insight into whether or not investment in research is making efficient use of scarce resources. This model can also be used to assess trade-offs in efficiency among research alternatives.

The narrow focus on efficiency is a disadvantage of this model as is its difficulty in capturing changes in the agricultural research environment. However, in priority-setting approaches based on multiple criteria, estimates from cost-benefit models can be integrated with other criteria. Besides a consistent ranking of research alternatives on the basis of efficiency, the process involved in applying cost-benefit models can force decision-makers to explicitly state the assumptions underlying technology generation and adoption for various research alternatives as well as explore the different impact scenarios on the basis of different assumptions. The basic data required for benefit-cost models are quantity and prices, assessment of the potential for technology generation measured by net yield gain, and the profile of adoption. Significant investments need to be made in collecting and analyzing this data although several computer programs have eased computation of benefit-cost estimates.

An alternative type of cost-benefit measure uses the domestic resource cost ratio (DRC). DRC estimates a given country's comparative advantage in producing a certain good. It calculates the cost-benefit ratio using the concept of opportunity cost, which indicates the social profitability of producing a certain commodity. However, this approach has major shortcomings as a single measure to allocate resources, ie, decisions based solely on a favorable DRC ratio tend to be biased against research investment in commodities that at present do not have a comparative advantage, e.g. future potential niche markets. However, the DRC approach is a relatively easy method of calculating the social costs and benefits of producing different commodities, and can provide complementary information for setting research priorities.

Economic surplus

The economic surplus principle is based on the idea that improved technologies are expected to enhance productivity or reduce the producers' unit cost of production, which translates into a shift representing an increase in the producers' supply when they adopt the new technologies. The calculation of the supply shift involves the use of available or estimated on-farm input and output data (e.g. yield

levels and input costs). Annual gains based on the empirical market benefits from adoption of the technologies are computed over the horizon at which the benefit is expected to accrue at anticipated adoption levels. This estimation only covers benefits accruing due to measurable market effects.

The economic surplus model is an enhancement of the cost-benefit approach to priority setting. It also ranks research alternatives on the basis of economic efficiency. Economic surplus models consider price responses to productivity increases induced by investment in research and technical change. These models also distribute the benefits from research investment between producers and consumers in the form of producer surplus and consumer surplus, each of which can be stratified by income or other socioeconomic criteria.

Approaches employing the concept of economic surplus to examine research priorities have been used in both national and international research assessments. National research programs usually assess priorities from the perspective of maximizing benefits that would accrue to the whole nation or to specific groups within it. These decisions may not be influenced by the additional benefits that may accrue to other countries or regions outside their mandate. An extension of the economic surplus method for assessing these international research spillover benefits is discussed below.

Multiregional international trade model

A multiregional international trade model using the concept of economic surplus has been developed to enable intercountry or interregional effects to be explicitly incorporated into an *ex ante* analysis of aggregate commodity and regional priorities in agricultural research (Davis et al., 1987). It employed techniques of economic surplus couched in an international trade model to derive *ex ante* measures of the relative benefits of alternative commodity and regional research portfolios and the distribution of these benefits among consumers, producers, importers and exporters. A novel approach of defining appropriate research domains has been identified to assess the spillover effect research undertaken in one region may have in other regions with similar agroclimatic and socio-economic environments. Further refinements in empirical applications have used Geographic Information Systems (GIS) to enhance spatial characterization and mapping of research domains. (Deb et al., 2004). The model also factors into the analysis the probability of success and the likely ceiling level of adoption by farmers. An empirical analysis using this model has been conducted for a broad range of commodities at an international level and includes all major producing and consuming regions of the world. (Davis et al., 1987; Lubulwa et al., 2000).

Other methods in practice

Two additional approaches in setting priorities have been developed, i.e. mathematical programming and simulation models. Unlike the two previous classes of research priority setting tools, which only produce a ranking of the research alternatives, these methods aim at selecting an “optimal” research portfolio and

establishing functional relationships between research investments and impacts. The basic approach in mathematical programming is to formulate an objective function that is maximized subject to certain constraints such as funding requirements, human resources, or institutional capacity. The objective function can include multiple objectives and a weighting system to reflect differences in the importance of the objectives. The results illustrate the tradeoffs among objectives and implications of changing constraints.

Simulation models are based on the principles of production economics whereby the functional relationship between the input (i.e. research investment) and the agricultural output is estimated. A production function may be used to represent the econometric relationship between agricultural productivity on the one hand, and research (and extension) expenditures and additional determining factors on the other. Then, the effects on productivity of various research expenditures, e.g. introducing different technological innovations, are simulated. Simulation models are very flexible, and can be used to analyze the wider impact of research investments. However, estimating econometric relationships is based on time-series data, which are not always readily available.

By and large, despite substantial efforts to improve the tools used in priority setting, only a few of the less sophisticated methods have been implemented by research organizations. Norton et al. (1992) explain it as a failure of economists “to communicate adequately to priority-setting practitioners the progress that has been realized on developing research performance measures and priority-setting methods.” In contrast, Shumway (1983) argues that “the perceived benefits to most organizations of the more sophisticated procedures are apparently outweighed by their cost.” Moreover, the extreme uncertainty surrounding knowledge production further limits the potential of sophisticated methods (Shumway, 1981). As a result, research managers often turn to simplified methods, knowing that data errors far outweigh errors caused by imprecise procedures.

Factors influencing the choice of an appropriate method

Following the three requirements suggested by Braunschweig (2000) in choosing an appropriate method, i.e. transparency, participation, and standardized measurement, the strengths and shortcomings of the different approaches are summarized below.

Use of rule-of-thumb approaches continues to decline with the availability of alternative procedures that can account for new research programs and the innovative nature of new science or new research areas with high potential. Alternative approaches, including cost-benefit and economic surplus analysis, mathematical programming, and simulation models, all require the research evaluation analysts to play the key role in the priority-setting process. It is in the scoring model that extensive participation at each stage, i.e. eliciting information, defining the criteria, assessing the alternatives, and establishing priorities, is required.

The cost-benefit analysis and scoring models are fairly transparent because, in both, the process of generating priorities is easily understood. Cost-benefit

analysis focuses on the economic impact of research. The other dimensions of research benefits are only included to the extent that they can be quantified in monetary values. Simulation models can also take into account a wider range of research effects. However, they do not provide a ranking of research projects based on multiple objectives.

Applied economic surplus analysis of welfare gains is being increasingly applied with the availability of data on yield gains, reduction of unit cost, or increase in income based on primary and secondary sources. The measurable economic indicators are complemented with qualitative data on expected environmental effects (e.g. farmers' perceptions of long-term environmental changes). This is also enhanced with a detailed account of both quantitative and qualitative information provided by scientists and experts, including farmers.

Both mathematical programming and scoring can incorporate many different impacts, including qualitative ones. The scoring model provides a systematic procedure by dividing the process into two steps: (1) scoring the contributions of the alternative research options with respect to each criterion; and (2) weighting the criteria. In the programming model, the decision-maker has to attach utility values directly to one unit of each criterion, a rather difficult task given the different measurement units of the criteria employed.

These methods continue to be used according to the requirements of research organizations, along with various trade-offs considered above. In the process, new approaches continue to be developed by research evaluation practitioners to overcome the shortcomings and methodological deficiencies experienced in practice.

Empirical applications in setting research priorities involve a combination of approaches. In practice, these approaches serve as complementary tools to guide research planning and resource allocation. For instance, the outcome of a cost-benefit analysis could be used as the input for a scoring model. Also, the programming approach could be used to allocate resources to priorities generated by the scoring model. The expected benefits that are amenable to quantification (e.g. expected yield gains or anticipated adoption rates) are quantified while descriptive documentation is used for those that are difficult to quantify. In the latter case, experts (including both researchers and research beneficiaries) are important sources of detailed descriptions, which may serve as the basis for qualitatively understanding the impact pathway and anticipated ultimate research impacts.

Inclusion of qualitative impacts in priority setting

Since research evaluation and priority setting involve the process of making choices in the context of scarcity, most of the studies mentioned above have placed emphasis on the economic principles of efficiency and on costs and benefits that can be expressed in monetary values. This has raised concerns because externalities, distributional effects, and longer-term impacts tend to be neglected with such an emphasis.

For inclusion of qualitative impacts in priority setting, a systematic process documentation of the impact pathways is useful in identifying the sources of the qualitative effects of technology adoption. It helps in clarifying the nature of impacts by considering whether or not the expected changes due to technology adoption can be valued using conventional markets, and therefore identifying variables that have market impacts and those that relate to nonmarket effects (Bantilan et al., 2005). A listing of the potential positive and negative effects aids in the analysis of the market and nonmarket impacts of alternative technology options. This is particularly useful for assessing qualitative effects and relative preferences among alternatives. It records the market impacts reflecting yield gains or reduced yield losses and changes in unit cost. The measurement of environmental effects in monetary terms within the context of economic surplus draws from changes in the social marginal cost of production (i.e. product supply) and the demand for the marketed product. The inventory of nonmarket effects may be substantial, e.g. significant positive effects may result in longer-term yield stability, or increased resource availability in the future. This potential change may adjust the farm-level benefit calculations for implicit price effects, which may be positive or negative, reflecting the environmental benefit or damage and a corresponding change in cost. A detailed account of the analysis of possible market and nonmarket impacts is presented in Bantilan et al. (2005). This study explains how conventional calculations that exclude environmental effects can skew measures of the full potential benefits from an improved technology. It illustrates the critical importance and use of qualitative information in understanding the environmental and long-term effects that may be expected from adoption of natural resource management technologies.

Using the results of impact assessment in priority setting: learning cycles and feedback process

Ex post impact assessment of research boosts the confidence of scientists, research managers, and stakeholders and makes a case for enhanced support for research. Information obtained during the process of impact evaluation can also help in research prioritization. For example, data from primary field studies provide a good basis for reasonable estimates of parameters, which are used in the priority-setting exercise. The essential impact assessment information includes: (1) levels and speed of adoption, and reasons for nonadoption of technology; (2) farmers' perceptions of desirable traits or features of technology options; (3) on-farm gains due to alleviation of biotic and abiotic constraints; and (4) infrastructural, institutional, and policy constraints in facilitating technology exchange.

Two categories of impact data may be developed. The first is a set of primary data on adoption and related variables generated from formal and informal on-farm surveys. The second is a set of secondary data based on documentation (published and nonpublished reports). On-farm reconnaissance and formal surveys may be primarily aimed at continuously assessing the extent of adoption

of improved technology from the secondary database. This confirms the extent of utilization of improved technologies by farmers in the target regions. Research lag is a major parameter determining the present value of research, and the cost of miscalculating it in terms of erroneous priority ranking can be significant. Verification of research and adoption lags used can be accomplished by cross-checking data from various sources.

Farmers' opinions on important constraints as well as their perceptions of desirable cultivation and management technology options may also be generated from primary surveys. These farmers' perspectives provide the following information: (1) they identify the constraints and research opportunities; (2) they provide an empirical basis for the expected ceiling levels of adoption, i.e. technologies introduced in an environment characterized by significant bottlenecks to adoption cannot be expected to have high adoption ceilings unless these constraints are addressed; and (3) they identify the research options that directly address the users' needs and are most likely to be adopted.

Estimates of yield losses due to important constraints and on-farm gains due to improved technology are also vital pieces of information for deciding research priorities. Impact studies can be used to validate estimates of expected yields. Furthermore, the estimates generated from these surveys (i.e. yield gains or unit cost reductions) also provide a way of predicting the potential supply shift, a necessary parameter for estimating potential impacts in cost/benefit analyses.

Another important outcome from impact studies is the assessment of researchers' perceptions or constraints, which can be technological, institutional, infrastructural, and policy. Two aspects are relevant for seed policy and priority setting: (a) standard variety release procedures of breeders' selecting materials that can make it through the formal release system; and (b) criteria for varietal release do not necessarily match farmers' needs and preferences.

In the process of documenting *ex post* impact using both primary and secondary data, it is possible to derive insights that can help better inform *ex ante* priority assessment and provide grounds for additional investment in the resultant research portfolio (Bantilan and Ryan, 1996). However, *ex post* experience is not the panacea when revalidating earlier *ex ante* assessments. At best, *ex post* experience can inform the *ex ante* process, hopefully in a way that helps minimize the moral hazards associated with scientists' estimates of their expected outputs and milestones.

Measurement problems

The unique empirical challenge of understanding the expected impact pathway is aggravated by problems of measurement. The approaches described above (like congruence, precedence, and scoring) appeal to single or multiple indicators of expected benefits, usually based on readily available, published data or subjective estimates of the level of relative benefits. Benefit/cost ratios combine the actual cost of research and development and technology transfer with the expected stream of benefits based on the levels of technology uptake or adoption.

The economic surplus principle is based on the idea that improved technologies are expected to reduce producers' unit cost of production which translates into a supply shift when they adopt the new technology. Thus, different measures yield different rankings, so the choice of criteria and corresponding measures is critical. The impact of different research alternatives on different criteria is measured on different scales. Some of these scales are inherently qualitative, which makes it virtually impossible to compare a unit of one criterion against a unit of another in a meaningful way. As Braunschweig (2000) suggests, a standardized measurement procedure allows the scores for different criteria to be aggregated in order to obtain an overall assessment of each research alternative.

Measurement problems also have a great bearing on the evaluation of more strategic research because it does not directly change productivity or production costs, yet this is a research area that has not been sufficiently tackled by traditional priority-setting approaches. For example, new knowledge generated by the research process, even if it may not be directly applicable in the productive sector, may still have substantial value in terms of strengthening scientific capacity.

Data availability and reliability

Relevant primary and secondary data are essential in ensuring objective priority-setting processes but data availability at the disaggregated level (or even at the national level) is usually constrained, especially in many developing countries. The problem of data reliability is pronounced because of the forward-looking nature of priority setting whereby expectations on key variables are required. This raises the issue of developing suitable elicitation techniques and identifying experts who can provide reliable subjective judgments on the likely costs, benefits, and other variables of research activities.

Minimum data requirements and database development

To identify the essential data requirements for research priority setting, this section uses the whole research–development–impact continuum discussed above. This continuum spans all stages from initial research efforts to expected impacts on farmers' welfare gains.

In agricultural research, the initial stages involve basic research, such as development of breeding populations and germplasm characterization. Subsequently, scientists engage in both applied research (e.g. development of seed-based technology with testing leading to an identifiable product) and adaptive research (the stages of testing leading to release of technology by the national agricultural research system). The final stages represent the development of optimal seed multiplication strategies and adoption of the technology, i.e. the final stages to achieve impact. This sketch helps in identifying the types of information and the minimum data set required for priority setting.

To illustrate further the identification of minimum data requirements, we use the specific example of chickpea biological nitrogen fixation (BNF) research,

starting with the identification of the research objectives, i.e. improving the nitrogen (N_2) fixing ability of chickpea. This involves the following activities (Bantilan and Johansen, 1995):

- Stage 1** involves the development of the concept of genetic alteration of the plant for better nodulation, through selection within existing cultivars. This stage leads to the basic concepts and methodology for the development of the improved technology.
- Stage 2** involves the actual conduct of the prescribed selection procedure to identify lines with superior N_2 fixing capability and their validation in on-station experiments.
- Stage 3** involves on-farm validation of the value of the selections. Note that stages 1, 2, and 3 represent the basic, applied, and adaptive research components in the development of this technology.
- Stage 4** is the demonstration, extension, and adoption of the technology among farmers. The process underlying the adoption of the technology characterizes adoption-related variables like adoption lag, rate of adoption, and ceiling level of adoption, as described below.

Introduction of a new technology is not usually met with immediate adoption. The gestation period between the generation of a technology and its adoption varies by sector, commodity, and type of technology. There are farmers who adopt only after the effects have been convincingly demonstrated. Farmers may hesitate to adopt a technology due to the difficulty in its use, nonavailability of the inputs required, market uncertainty, price fluctuations or preference for very low crop management technology. Thus, the level of adoption may be initially low, rising at an increasing rate after sufficient diffusion is attained, and finally reaching a ceiling level of adoption.

Based on the above sketch and the priority-setting framework described earlier, the basic data requirements and the steps required to develop the supporting database can be identified:

1. Identify the elements of the research portfolio to be prioritized. This may disaggregate by crops, research themes, programs, projects, or constraints.
2. In the case of commodities, assemble data by country or region on the area, production, and consumption of these commodities.
3. Define agroclimatically homogeneous regions.
4. Collect data on key factors involved in the various stages of the research process. For example, to estimate the expected impact for the BNF research illustrated above, previous average research experience shows that it takes around 5 years to undertake basic and strategic research, 4 or 5 more years to produce an improved variety, and another 5 or 6 years to reach the ceiling level of adoption (ICRISAT, 1992).
5. For computing estimates of the potential benefits of research, build on the research objectives and corresponding measurable criteria, which may require the following data:
 - yield gain
 - unit cost reduction

- production
 - consumption
 - adoption estimates
6. Estimate the probability of success of each research option.
 7. Assemble data on prices and price elasticities of demand and supply for each commodity. Include data on discount rates, exchange rates, transport costs, and potential spillover effects for traded commodities.
 8. Assemble data on research costs for measuring costs relative to research benefits.

Structured database

Systematic calculation of the measures of the various priority-setting criteria requires a structured database. The database developed from the research evaluation and priority-setting process contains comprehensive information on variables including research objectives, target research domains, estimated yield losses, expected yield gains, probability of success, adoption rates and ceiling levels, research and adoption lags, expected output, and manpower and capital requirements. This database serves as a benchmark or reference for research evaluation of future projects. This database should be continuously updated through impact monitoring.

Institutionalization

Research evaluation and priority setting within an organization involves a sustained effort to establish a built-in mechanism for setting priorities as part of the decision-making and research management processes. In this case, the management evolves a continuous cycle of priority setting with a defined and regular interval to provide an avenue of feedback and timely redirection of research. Establishing such a mechanism will require the following essential steps: (1) adaptation of a uniform methodological framework to assure comparability and consistency of identified priorities; (2) regular database update; (3) establishment of a monitoring process for performance, adoption, and impact; and (4) training to develop the capacity of scientists associated with priority setting. Training is essential not only to undertake priority setting consistently and objectively, but also to achieve transparency and active participation within the organization. Finally, in order to institutionalize and facilitate organizational priority-setting processes, *ex ante* impact analysis should be written into research proposals such that movement along the research evaluation and impact pathway continuum can be monitored, so that any necessary mid-course adjustments can be made and *ex post* impact assessments done. A decentralized process using nested institutional and project logframes may help to identify milestones for institutional and individual project evaluations.

Research priority setting: international dimensions

The international dimensions of research priority setting may be exemplified by the exercises conducted by the CGIAR. Its priority-setting initiative was driven by a determination to build an objective and transparent basis through its Medium Term Plans (MTPs). The 15 centers belonging to the CGIAR faced the challenge of a changing external environment where funds for research were declining, and pursuit of a focused research agenda became imperative. This change motivated stronger accountability and a search for an objective research priority-setting and resource-allocation process among the CGIAR centers operating around the world.

During the late 1980s to the early 1990s, the CGIAR Technical Advisory Council's (CGIAR/TAC) guidelines identified four basic factors for identifying agricultural research priorities. These included (CGIAR, 1988):

- Comparative advantage (e.g., the advantage that CGIAR has in undertaking projects where long-term, continuous effort is required)
- Internationality (i.e. the existence of externalities and spillover effects)
- Partnership (i.e. encouragement of intercenter and center-NARS activities)
- Efficiency and equity

The last factor especially related to total potential benefits and high expected payoffs, with consideration to the distributive consequences of successful research. This means identifying the area (ecological and geographical regions) and people affected, the benefits of research in relation to costs, feasibility of implementation and successful completion, and potential effects on the livelihoods of the poorer or marginalized sections.

The CGIAR evolved a structured priority-setting strategy aimed at reflecting its multiple research objectives. The determination of the priority research portfolio was built on an analytical priority-setting methodology based on a set of measures established for each of four criteria: economic efficiency or total welfare gain, equity, or distribution of the total welfare gain, sustainability, and internationality. Several CGIAR centers applied a similar set of criteria but evolved their own systems, depending on their requirements and capabilities. For example, a more significant effort for the 1994–1998 priority-setting exercise at ICRISAT, one of the CGIAR institutes mandated to target semi-arid tropics (SAT) research, involved application of a participatory approach. In this case, the problem was one of prioritizing among numerous competing research possibilities to make optimum use of scarce research funds against the background of a strategic plan. ICRISAT used an *ex ante* multiobjective framework, considering indicators for economic efficiency, equity, internationality, and sustainability, for assessing research priorities. A supply-side methodological orientation was used to complement the (CGIAR/TAC) demand-side analysis. The distinct advantage of the quantitative framework that was established is that at a time of intense competition for scarce funds, it makes explicit the benefits that would flow from additional investments to an institute as well as the opportunity

costs corresponding to reductions. The priority-setting methodology used for ICRISAT was found to provide clear criteria for establishing choices among competing research activities. It is more analytically rigorous, draws on scientists' empirical and intuitive knowledge base, and is transparent and interactive. Research themes were identified as impact-oriented, projecting clear milestones against which progress can be measured and evaluated. The assumptions about prospective yield increases, research lags, probabilities of success, and adoption lags and ceilings are tested against actual delivery of a new research-induced technology. This forms an integral part of the research evaluation process and facilitates revising priorities in the light of such experiences. This methodology was also later applied in other CGIAR centers (Kelley et al., 1995; Bantilan and Ryan, 1996; ILRI, 1999; IRRI, 1997).

In a follow-up MTP cycle 1998–2000, CGIAR centers pursued extensive discussions with partners where broad targets were identified that captured the areas of research and the nature of the benefits they intended to deliver through these partnerships during this particular MTP period. For example, four targets were articulated by ICRISAT:

Prosperity. Poverty is a fundamental cause of hunger, disease, environmental degradation, and a host of other afflictions. Since the majority of the poor in the SAT are engaged in farming or other agriculturally related enterprises, the road to prosperity lies toward the development of more productive and efficient agricultural systems.

Diversity. Poor farmers with small landholdings cannot afford the risk of being overly dependent on just a few crops or cropping systems. Diversity creates options; it spreads risk; it evens out peaks and valleys in labor use and income; it enables the creation of added value by expanding the application of farmers' management skills to new enterprises. More diverse, complex cropping systems are usually more robust and stable, and sustainable over time.

Environment. Environmental resources are the fundamental inputs of agriculture. The conscious or unconscious abuse of these resources can throw entire societies into poverty. This target has particular relevance to the SAT where poverty is a driving force behind short-term exploitation of the environment to satisfy pressing food needs.

Inclusiveness. Research products must be understood and valued by those who use them if they are to have impact. It is difficult to achieve this unless these stakeholders are involved in the identification of relevant research priorities, and in the research process itself.

The target of inclusiveness appealed to participatory methods to support the priority-setting process and decision support tools that facilitate the participation of stakeholders and allow them to express their preferences.

Subsequent 3-year MTP cycles followed, and the criteria used to rank priorities were more or less maintained across the CGIAR centers. The strategies and priority guidelines offered by the CGIAR TAC (later called Science Council) were influential in this evolution. The criteria broadened to consist of: equity,

efficiency, internationality, sustainability, new science opportunity, relevance to NARS priorities, and future trends which could change basic assumptions. Notably, major efforts continue to be launched to consult NARS partners and other stakeholders in the setting of priorities. The approaches to strategic planning and priority setting in the CGIAR continued to advance in the past few years, where the basis of priority setting has not only become more inclusive and participatory, but also increasingly appeals to process plans for strategic planning, impact pathways, situation and outlook analysis, periodic commodity and sector reviews, and more systematic understanding and foresight of the external environment and megatrends.

CONCLUSIONS

Priority-setting exercises have evolved in response to the need felt by scientists and research managers for simple and transparent procedures for making resource allocations to research projects. Research managers have come increasingly to realize that in order for research resources to be used efficiently and effectively, there should be a clear basis for setting research priorities. Complex considerations have to be weighed by the priority-setting process, and guidelines that are consistent with the broad agenda of research investment should be pursued for a problem-based, impact-driven agricultural research for development.

This chapter covered several important considerations that have to be weighed by the priority-setting process. It featured recent trends in the global agricultural research-funding scenario. These trends provide compelling reasons for a serious initiative among research evaluation practitioners to provide more systematic guidelines for research planning and priority setting. A simple research evaluation and impact pathway framework was discussed to identify the key parameters and minimum datasets needed for prioritization. Factors including government policies, expansion in demand and supply and other key issues not covered by the simple framework were discussed to feature some potential areas for enhancement. This chapter also discussed the multiple-criteria nature of agricultural research priority-setting processes, making a special mention of mainstreaming poverty.

The issue of choosing an appropriate method from among the several methods in practice was addressed with an overview of the various approaches and a discussion of their advantages and disadvantages and their suitability in different situations. It was shown that in many cases, analysts combine two or more methods and tend to complement the intuitive judgments of research managers and administrators with the scientific intuition of scientists and researchers. While measurable economic benefits lend strong support to the priority ranking of a research portfolio, additional considerations involving (a) the inclusion of qualitative impacts; and (b) utilization of *ex post* impact assessment in priority setting, were also elucidated.

As the analysis presented in this chapter demonstrates, the recent methodologies developed illuminate not only the relative economic benefits accruable

from alternative strategies but also the trade-offs which might be implied in the distribution of benefits. A good balance between theoretical rigor and practical feasibility in the priority-setting applications is needed. According to the availability of more disaggregated data, these approaches allow the determination of the distribution of benefits among the poor or nonpoor sections of the country. These considerations are of interest to policymakers who are required to make judgments on the allocation of scarce resources.

The final sections of this chapter expounded on the issues of institutionalization and the international dimensions of research priority setting in agriculture. It reiterated the message that in order to institutionalize and facilitate organizational priority-setting processes, *ex ante* impact analysis should be written into research proposals such that movement along the research-development-impact pathway can be monitored to enable learning so that any necessary mid-course adjustments can be made.

The information given in this chapter serves as an exemplar illustrating the assessment and prioritization of research projects, as per the differential nature of specific institutes. It demonstrates the need for more comprehensive measures that could be used to evaluate research priorities by taking into account the broad and diverse nature of research objectives today.

ACKNOWLEDGEMENT

We gratefully acknowledge the assistance of Anand Babu for the literature search and collection of expenditure data.

REFERENCES

- Alston, J.M., Edwards, G.W., and Freebairn, J.W. 1986. The effects of protection policies on research benefits. Economics and Marketing Branch Working paper series no. 20, Victoria Department of Agriculture, Melbourne, Australia.
- Alston, J.M., Norton, G.W., and Pardey, P.G. 1995. *Science under Scarcity: Principles and Practices for Agricultural Research Evaluation and Priority Setting*. Cornell University Press, Ithaca, NY.
- Bantilan, M.C.S., Anupama, K.V., and Joshi, P.K. 2005. Assessing economic and environmental impacts of NRM technologies: An empirical application using economic surplus approach, Chapter 11. In: Shiferaw, B., Freeman, H.A., and Swinton, S.M. (eds.) *Natural Resource Management in Agriculture: Methods for Assessing Economic and Environmental Impacts*. CAB International, Wallingford, UK.
- Bantilan, M.C.S., and Davis, J.S. 1991. Across-Commodity Spillover Effects of Research and Opportunity Costs in a Multi-product Production Environment. ACIAR/ISNAR Project Paper No. 30. Australian Center for International Agricultural Research. Canberra, Australia/ International Service for National Agricultural Research, The Hague, Netherlands.
- Bantilan, M.C.S., Deb, U.K., Reddy, B.V.S., Obilana, A.B., and Gowda, C.L.L. 2004. *Sorghum Genetic Enhancement: Research Process, Dissemination and Impacts*. International Crops Research Institute for the Semi-Arid Tropics, Patancheru, Andhra Pradesh, India.
- Bantilan, M.C.S., and Johansen, C. 1995. Research evaluation and impact analysis of biological nitrogen fixation. *Plant and Soil: International Journal on Plant-Soil Relationships* 174(1-2): 279-286.

- Bantilan, M.C.S., and Ryan, J.G. 1996. Using impact assessment in research priority setting: Developments at ICRISAT. Paper presented at the International Conference on Global assessment for science policy, 26–28 August 1996, Melbourne, Australia.
- Bantilan, M.C.S. 2000. Linkages among measurable criteria and sensitivity analysis for research priority setting: Learning from the experience of ICRISAT. In: Pal, S. and Joshi, P.K. (eds.) *Priority Setting, Monitoring and Evaluation in Agricultural Research*. National Center for Agricultural Economics and Policy Research, New Delhi, India, pp. 22–34.
- Braunschweig, T. 2000. Priority setting in agricultural biotechnology research supporting public decisions in developing countries with the analytic hierarchy process. Research report series no. 16. International Service for National Agricultural Research, The Hague, The Netherlands.
- Brennan, J.P., and Bantilan, M.C.S. 2003. Price and yield effects of spillovers in international agricultural research: Evidence from ICRISAT and Australia. *Agricultural Economics* 28(2): 87–97.
- CGIAR (Consultative Group on International Agricultural Research). 1988. *Medium Term Program Plans and Funding Requirements, 1989–93*. CGIAR, Washington DC.
- CGIAR (Consultative Group on International Agricultural Research). 2005. *Agricultural Research Matters: Achieving the Millennium Development Goals*. CGIAR, Washington DC. http://www.cgiar.org/pdf/cgiar_mdgs_brochure_2005.pdf
- Contant, R.B., and Bottomley, J.A. 1988. Priority setting in agricultural research. Working paper 10. International Service for National Agricultural Research, The Hague, The Netherlands.
- Davis, J.S., Oram, P.A., and Ryan, J.G. 1987. Assessment of agricultural research priorities: An international perspective. ACIAR Monograph no. 4. Australian Centre for International Agricultural Research, Canberra, Australia.
- Deb, U.K., Bantilan, M.C.S., Bantilan, F.T., and Gowda, C.L.L. 2004. Spillover impacts of sorghum research. In: Bantilan, M.C.S., Deb, U.K., Reddy, B.V.S., Obilana, A.B., and Gowda, C.L.L. (eds.) *Sorghum Genetic Enhancement: Research Process, Dissemination and Impacts*. International Crops Research Institute for the Semi-Arid Tropics, Patancheru, Andhra Pradesh, India, pp. 237–262.
- Fan, S. and Hazell, P. 2000. Should developing countries invest more in less-favoured areas? An empirical analysis of rural India. *Economic and Political Weekly* 35(17): 1455–1464.
- Haddad, L., and Hazell, P. 2001. CGIAR research and poverty reduction. Paper prepared for the Technical Advisory Committee of the CGIAR. International Food Policy Research Institute, Washington DC.
- ICRISAT (International Crops Research Institute for the Semi-Arid Tropics). 1992. *ICRISAT Medium Term Plan, 1994–1998*. ICRISAT, Patancheru, Andhra Pradesh, India.
- ILRI (International Live Stock Research Institute). 1999. *Making the Livestock Revolution Work for the Poor*. ILRI, Nairobi, Kenya.
- IRRI (International Rice Research Institute). 1997. *Annual Report 1995–1996: Listening to the Farmers*. IRRI, Metro Manila, Philippines.
- Janssen, W. 1995. Priority setting as a practical tool for research management. In: Bosch, M. and Preuss, H.J.A. (eds.) *Management Issues in National Agricultural Research Systems: Concepts, Instruments, Experiences*. Studies of the Center for Research on Regional Development, Justus-Liebig-University. LIT Verlag Münster-Hamburg, Giessen, Germany.
- Joshi, P.K., and Bantilan, M.C.S. 2000. Institutionalization of research prioritization, monitoring and evaluation. In: Pal, S. and Joshi, P.K. (eds.) *Priority Setting, Monitoring and Evaluation in Agricultural Research*. National Center for Agricultural Economics and Policy Research, New Delhi, India, pp. 65–81.
- Kelley, T.G., Ryan, J.G., and Patel, B.K. 1995. Applied participatory priority setting in international agricultural research: making trade-offs transparent and explicit. *Agricultural Systems* 49(2): 177–216.
- Lubulwa, A.S.G., Menz, K., White, D.H., Chudleigh, P., McMeniman, S., and Hill, D. 2000. Determining international agricultural research priorities. Australian Centre for International Agriculture Research IAP Working paper series no. 37. Australian Centre for International Agriculture Research, Canberra, Australia. [http://www.aciar.gov.au/web.nsf/att/JFRN-6BN8XF/\\$file/wp37.pdf](http://www.aciar.gov.au/web.nsf/att/JFRN-6BN8XF/$file/wp37.pdf)

- Norton, G.W., Pardey, P.G., and Alston, J.M. 1992. Economic issues in agricultural research priority setting. *American Journal of Agricultural Economics* 74(5): 1089–1094.
- Reardon, T. 1997. Using evidence of household income diversification to inform study of the rural non-farm labour market in Africa. *World Development* 25(5): 735–747.
- Ryan, J. 2004. Agricultural research and poverty alleviation: Some international perspectives. ACIAR Working paper no. 56. Australian Centre for International Agricultural Research, Canberra, Australia.
- Scobie, G. 1984. Investment in agricultural research: Some economic principles. Working paper. International Centre for Research on Maize and Wheat (CIMMYT), El Batan, Mexico.
- Shumway, C.R. 1981. Subjectivity in ex-ante research evaluation. *American Journal of Agricultural Economics* 63(1): 169–173.
- Shumway, C.R. 1983. Ex-ante research evaluation: Can it be improved? *Agricultural Administration* 12: 91–102.
- UN (United Nations). 2002. The millennium development goals and the United Nations' role. United Nations, New York. <http://www.un.org/millenniumgoals/MDGs-FACTSHEET1.pdf>

CHAPTER 4

CREATING AN EFFECTIVE PROCESS TO DEFINE, APPROVE, AND REVIEW THE RESEARCH AGENDA OF INSTITUTIONS IN THE DEVELOPING WORLD

RODOMIRO ORTIZ AND JONATHAN CROUCH¹

CIMMYT, Apdo. Postal 6-641, 06600 Mexico D.F., Mexico

INTRODUCTION

Agricultural research should be equally driven by society's interests and researcher's opportunity-creating capabilities, because economic, social, political, cultural, and environmental needs, especially in poor rural areas, should be addressed by the ingenuity of scientists orientated within integrated, problem-focused interdisciplinary research initiatives. Problem-solving research requires inputs from different parties across the entire value-chain that brings their perspectives, and maybe changes their views during a participatory consultative process in which stakeholders (including scientists) engage in practices of joint inquiry, collaborative and active learning, and adaptive management. Stakeholders of a research agenda are drawn from government (national, regional, and local), civil society (including farmers' organizations, non-governmental organizations [NGOs], and public concern groups), and the private sector (particularly small to medium sized enterprises). Collectively they should own the process for establishing the complex and evolving research agendas required for today's agriculture. Transparency for priority setting and accountability through monitoring and evaluation are required to ensure an effective research undertaking whether international, regional, national, or local.

The resource allocation process may promote a conflict against an agenda solely driven by one of the stakeholders that, for example, may focus on science per se (or basic research), instead of emphasizing problem-solving research that impacts on livelihoods. The latter, known as research-for-development, combines strategic, applied, and adaptive research agendas. Scientists today

¹ The views expressed in this manuscript are solely those of the authors and do not reflect the official policies of their present or past employing organizations.

in many public sectors' advanced institutions face the challenge of remaining in "blue sky" (basic) research that lacks an obvious problem-solving focus, or is unable to find a niche in the research-for-development continuum. Sumberg and Reece (2004) advocate that by conceptualizing and organizing applied and adaptive research activities, as the industry does toward "new product development", agricultural research will be better able to respond to enlarging agendas, increased expectations of impact, and declining budgets. Flexibility should also be built into the process to deal with unexpected fluctuations in funding and other external influences, plus the occurrence of new opportunities that fit into the mission. These factors are always present and shape the evolving agenda of any research organization.

The research-for-development approach replaces the old disconnected concept of "research and development" (Ortiz and Hartmann, 2003). A more intimate and iterative partnership between technology providers and product development and delivery agents should therefore be sought to ensure appropriate research planning and rapid uptake of research outputs. The research products ensuing from this approach are demand-driven, by end users and not supply-driven by "ivory tower" scientists. Hence, this new approach closes the gap between research and development (i.e. between innovation and impact), and ensures that development goals are driving the research agenda. In this approach research institutes, development organizations, the private sector, development investors, and governments are all partners sharing the same aim of accelerating agricultural diversification and commercialization for the agricultural sector. However, what must not be overlooked in this process is the need for substantial investments in product development research, prototype testing, and product delivery planning if research investments are to achieve real impact in livelihoods.

THE FORUM FOR SETTING THE RESEARCH AGENDA

Although, it seems that a participatory approach for defining the research agenda should be the norm, it does not always happen or it may become a source of conflict when stakeholders do not share the same views and a matching of interest does not occur between investors (or donors), clients (or research beneficiary), and the scientist. Such a research agenda for agriculture needs to be sustainable and profitable, particularly to get subsistence farmers into the market economy, and to get small farmers to become more efficient, productive, diversified, and wealthy. This agenda must ensure enough food and feed of sufficient quality, which may lead to healthy and productive people at a time that the world's population continues rising rapidly while the global profile of food demands is also dramatically changing. Given that this may be a difficult task for any specific group within the value chain, independent forums for research in agriculture have been established at the regional and global levels to help determine a consensus agenda.

The global forum for agricultural research

The Global Forum for Agricultural Research (GFAR) was founded in 1996 as a diverse community of regional and world organizations dedicated to harnessing agricultural research for sustainable development, a better environment, and the alleviation of poverty (GFAR, 2004). This forum aims to identify research priorities and opportunities for the various stakeholder groups participating in agricultural research-for-development. GFAR draws on the complementary skills and strengths of the stakeholders, and encourages inclusiveness while at the same time forging alliances and partnerships: from setting the research agenda through unbiased priority setting to assisting the implementation of products and measuring the impacts, which should lead to a true ownership by the various actors engaged in the whole process. The optimum model would then dictate that this global agenda would feed into and align with the agendas of regional and subregional organizations and in turn into national, thematic, and commodity-based groups.

However, the extent to which individual institutions align themselves with this agenda depends increasingly upon the degree of reinforcement from major donors. Moreover, the relative success of this approach is also confounded by the impact of activities by major NGOs and the private commercial sector. Thus, one of the greatest challenges in this area is not the defining of the agenda *per se*, but alignment with (as opposed to erosion by) the strategies of other major players in the same target domain. It is in this context, that a systematic value chain approach becomes highly valuable, so as to define the major elements and linkages impacting the product development, delivery, and impact following uptake of research outputs. In the past, it has been a great challenge to coordinate or converge the agendas of the many very diverse development investors. The Consultative Group on International Agricultural Research (CGIAR) plays a major catalytic role in coordinating these diverse agendas through science-based advocacy within a unifying framework of specific agricultural products and their role in stakeholder livelihoods. This role operates in two directions along the value chain: downstream toward product development and delivery but also upstream to encouraging advanced research organizations to focus on issues of direct benefit to those scientific pursuits that will drive future impacts in agricultural development. There is also an important opportunity to synergize this process by fostering South–South collaboration with advanced research institutions in the emerging economies of former developing countries.

The Global Forum operates at two levels; firstly, defining activities, projects, and programs that stakeholders agree to undertake jointly, which constitute the GFAR Business Plan; and secondly, supporting activities of the GFAR Secretariat to facilitate the implementation of the Business Plan – through dialogue, exchange of information, capacity building, and partnership facilitation. One of the key elements of GFAR plan of action includes the development of a global strategic agenda for agricultural research-for-development. Such an

agenda aims at facilitating the emergence of a new normative framework for agricultural research. The forum provides therefore a means for dialogue that lays the foundation for better understanding of global issues such as genetic resources management and biotechnology, natural resources management and agroecology, commodity chains, policy, and institutional development. This type of forum is excellent for setting priorities based on immediate needs. However, agricultural scientists also need to make strategic decisions about investments in activities that may have dramatic impacts in the 10–15 year time frame. Most importantly perhaps are areas of research that will open up substantial new private sector investments streams. Here the consultative bottom-up process may not be the most effective.

GFAR is not itself an implementing agency and its operations rely on joint undertakings with its stakeholders, prominently the regional and subregional forums. At the next level, national agricultural research systems (NARS), which should include or at least consult with, commodity groups, farmer cooperatives, and commercialization representatives should also be active in establishing national or local research agendas. This should be carried out in consultation with the regional and subregional processes and should focus their roles according to their respective comparative advantages.

Regional forums

A regional forum such as the Forum for Agricultural Research in Africa (FARA) relies on the constituencies of the African subregional organizations (ASARECA, CORAF/WECARD, SADC-FANR), which in turn depend on the respective national agricultural research systems. Such systems include national agricultural research institutes, universities, and NGOs working on agricultural development, agricultural extension agencies, civil society (such as farmer organizations), and the private sector (FARA, 2004). FARA and the subregional organizations ensure the ownership of the continental and regional research priority setting that could lead to enhanced efficiency and shared responsibility amongst their members. To accomplish their goals, FARA and the subregional organizations work together sharing information plus fostering and synergizing feedback mechanisms to sustain resources for research in agriculture. FARA acts as a professional body that gives advice in agriculture to policymakers across Africa. It also coordinates and facilitates the work of other international and national research organizations in the continent because of the strong support from its stakeholders sought through extensive consultations.

Regional forums can also influence the funding of agricultural research beyond its own constituency. For example, the European Forum on Agricultural Research for Development (EFARD) used the views of its sister southern regional forums (AARIRENA, APAARI, FARA, FORAGRO) when developing the agricultural-research-for-development component of the European Union “6th Framework Programme” with the aim of actively integrating

European research into the globalized environment that characterizes agricultural research at the beginning of this century (GFAR, 2001). In contrast, NEPAD (New Partnership for African Development) and the AU (African Union) both have similar representation to FARA and both have agricultural research agendas. However, the current challenge for these three forums is to ensure complementarity and mutual reinforcement of their respective strategies despite the different driving forces of their respective mandates. Similarly, many interest groups based on noncoregional mandates have convened consultative priority-setting processes (particularly in the area of biotechnology research), often with overlapping representation yet divergent conclusions. Seeing this counterproductive process, ASARECA have consolidated these into a unified biotechnology research agenda for their Eastern and Central Africa subregion. Other regional or subregional forums have had less success in this area due to lack of resources or unresolvable political divergences. Donors have at times been the most confounding factor in this process, sometimes canceling each other out through divergent or conflicting agendas. This raises the critical issue of the role of forums and research institutions in educating donors to fully understand all elements of the overall situation and the effects of their decisions. In addition, as regional and subregional forums gain in strength, more and more donors tend to align with their agendas.

PRIORITY SETTING AT THE INSTITUTIONAL LEVEL

Research priority setting may help research undertakings to be more relevant and to achieve greater impacts, thereby increasing revenues (Hartwich and van den Akker, 2000). However, it is often only when resources are becoming scarce that research organizations make a serious and systematic effort to prioritize their investments according to the needs of their clients (Alston et al., 1994). Priority setting, broadly defined for agriculture research, refers to the process of making choices amongst a set of potential undertakings to clearly outline research options and to allocate resources between these options (Mills, 1998). As a result of this priority setting a research system, institution, or program should be able to select the right portfolio of time-bound research projects to best serve its mandate, stakeholders, and comparative advantages. This approach contrasts greatly with the parallel process in the private sector, where market feedback is almost immediate and each change in operational process and agenda can be easily evaluated. However, there is no doubt that public sector research organizations such as plant breeding institutes, in their role of providing intermediate products to their respective value chain, must find ways of becoming more intimately and interactively linked to feedback and quantitative-success assessments from their end users.

Appropriate priority setting should lead to both enhanced relevance and improved efficiency in the use of research resources, especially at times of tight budgets (von Oppen and Ryan, 1985). Research priority setting may be a difficult

and costly activity because it requires substantial expert human resource investment in planning, consultation, and analysis of information. Nevertheless, it is critical to carry out this process comprehensively and empower stakeholders to guide resource allocation to result in useful knowledge and ensuing technology that address their needs. This also leads to greater transparency and mutual understanding. In addition, this enables stronger management, as a clear decision-making responsibility for implementing the research portfolio should ensue from a participatory priority-setting process in addition to the defining of clear criteria to measure research impacts when the knowledge and ensuing technology reach clients. However, the transaction cost of bottom-up consultative priority setting is rarely quantified. Thus, managers must pursue a fine balance between investments in consultative decision-making versus confidence in their own abilities to define critical niche areas of dramatic potential impact on stakeholders. This is particularly relevant for priority setting during periods of institutional financial crisis, which as mentioned above, is often the trigger for such processes. As in these cases, scientists are highly adept at compiling compelling justifications for business-as-usual scenarios within a supply-driven, self-perpetuation framework. Here, of course, is where empowered consultation with representatives from across the respective value chain can play a critical verification role. Unfortunately even this process is flawed by often being very pragmatic and short-term orientated and may miss the public good priorities. The latter can be readily resolved by the inclusion of NGOs and civil society representatives. The alternative top-down approach should involve a consultative foresight process that involves world leaders in the respective field (irrespective of their local experience and expertise) plus regional specialists.

A third approach is to carry out a quantitative *Ex ante* impact assessment-based priority-setting process, which may provide valuable data on which to build a priority-setting dialogue and thereby protect the process to some degree from the natural biases inherent in bottom-up processes due to the vested interests of those involved. *Ex ante* analysis, as with any priority-setting process, is highly dependent on having adequate reliable data. Such information is relevant for any type of decision-making and resource allocation process at the institute level. Combining *Ex ante* analysis with qualitative knowledge from stakeholders may provide a particularly powerful approach.

We are increasingly advocating a value chain/business perspective to public sector priority-setting/operational processes. However, this approach requires a stringent approach to assessing the missing or weak components or links in the rest of the value chain in which we are working. In particular, should some of these be considered excessively rate limiting or unlikely to be fixed, then the process must have the discipline to drop this part of the agenda and seek new opportunities. Conversely, if such an opportunity is adopted then a substantial commitment must be made to fixing those missing/weak components/links, either directly or indirectly through advocacy or assistance of others to do so. However, there is an essential component of due diligence and subsequent

follow-up that is required to ensure this approach is effective. This process must include an appreciation and monitoring of the essential roles of national partners, i.e. that the process should result in a complementary, feasible, and rational portfolio of activities in those partners. Moreover, that for any activities in new areas that an intimate and iterative skills development and technical backstopping program is established. The latter scenario is perhaps most important for activities requiring the development of commercial strength in existing (but poorly developed) or new product areas. There is often a tendency to conclude that certain areas have private sector potential and thus they should be left to market forces. However, this neglects the fact that in many developing countries the realization of market potential (particularly in resource-poor areas) cannot get off the ground without some initial public sector investment. Here agricultural research has a duty to invest in the development of public goods that will enable the indigenous private sector to develop these niche markets.

The outputs from research-for-development must be linked to a well-resourced, capacity-building program such that farmers will be equipped with plant and animal genetic resources and sustainable plant and animal protection or soil and water conservation options to cope with changing environments plus the entrepreneurial skills to assess and take advantage of any agricultural market opportunity. Research-for-development, keeping in mind the end users, also operates within a continuum that uses a “means” (research) for an “end” (development), thereby leading to impact on both, people’s livelihoods and science. In this context, target genetic enhancement research topics can be classified into four broad groups: stability (abiotic), resilience (biotic), productivity (yield), and profitability (added value traits and crops). With this approach, a new working culture can evolve in which managers internally reward the top performers following this framework, and externally encourage staff to broaden research alliances or partnerships for development. Effective networking should go far beyond the obvious potential partners, as organizations do not necessarily need to share the same ultimate goals in order to yield advantages from collaboration in their immediate objective area.

The evolving role of national chief scientist or institutional director of research

The 20th century was witness to a national research system that was influenced by chief scientists, who shaped the agenda through their interactions with policymakers. Likewise, powerful directors of research were the drivers of research agendas in international and national institutes. With the advent of globalization and calls for more transparency and a client-oriented setting of the research agenda, their roles are evolving, or sometimes they are being replaced by national, regional, or international forums (for chief scientists) or by councils or committees (for directors of research). For example, research (-for-development) councils or committees are becoming the highest apex for

policy research, institutional reform, and business development that reflects a new administration style for organizations operating in a more globalized research system. Such councils or committees represent the highest ideals of the organization and serve to guard its scientific and programmatic quality throughout the respective institutes. These councils or committees ensure quality, advise on tactical directions, and help scientists identify relevant funding sources.

In this new context, the directors of research have moved to a new dual role as advisors to research leaders or coordinators, and facilitators at large for implementing the research agenda of the institute. Directors of research should be therefore seen as the “catalyzers” for new initiatives. In their facilitating role for tapping resources, the directors of research should match the institute’s strategy, capability, and needs with donors’ interest.

These new research management arrangements also include research leaders or project coordinators, who may be elected by project members, who provide research leadership and assist in mentoring the project researchers. These research leaders provide scientific guidance and assistance in gaining funding for new project ideas, plus ensure project colleagues publish high quality articles or readily disseminate timely research results and other information to the broad range of clients the organization serves: farmers, entrepreneurs, and end users, as well as other stakeholders and development investors of the research institute.

The sections that follow provide examples on how international, regional, and national stakeholders (including the private sector) are able to set the agendas of their own institutions and influence the agendas of their partner organizations. In general there is a trend toward greater openness and transparency in the priority-setting process and greatly increased emphasis on end-user-driven priorities that are addressed through “problem-solving” research that directly serves the needs of their clients.

National systems, farmer organizations, and participatory research

The structural adjustment programs (between the end of the 1980s and throughout the 1990s) drove a change in the organization of public research in many national systems in the developing world. In most of the developing world, especially in Latin America, sub-Saharan Africa, and Central Asia, national agricultural research systems (NARS) initiated priority-setting processes in response to the fall in national budgets. Although many NARS continue to receive minimal funding for institutional infrastructure and human resources, most are now highly dependent upon project funding to carry out their research. This inevitably means that international aid donors or national private sector directly or indirectly skews the research agenda of these institutions. Public extension services in the developing world were often even more severely affected, leading to weakening or in a few cases elimination of their role. Voluntary organizations overseas (VSO) and NGOs that benefit from international aid, charity, or

philanthropy, became major new players for the uptake, adaptation, and implementation of research results and ensuing products, while also sharing their knowledge and exchanging technologies with farmers. Similar changes, brought upon by free-market economic theory and globalization, were already well underway in applied research institutions across the developed world. However, these institutions in the United States, the European Union (EU), and Australia were generally more robust and more able to adapt to the change. Thus, many NARS in the developing world are no stronger, or in some cases substantially weaker, now than 30 years ago. However, there are some notable exceptions, where NARS have grown substantially in scientific capability and financial strength due to dramatic increases in agricultural commodity exports (such as Thailand and Vietnam) or substantial increases in production in response to internal demand (such as Indonesia). This has generally been associated with a significant increase in private sector investment.

In short, the old system of a national government, through its Ministry of Agriculture or a national research institute, setting the agenda became old-fashioned and a more end-user-driven approach began to evolve often largely driven by donor demands through specific projects or project-based funding programs. In this way civil society groups, including farmer organizations, became particularly proactive in highlighting their needs to scientists in order to bring more wealth and health to the end-user groups they represented. This clearly provides a more “problem-solving” framework to research projects but often neglects the long-term strategic research required for future generations of applied breakthroughs. In this context, priority-setting forums, involving a wide range of stakeholders, including governments and donors, are now an essential element in ensuring the right balance and profile of activities within the agendas of research organizations. Where a conventional market is often not available to provide this type of feedback, these forums are critical for linking technology providers and end users. Specific details of how developing country national programs in India and Nigeria have handled this process can be found in the section on case studies, while examples from other countries are described below.

Farmer organizations cofunding agricultural research

The “empowered cofunding end-users” approach has been successfully demonstrated in a number of countries across a range of commodities. However, for brevity we just describe two globally recognized success stories from opposite ends of the development spectrum.

Wheat production in the Yaqui Valley (northwestern Mexico) during the 1940s was devastated by recurrent stem rust epidemics. Thus, in 1945 the Rockefeller Foundation established a resistance-breeding program under the leadership of Dr Norman Borlaug. Although local farmers were initially highly skeptical, they quickly adopted new cultivars based on Borlaug’s work and also became convinced of the importance of investments in applied agricultural research and

breeding. In 1955, the Yaqui Valley farmers received government support to purchase land and build a research and breeding station to continue this work. The new station was called CIANO (the Spanish acronym for Northwestern Agricultural Research Center), and the breeding program based there developed the wheat lines that contributed to the Green Revolution and were later acknowledged by a Nobel Peace Prize (Ortiz et al., 2007). CIANO later evolved into the Agricultural Research and Experimentation Board of the state of Sonora or “Patronato”, and today comprises representatives of all farmers, large and small, across the state of Sonora. Most importantly, the main source of funding for “Patronato” for more than 50 years has been the voluntary donations from farmers in the region which are calculated in proportion to their acreage. This success has served as an example for farmers from other regions to join hands with Federal and State Governments in Mexico. Mexican farmers play a key role in the process of problem identification and in determining research and technology transfer priorities (CGIAR TAC, 1998). Every program (or foundation) receives matching funds from Federal and State governments to complement funds provided by farmers. Grants are then competitively allocated to projects submitted to the State foundation boards by the National Agricultural Research Institute (INIFAP), universities, State and international research institutions operating in Mexico. Competition amongst research organizations for these funds has steadily increased, indicating that the empowerment of end users in the priority-setting process is a mutually beneficial arrangement.

A similar example but from a very different setting is provided by the Grains Research & Development Corporation (GRDC) which was set up in Australia in 1990 and became one of the world’s leading grains research organizations, responsible for planning, investing, and overseeing research and development, delivering improvements in production, sustainability, and profitability across the Australian grains industry (<http://www.grdc.com.au/>). The GRDC is a statutory corporation, operating as a research investment body in partnership with farmers and Government. Funding is provided through a levy on grain farmers. The funding level is determined each year by the grains industry’s peak body, the Grains Council of Australia. The Australian Government matches this funding, up to an agreed ceiling. The mission of GRDC is to invest in research and development for the greatest benefit to its stakeholders: grain farmers and the Australian Government. The Corporation links innovative research with industry needs. GRDC seeks a profitable, internationally competitive, and ecologically sustainable Australian grains industry.

The examples above show that this type of model for linking technology providers with end users can drive improvements in research planning and funding in both the emerging developing and the industrialized worlds. Today, farmers together with their respective national and local governments are playing an increasing role in setting the agendas and allocating their resources in agreed priority research areas that address their national and local needs. In most cases, farmers see the value of providing direct financial contributions to maintain this level of empowerment.

Participatory research

Decentralized (through disaggregated distribution of responsibilities across networks) and end-user participatory research with local partners may provide a new means for ensuring impacts of end-user-driven research in agriculture, especially when working in marginal, low input, stressful environments (Ortiz and Hartmann, 2003). This decentralization requires defining target areas, targeting local research partners for crop and resource management, and shifting responsibilities from a central research station to local undertakings. This may not only include technology testing but also new material generation through specific research for further selection and testing. In this way, individual research programs (irrespective of their size) will deliberately maintain diversity across locations. Such an approach should be driven by the needs of the rural poor to ensure such the work impacts positively on their livelihoods.

Agricultural research, aimed at increasing the cost-effectiveness and efficiency of production, must also follow an agroecozone approach with farmers participating with professional researchers in developing locally adapted technologies, which will need to rely on responsive local systems for dissemination to the farming community. New technology interventions need to assemble a set of characteristics that reduce yield loss and confer greater yield stability in the target areas. Input and output traits are included in a market-driven research agenda. Input traits such as resistance to insect pests, diseases (bacteria, fungi, viruses), and weeds, or acceptable performance in stress-prone environments (e.g. owing to drought, heat, or salinity) lead to yield stability, while output traits affecting quality and end uses provide new options for generating or improving people's incomes. Decentralized country-level research programs are mandatory because this type of research can only operate efficiently when close to the various targeted agroecozones for each crop. International and national research organizations, including VSOs and NGOs, should therefore play a facilitating role to allow farmer-participatory research to succeed.

AN ECO-REGIONAL CLIENT-DRIVEN AGENDA SETTING

Economic growth, equity, food security, and ecology are the four criteria for priority setting when nonresearch concerns guide scientists' agendas, but as suggested by Hartwich (1998), it may be better to use an end-user perspective when identifying the criteria to set the research agenda. Hence, a research organization needs to learn from the market place, and listen to farmers, retailers, processors, and consumers, as well as to interpret their feedback. It cannot ignore society as a whole since the state, through taxes and levies, generates income from agricultural production and exports and redistributes this income to the society or the environment. However, farmers and consumers are often concerned with immediate benefits leading to overuse of natural resources, which may affect the well-being of future generations. It should also consider other research organizations that use

research results as inputs for their own research, and the agenda will depend on both the geo-domain and the topic within the research undertaking.

A bottom-up priority-setting exercise for a research institute with an international agenda in agriculture should be based on the priorities developed under the strategic plans of the global, regional forums or subregional organizations, which in turn are based on NARS strategic plans. This collective knowledge and experience of both the research institute and its partners should be fully considered in any quantitative methodology used. Such a priority setting should be structured and justified on the basis of relevance to the target environments and users, the institute's comparative advantage, and the prospects for achieving impact. For example, priorities for crop improvement research, should ensue from expressed needs of research partners, farmers, processors, traders, and other end users after due consultation in several forums such as networks or collaborative meetings, symposia, workshops, and farmer field days, as well as baseline studies for some crops in target environments. Additional objectives for crop improvement research may also be included, according to market and end-user demands, such as nutritional qualities and other postharvest characteristics.

The CGIAR conducts strategic (mission-oriented) research consistent with its goals and where it has a comparative advantage that leads to international public goods (IPG), which benefit all or more realistically many nations (Ryan, 2006). Traditionally, IPG that are of interest to the CGIAR are those that benefit many countries, and seldom attract private sector investments. During the last decade, the CGIAR system has initiated a wide range of initiatives to enhance cost-effectiveness, science quality, and impact on the poor (Shah and Strong, 1999). Most recently, the CGIAR's vision and strategy has focused on enhanced collaboration with national and regional partners, within a regional approach (de Janvry and Kassam, 2004). It is interesting to note that the founding CGIAR centers were established under a 30-year disengagement vision whereby the international agricultural research centers of the CGIAR would be replaced by regional centers of excellence. These regional agro-ecozone centers of excellence should reflect collaborative undertakings between international centers, national programs, and local private sector as a result of a priority setting that engages regional stakeholders (Ortiz and Crouch, 2004). Meanwhile, the Science Council was created to ensure that science in the CGIAR is of high quality and is relevant to the development goal of the System. The Science Council also provides independent, credible, and authoritative advice and opinion on strategic scientific issues relevant to the international agricultural research domain, helps to develop partnerships with the wider scientific community, and assesses the impact of knowledge and ensuing technology of the centers that reach clients worldwide (Kassam et al., 2004). The CGIAR centers' plans aim to align with the Millennium Development Goals, which guide the allocation of resources by the "international aid industry", especially in regional or national projects.

While undertaking research-for-development to address the needs of the rural poor, the CGIAR centers or similar organizations will need to dialogue with

national, regional, and international partners from private and public sectors as well as “civil-society” representatives. Regional centers of excellence offer ideal hubs for building the necessary networks and partnerships. To ensure sustainable local capacity in research-for-development in the long term, the organizations closest to the target beneficiary must work in coordination with those along the full research-for-development continuum. In this type of partnership mode, everyone is then encouraged to define his or her own comparative advantage niche area in the continuum and focus the maximum effort on this area, although then retaining the necessary time commitment during their priority setting and review processes for intimate and iterative contact with representatives across the entire value chain. Clearly, it is most efficient and powerful when such value chain committees are created, governed, and staffed by unbiased third parties. In this case, all members of the value chain can most efficiently tap into this central independent committee as opposed to creating their own. Moreover, the power of committees is substantially enhanced under these circumstances and offers the opportunity of closing the loop and filling the remaining rate limiting factor regarding subscription and reinforcement of priorities set by such committees by the major donors interested in that area. Some donors have already committed to this process, by making it a primary criterion for potential grantees to demonstrate how well their project proposals align with the agendas defined by key international priority-setting bodies, e.g. the Science Council of the CGIAR. With such community coordinating processes in place, it is then plausible that this approach will also offer leverage with donors not previously focusing in such areas.

The need for involvement in such agenda setting organizations becomes ever-more important as the geographical proximity between technology providers and technology users increases. Here there is less-tendency for upstream research institutions to become directly involved in downstream activities in their target regions. However, there is a tendency to become increasingly isolated from downstream input in priority setting and review whereupon the impacts of upstream research will be low if activities are not driven by downstream needs. Thus, the overall conclusion is clear, upstream institutions are rarely good at downstream activities and vice versa, thus partnerships operating under the orientation and empowered feedback of value chain community bodies may be the most effective way forward. There is therefore no justification – in terms of costs and sustainability – for an organization to come from afar to remotely carry out downstream activities related to its research outputs; i.e. on the development side of the research-for-development continuum (Ortiz and Hartmann, 2003). Thus, the partnership approach must prevail, whereby the agroecozone (or global) challenges dictate which partners and respective CGIAR centers will collectively determine the best way to address the problem according to this engagement protocol. This means CGIAR partnerships should be tailor-made to meet a particular challenge rather than maintained to serve more generic and detached goals.

Defining the implementation team

In this regard the research organization should identify a target population of end users in a defined agroecozone based on an analysis of rate limiting issues adversely affecting the commodity-specific value chain to livelihoods that can be improved through research-based activities. Together with key partners, such research organizations must integrate the research-for-development agenda into an achievable operating framework that leads to impacts on the war against poverty and hunger through improved livelihoods. Such an approach must be defined by respective comparative advantages (from local to global) based on competitive edge (i.e. the “niche” of each partner) and bring other actors (from indigenous to foreign) as needed in problem-solving plans. At the same time, it is essential to define a priori the currency of the impact that is being targeted, and will thus be used in subsequent monitoring, review, and evaluation. At different stages along the value chain, institutions may be aiming for increased stable and resilient productivity, reduced poverty, improved food security, and reduced hunger, or improved livelihoods. Hence, in this model the CGIAR fulfills multiple roles as a *catalyzer* that brings new and improved technology, as a *bridge* by leveraging the knowledge gap through training national and regional manpower with the necessary new skills required to best utilize those technologies, as a *broker* of (proprietary) technology exchanges, as an *advocate* to ensure a well-informed local leadership, and as a *synergizer* to help ensure that all components and linkages in the value chain that are essential for impact of those technologies are properly functioning. One important issue for public sector research organizations to internalize is that of comparative advantage niches, which dictate that, for example, the effective delivery of products from research is usually best, achieved by NGOs and the indigenous private sector.

Driving impacts from science to improve african livelihoods

The overall rationale, for establishing the International Institute of Tropical Agriculture (IITA) was to find ways to enhance yields and quality of African tropical food crops other than rice; to provide in collaboration with the strongest university in the region (University of Ibadan), a high level of professional training, and to be a pacesetter that improved the effectiveness of research, training, and extension of other organizations in the region. Based on this framework, defining the most appropriate agenda of a international research-for-development public organization such as IITA, it is critical to constantly re-evaluate recent advances in science and new available technology options, while also cross-comparing with other providers and actors that can supply technology, information, knowledge, and skills development to actively synergize the work of IITA. However, prioritization and implementation of IITA's research agenda also depends on the political, social, economic, and environmental factors, both within the mandate region and globally (CGIAR TAC, 2001). This must

incorporate both stakeholders' views and end-user demands, within a defined farming systems context. Moreover, this requires the formation of intimate and iterative linkages with those NGOs, NARS, and small-medium enterprises (SMEs) who will play a key role in delivery of research outputs from IITA and partners. In this respect, the success of IITA's activities is highly dependent upon the creation and coordination of functional linkages along the entire research to development continuum, in other words, synergizing the value chain from advanced research institutes (ARIs) to farmer's fields and beyond.

Changes in external pressures and opportunities plus evolving management teams are usual for dynamic organizations that aspire to influence others (Ortiz, 2005). Thus, the main role of science in agriculture has been to guide the evolutionary process to allow more production with less land and less labor (Douthwaite and Ortiz, 2001). This research-for-development philosophy also considers a "small landholder development trajectory" from subsistence to commercial scale in which the farmers are heterogeneous and research products help them to move along that trajectory (Ortiz et al., 1999). Opportunity and vulnerability factors determine what technology may be the most appropriate in the landholder development trajectory. Researchers therefore need to offer a broad array of products because low-input environments require a yield-stabilizing technology, whereas matching technology to achieve high-yield potential should be developed for high-input environments. Such a differentiated target needs to be addressed by a heterogeneous and dynamic strategy that will change at various points in response to changes in external pressures, client needs, and new technological opportunities. Researchers along this trajectory must use all available research tools to provide diverse options to help all farmers in sub-Saharan Africa to move onto the next stage from their respective positions in the trajectory. By stimulating consumer demand for crops and their products, and satisfying farmers' immediate domestic needs, farmers will be assured of profitable outlets for their produce, and the associated cash earning opportunity. Increasing productivity per unit area leads to more food, extra produce for sale, and the possible inclusion of other crops due to enhanced productivity on the land. Likewise, the higher and more stable yield potential and profitability permits poor farmers to invest in inputs for producing more food and income, whereas high yield may lead to reduced food prices for the urban and rural poor, which leads to monetization of rural areas, whose inhabitants may prefer "money in the pocket" (income generation) rather than only "a meal on the table" (food security). Furthermore, high-yielding crops may provide employment for poor people throughout the trade chain (from harvest to processing).

Selecting a target model of economic development

Hartmann (2004) argues for local production because it is the most stable way to improve livelihoods, increase food security, and contribute to long-term and broad-based economic growth. By taking this approach, IITA also addresses

food security issues, which are directly related to poverty. Focusing on local production is also needed because the alternative is food imports and that is not without limitations because such an approach does not fully accommodate nuances of geopolitics, climate, food preferences, global and regional trade, availability of foreign currency, as well as available information and infrastructure. The wealth creation concept according to Hartmann (2004) is to take what farmers already produce and use it to earn more income. They can be helped to sell it at the next rung on the ladder. If farmers increase crop production, IITA research-for-development should create outlets for their produce. Simple agro-processing of crops such as banana or cassava can double or even triple incomes. Similarly dual-purpose crops, for food and feed (Singh et al., 2003), lead commodities into other users and places, which provides another powerful poverty reduction concept: the expansion of markets through the creation of new outlets contributes to price stabilization without the need for costly government programs. Producers face risks that need to be managed. The poorer the farmers, the more limited their ability to deal with these risks. Addressing them, Hartmann (2004) says, is an important strategy for poverty reduction. Like anyone else, farmers, rural families, and the poor try to avoid or reduce their risks. Here is a critical point where investor choices determine options. IITA categorizes the risks faced by producers and rural communities into four broad groups: biological, commercial, natural, and political. In the decision process under the IITA approach, preference is given to research-for-development methods that are less dependent on policies, inputs, costly government programs and services.

Defining and evaluating the agenda-setting process

IITA pursued an informal priority-setting process that follows consultative interactions with clients in the formal sector with NARS partners, but also in direct exchanges with clients or end users such as farmers, or sometimes consumers. The interaction with farmers and consumers shaped the need for adding agro-processing for transforming a research output into usable forms for both farmers and consumers. The successful biological control of crop pests in cassava and mango, and water hyacinth are examples of this IITA approach (Neuenschwander, 2004). The prerequisite for the success of such knowledge-intensive programs is the nature of investor support and financing. It is difficult to implement biological control options successfully without long-term commitment to knowledge generation. Indeed, the largest development impact in sub-Saharan Africa came via support of long-term crop improvement and integrated pest management research dealing with biological risks (Maredia and Raitzer, 2006). The most recent impact report to the CGIAR Science Council indicates that about 80% of the US \$ 17 billion estimated impact of the CGIAR in sub-Saharan Africa result from the biological control of pests by IITA and national partners across the region (Maredia and Raitzer, 2006). This is a truly

awesome success and as such it is appropriate that one asks the question “what factors and players were important for the agenda and priority-setting process that led to this long-term endeavor. Not surprisingly the answer is complex, since a broad range of actors can be acknowledged: scientists who were on target with their ideas and translating them into research undertakings, stakeholders/clients who guided their priority setting, managers who supported the scientists and sought the resources for implementing their research, and donors who were convinced by the arguments from IITA managers and scientists and were then willing to invest in the agenda of the Institute.

The available impact research compiled in this report shows also that West and Central African farmers benefit by growing about 2 million hectares of maize (about 37% of country weighted average) bred by IITA and partners in the subregion due to yield increases of 45%. Long-term research by IITA and African partners led to the development of improved, high-yielding Tropical Manihot Selection (TMS) cultivars that increased cassava yields by 40% without the use of fertilizer. This Pan-African partnership throughout the cassava commodity chain impacts crop output in the world because of the significant gains in the fields grown by African farmers. They are not only contributing significantly to the African diet but also propelling entrepreneur development through agro-processing of this crop (Dixon et al., 2003). Both examples point out the benefits of having a CGIAR ecoregional center doing crop breeding, and together with many continental partners delivering the new seeds that impact on African livelihoods. Clearly, there are some circumstances where NARS are already sufficiently developed to fulfill this role. In such cases (and the list will hopefully be rapidly expanding), the CGIAR centers have a duty to rapidly devolve these activities to the national partners through technology and skills exchange.

Clearly, this ecoregional approach for research shows advantages both for the research organizations (international centers and regional or national partners) as well as for the clients (investors or donors, and local end users) Such an approach, as shown by the examples from IITA, brings the advantages outlined by de Janvry and Kassam (2004), because it achieves economy of scale in research, internalizes the international externalities of investment in research and development, elevates the game to maintain longer term continuity, gives coherence to donor-driven projects, and provides accountability and resilience to capture. In this regard, by ensuring appropriate coordination, participation, and partnership with the broad range of stakeholders, the lack of experience, data or information, and funding support may be overcome due to the end users’ ownership of the research-for-development undertakings by the scientists.

INFLUENCES AND OPPORTUNITIES FROM SUPRA-ACTORS

International and national science or research councils, external reviews, investors or donors, and competitive grant systems also shape the research agenda of scientists. In North America, Europe, Australia, and Japan, the National

Research Councils (or similar entities) play an important advisory role to their government on research matters, and allocate public resources to scientists through competitive grants based on peer assessment of their research applications. Public funding is given to those proposals judged to be of the best quality by the relevant research community, and according to the national science and technology policy. In this regard, the US Government during President Clinton's term in office used the budget to refocus science and technology policy to support US competitiveness in the global market place (Nameroff, 1997). Similarly, since the 1970s the EU (particularly Germany), and Japan have focused public funding on applied research and adoption of technologies that will enhance their economic growth rather than on fundamental research. There are also initiatives from the developing world to set up their own funding mechanisms to generate relevant agricultural research that suits economic needs. For example, the Fondo Regional de Tecnología Agropecuaria (FONTAGRO) was set up by the Inter-American Development Bank and several Latin American and Caribbean member states to allocate resources through a competitive grant system for regional collaborative research on agriculture and food science innovations with the aim of addressing competitiveness (especially for export trade), poverty (mainly in rural areas), and sustainable management of natural resources (FONTAGRO, 2004). Similarly, in many countries the research grants of levy-based commodity groups exert a highly product-driven perspective on their grantees, which in turn influences the research framework of those institutions with substantial commitments to this type of funding.

The Millennium Development Goals (MDG) were born after the historic Millennium Declaration adopted by 189 countries at the United Nations Millennium Summit in September 2002. The MDG called for the elimination or reduction of poverty and hunger, universal education, gender equality, improving the health of mothers and children, combating diseases, sustainable use of environmental resources, and development of fair and open trading regulations and global partnerships. The MDG are now guiding the investments of the "international aid industry", including their funding to research organizations dealing with international agriculture development.

The MDG and the recent CGIAR system priority setting (CGIAR, 2005a) are having substantial influence on the shape of any strategy and medium-term plan project portfolio of the international centers conducting research in agriculture. The Science Council of the CGIAR initiated this system-level priority setting in line with its aim to help develop a more cohesive and better-focused, high-quality research program to alleviate poverty, hunger, and malnutrition. The two main reasons for this initiative were to ensure a greater impact of the CGIAR centers through a more consolidated research focus and to avoid dispersion and redundancy of research agendas at a time when there is pressure for the goals of the CGIAR to widen, while at the same time its total budget in real terms is reducing. Moreover, the considerable and widespread shift from unrestricted to project-based funding is considerably complicating centers' ability to retain a

sharp focus. The multipronged approach of the priority setting followed by the Science Council was both analytical and broadly consultative with stakeholders (CGIAR, 2005a). The Science Council reviewed the total research portfolio of the CGIAR projected to 2015 and sought to focus the CGIAR research agenda on five priority areas for research: sustaining biodiversity for current and future generations; producing food at lower costs through genetic improvement; creating wealth among the rural poor through high-value commodities and products; combining poverty alleviation and sustainable management of natural resources; and improving policies and facilitating institutional innovation. The Science Council together with the CGIAR Secretariat further review and refine this agenda at the center level through External Program and Management Reviews (EMPR) of the centers. Prior to the EMPR of any center, the Science Council seeks the views from the CGIAR membership (mostly the investors for each center), other clients, sister CGIAR centers, and the CGIAR Secretariat that assist in defining the issues to be addressed during the review, in addition to generic matters covered in the terms of reference of each review team (CGIAR, 2005b). The CGIAR centers also commission external reviews (CCER) on selected research topics or management issues. Such CCER are a tool for the Governing Boards to facilitate their oversight roles including the relevance and quality of science. The quality and utility of the CCER may vary but surely their recommendations can influence the agenda of the centers, especially when based on feedback from partners and clients of the centers.

Focusing on the primary product and comparative advantage niches of the institution

The International Maize and Wheat Improvement Center (CIMMYT) was established in 1966 to build on the successes of the germplasm and knowledge generated in relation to improved crop management by 1970 Nobel Peace Prize winner Norman E. Borlaug and coworkers in Mexico. In 2003, CIMMYT entered an intensive “soul-searching” phase triggered by financial constraints. As a consequence, the Center established a new program structure to bridge disciplinary and commodity (maize and wheat) divides that often occur among most large research centers. At the same time, the new operational vision required CIMMYT scientists to frame their activities in the context of a value chain in which CIMMYT’s improved wheat and maize germplasm was just one component. This strategy was the result of a highly participatory process including empowering partners as an essential prerequisite to building the trust necessary to enact the new vision. Moreover, the new vision and strategy embraced a whole new way of working, particularly with partners. The need for this change can be directly attributed to the need to operate in the context of a value chain or more precisely a value web where failure in any component, and more importantly any linkage, will affect the overall success of every contributor.

In its new vision and strategy, CIMMYT makes a major commitment to assisting in the overall coordination of the value chains in which it operates – to the extent of ensuring that all essential components are equally active and that all linkages are fully functional. Accordingly, CIMMYT structured its research programs to meet local needs with six thematic programs to catalyze interdisciplinary research done in collaboration with a broad range of partners. The programs were designed to maintain a clear focus on livelihoods and production systems rather than on commodities or disciplines. In this way, the new organizational structure reflected the commitment to implement research as integratively as possible and considering the different natural, economic, and cultural factors determining where and how maize and wheat are grown, marketed, and consumed. However, more recently some flaws have been highlighted in the CIMMYT strategy that led to the recommendation that the center should pursue a business plan development process (CGIAR, 2005c).

Creating a business plan forces a very different set of introspections compared with defining a vision and strategy based on a generic value-chain framework. Interestingly, in defining the operational details underlying the vision and strategy, it was realized that it was more important for organizational structure to directly respond to the demands of the operational plan than to symbolically give weight to the vision. In this context it seemed clear that the interdisciplinary organization structure needed to be commodity-based (product-driven) as opposed to ecoregionally based (client-driven). That is not to erode the influence of client-driven priority setting but simply acknowledging a tactical operational reality. This is also to some extent a reflection of the Science Council's strategy for centers such as CIMMYT to draw away from finished product development and to increasingly focus on more upstream IPG. Although, of course, all the while maintaining a strong value chain perspective to all aspects of their work. This is an important insight into the consequences, both in terms of duration of transition and transactional cost, of dramatic changes in the agenda. Nevertheless, the business plan process provided a valuable opportunity to focus on defining comparative advantage niches around which to define the hard structure of the organization. However, CIMMYT acknowledges that pressures to make substantial agenda changes are an increasingly frequent event. For this reason, the soft structure of the organization has been designed to be incredibly flexible and easily changed.

After launching the “Seeds of Innovation” vision and strategy, the ecoregional programs were CIMMYT's implementation units and served as the basis for working out a conclusive, prioritized research agenda in consultation with stakeholders. The ecoregional consultations allowed CIMMYT to define priority investments that should result in innovations such as genetically enhanced seed-embedded technologies or conservation agriculture to sustain African livelihoods. Other priority areas included managing risk in rain-fed wheat systems of West and Central Asia and North Africa, better income options in high-potential areas of the intensive maize and wheat agro-ecosystems, particularly

in South Asia, China, or Mexico, and conserving natural resources in maize tropical ecosystems while improving the human well-being of the inhabitants of Latin America and East Asia. These operational frameworks remain as important now as they were during the last 2 years, except they are now implemented in practice at the project level rather than symbolically through the organization structure. Needless to say, in institutional cultural change terms, it was critical to have passed through this intermediate institutional structure phase, as it would probably have been too difficult to make the same transition in operational mindset by a single direct step. Again, it is critical when restructuring the institutional agenda to bear in mind the plasticity of the current organizational mindset if the change initiative is to be rapid, effective, and sustainable.

Establishing a trait-based operational framework is also the only feasible option for ensuring effective integration of new technology innovations resulting from reductionist research in biotechnology and bioinformatics. However, the critical challenge for such a structure is to ensure that priority setting and review of outputs is carried out in an end-user perspective with the context of the target product. Equally important, of course, is ensuring that downstream feedback also influences the agenda of those ARIs that are very often key providers of upstream technologies. In essence, this is all a question of fully and comprehensively defining the value chain, within which we are working, and then ensuring an intensive and iterative dialogue amongst all members during priority setting, project planning, and review. One mechanism to ensure the effectiveness of this process is currently being pilot-tested by CIMMYT through the launch of trait-based global initiatives, coordinated by CIMMYT but with equal input from and empowerment of all members across the value chain towards collective priority setting, fund raising, and project implementation. These global stakeholder initiatives effectively serve many of CIMMYT's projects, guiding priority setting, fund raising, project implementation, and product delivery. For other projects, entities are emerging or are already in existence that can provide a similar multidisciplinary multiinstitutional framework.

To facilitate the management of the projects, the Business Plan clusters the projects under two commodity pillars (Global Maize and Wheat Programs) and two thematic support units (Genetic Resources and Enhancement, and, Impacts, Targeting and Assessment). Such organization of the research agenda preserves the conceptual framework of "Seeds of Innovation" in which CIMMYT research-for-development uses the continuum formed by two kinds of livelihoods systems: those in which maize and wheat are the staple food of rural households and others in which maize and wheat should generate income, foster economic growth and alleviate poverty. An overarching philosophy for all projects is to establish intimate and iterative linkages to the other projects through a trait-based framework.

In summary, the Business Plan 2006–2010 describes how CIMMYT operationalizes the agenda it defined through widespread consultation in its "Seeds of Innovation" vision and strategy document. Through eight impact-oriented

Projects, CIMMYT will create maize and wheat technologies that foster both poverty reduction and food security, while contributing to resource conservation and sustainable development. The process by which the Business Plan was crafted involved both the Board of Trustees and Center staff and a diverse cross section of stakeholders – so it was at the same time bottom-up, top-down, and highly consultative. It reflects input from development investors and partners, as well as other stakeholders, provided through the participatory process that led to “Seeds of Innovation”.

THE ROLE OF THE PRIVATE SECTOR AND THE IMPORTANCE OF INTELLECTUAL PROPERTY PLANNING

Another area needing special attention, especially in international public research organizations, refers to partnerships with the private sector, particularly at a time in which publicly funded research has declined by more than 50%. At the same time, the private sector has assumed an increasing share of agricultural research and ownership of new technologies. The emergence of global markets, biotechnology, and information and communication technologies have a strong influence in changing the strategic direction of agricultural research. However, the potential impact of these technologies has led to a huge emphasis on intellectual property (IP) protection of the outputs from investments in these areas, including by advanced research institutions in the public sector. In a liberalized economy, public and private sectors must therefore work together to promote economic growth with a shared interest to enhance markets for local and export trade, create more employment, and generate higher incomes. However, strategically we must be careful to define how much influence private sector interests may have in shaping the overall agenda. This relates to careful consideration of the implications of forming partnerships, accepting funding, and carefully investigating the IP scenarios associated with inputs to research projects.

The nature of public and private sector applied research and plant breeding is changing, with the public sector acquiring some of the characters of the private sector and the private sector performing some functions of the public sector. Meanwhile, we are firmly trapped in an era of declining public investments in agricultural research, which is most severe in near-to-market activities such as cultivar development. This is a global trend affecting both developed and developing countries. Public investment in germplasm enhancement can be readily justified because of the large spillover benefits to society. However, this is often not reflected in government policy. At the same time, the global excitement surrounding the genomics revolution creates substantial opportunities for private sector funding of biotech-assisted germplasm enhancement. Unfortunately, these usually involve some level of IP protection or confidentiality agreement that may constrain the development or distribution of products to stakeholders. In contrast, it is increasingly difficult to defend the use of public funds for the development, multiplication, and distribution of new cultivars, as these are

inherently private sector activities for many crops in most regions. Innovative approaches to technology swapping, material licensing, contract research, and even royalty payments all offer opportunities to counteract the effects of these trends, and providing they are carefully and strategically managed, the net long-term effect is likely to be beneficial.

Public–private partnerships depend on mechanisms that represent and give voice to both private sector interest for commercial profits, and public goals to share benefits for the society at large. Mechanisms should be sought to bring together government policymakers and private actors to establish a dialogue that leads to a shared vision of agriculture and rural development, which leads to a common agenda for agricultural research, and an appropriate division of labor and resources in joint ventures. However, the creation of effective public–private sector partnerships should be designed to liberate additional funds for neglected research areas that are core to the long-term sustainability and impact of germplasm enhancement. In particular, investments in long-term research projects that lack immediate financial gain. Yet this will lead to an increasing need for public sector breeding programs to protect their own germplasm so as to have some bargaining power with the large multinational companies (MNCs).

It is also important to appreciate the nonrevenue-based advantages of creating public–private sector partnerships. As the public sector develops a more commercially orientated relationship with the private sector, it will be concomitantly building a stronger relationship with entities that will be increasingly important for uptake of research outputs. These linkages will be important for translation and delivery of research outputs to poor-farmer constituencies as tangible impacts from investments in public sector agricultural research. If properly planned and managed, these relationships should evolve into a strong mutually beneficial collaboration between public and private sectors. And finally, beyond the financial gains for public breeding programs, some have long since argued that society at large (in both developed and developing worlds) will be best served by a nonmonopolistic mix of both private and public sector plant breeding (Simmonds, 1990; Innes, 1990). Moreover the time is well overdue that the medium to large private sector companies in well-developed commodity markets are coerced to return to the CGIAR some of the profit resulting from their free access to enhanced germplasm from the IARCs. However, this does not suggest that there should be any erosion of the “free-to-all” access to wild and unimproved germplasm (such as landraces). Although some level of cost recovery may need to be considered that has already been implemented at ICRISAT (discussed in detail below). Conversely, it will be increasingly seen as the CGIAR’s role to support the development of small private seed enterprises in countries where this is not readily occurring spontaneously. In these countries, the role in developing effective cultivar testing and release systems will be as important as it is already perceived to be for assisting the development of biosafety regulation systems for the introduction of transgenic crops. At the same time, the increasing tendency for patenting

plant cultivars (mostly so far related to transgenic lines) is driving a radical change of culture in the plant breeding business where monopolization will have a much more drastic effect than it would have done in an era where such cultivars were just protected by plant breeders' rights. In this context, widely available products of germplasm enhancement will be an important IPG of the CGIAR and one that development investors will hopefully consider to be an important use of public funds.

Counteracting the negative impacts of consolidation in the seed sector

There has been a steady fall in the number of public sector plant breeders and a dramatic increase in the number of private sector plant breeders. This is a global trend with substantial implications for training of the next generation of plant breeders and for the level of diversity maintained in our agricultural systems. The public sector must provide a major contribution to both these areas. By rebuilding critical mass in public plant breeding through innovative partnerships with the private sector, the CGIAR and NARS will be substantially more capable of offering in-depth training in plant breeding. This will positively contribute to the strength of plant breeding capacity in NARS, SME, and CGIAR breeding programs. It is also envisaged that this would allow a great focus on retaining genetic diversity in contemporary breeding pools. Thus, alliances with private sector plant breeding programs would be expected to lead to sharper focus and defined comparative advantage, more efficient breeding systems, more proactive promotion of products, adequate plant variety protection in target regions, and increased negotiating and legal skills.

By economic necessity MNCs focus more on crops and traits of importance to major high value regional production areas. There is a clear rank order that private sector investment follows; firstly, high value plants that are difficult to propagate on-farm – such as vegetables and fruits, secondly, hybrid crops (in view of the “biological protection system” for investors leading to a high probability of repeat sales) particularly where there is a premium for specific quality traits, and finally wheat, rice, maize (in view of having the top three production areas). Although commercial seed production has limited economies of scale, it does offer economies of scope, such that once a production and marketing system is in place for more profitable seed crops, other types of seed can be added. Unfortunately, emerging seed systems are also very easily destroyed, thus CGIAR centers have a crucial role to play in helping to design emergency seed programs in ways that do as little damage as possible. It is also necessary for public sector plant breeding to accept the critical role of strengthening SMEs so they can successfully deliver effective products in niche markets such as resource-poor cropping systems. In addition, consolidation threatens competition and innovation in plant breeding. By strengthening SMEs it should be possible to counteract this effect. At the same time, an increased proximity to SME breeding programs should result in an increased adoption of outputs from publicly

funded research. Thus, from all angles, it is increasingly clear that public plant breeding programs must build strong links with the private sector to ensure an appropriate product development and delivery pathway. However, the CGIAR must also take every available opportunity to counteract global trends that give preference to larger companies and thereby foster consolidation, in particular by fostering SME breeding programs. Although at present the situation is perhaps still relatively balanced. For example, in maize there appears to be a dominance of a small number of companies but in fact there is a sizable proportion of the market held by a large number of small regional companies, and a third portion is held by a smaller number of companies of intermediate size.

As we approach scenarios that are perceived to facilitate greater private sector influence, there is a critical need to introduce a substantially greater diversity of stakeholders into the decision-making process. Research through commodity associations works best where farmers control the level of funding and the research agenda. Although this will undoubtedly increase transaction costs, it should be argued (and actively pursued) that international development investors will welcome this move and in turn be rewarded by greater unrestricted funds allocation. There is no doubt that this mode of operation will require innovative and sometimes unique forms of collaboration. Inevitably this will require substantial efforts in the area of innovation policy development and advocacy. There is also a great need for the CGIAR as a whole, to help improve the cultivar testing, release, and protection systems in many developing countries. The inadequacy of these systems is holding back private sector investment.

Dealing with the indigenous private sector

As the public sector develops a more commercially orientated relationship with the private sector, it will be concomitantly building a stronger relationship with entities that will be increasingly important for uptake of public research outputs and for translation and delivery of these research outputs to poor-farmer constituencies as tangible impacts from investments in public sector agricultural research. If properly planned and managed, these relationships should evolve into a strong mutually beneficial collaboration between public and private sectors. In this regard, the 2001 International Treaty on Plant Genetic Resources for Food and Agriculture established a multilateral system of access to plant genetic resources (PGR) and benefit sharing arising from the use, including commercial, of those PGR included in this multilateral system (FAO, 2004). In its article 13d, the International Treaty refers to sharing of monetary and other benefits of commercialization, which is activated when someone acquires material from the multilateral system, incorporates it into a product that is a PGR, commercializes it, and then protects it in a way that restricts subsequent access and use of the product. In practice, if someone takes a utility patent on the product, benefit-sharing will be required, where if one takes out plant breeders rights,

benefit sharing will not be required, as this form of IPR (intellectual property rights) explicitly allows the protected cultivar to be used for further research and breeding (Fowler and Lower, 2005).

Some level of cost sharing may also need to be considered as has been implemented since 2000 by the International Crops Research Institute for the Semi-Arid Tropics (ICRISAT) with the private seed sector in India through their crop improvement consortia. The defining framework of ICRISAT's research and breeding consortia is that although consortium members contribute a modest amount of funding, the products are all freely available to all. That this approach can work has been demonstrated in pearl millet, pigeon pea, and sorghum where the private sector consortium members fund a substantial portion of the costs of ICRISAT's core research and breeding agenda for India. All materials ensuing from this public-private partnership are freely available to public sector through the use of a material transfer agreement. (MTA) The consortia' agreements facilitate improved use of ICRISAT-bred germplasm by the private sector, which in India are the most important delivery agents for improved germplasm in these crops. ICRISAT applies a rolling scale of charges based on the amount of investment they have made in that material. The work plan of each crop-breeding consortium is approved by their respective Advisory Committee, which serves for a 2-year term, and consists of three professionals drawn from the private sector members, two from ICRISAT staff, and one from the Indian Council of Agricultural Research representing the national public sector.

OPTIONS AND RECOMMENDATIONS

This chapter advocates a participatory, all-inclusive bottom-up approach, and warns us of the shortcomings of selective, exclusive top-down setting of the research agenda. However, rarely do the outputs of diverse consultation result in a unanimous consensus. Once all the input is on the table it is only an institution's management team who can effectively assimilate all the data and create a rational and coherent agenda that offers the best compromise between what is needed, what can be funded, and what is the institutions comparative strength to implement.

In recent years lobby groups have stood against biotechnology using inflammatory arguments. Whether the statements are truthful or not is clearly beyond the scope of this book. However, there is no doubt that such bioethic issues must also be addressed by both managers and scientists as they finalize the research agenda of their organization. Voluntary codes of self-regulation for this kind of research are not enough since as activists point out, scientists cannot be allowed to act both as judge and jury². Society should agree therefore on appropriate regulatory and evaluation frameworks for such research undertakings to ensure a working environment in which the facts of Science and its positive impact on

² <http://www.etcgroup.org/article.asp?newsid=562>

livelihoods can prevail. Clearly there is little consensus across regions, governments, and societies regarding these issues. Thus, we would argue that it is the duty of agricultural scientists to provide a variety of options from which market forces and social judgments can make their own choices. Not to do so would be forcing our own personal moral frameworks on the agenda of our institutions.

REFERENCES

- Alston, J.M., Norton, G.W., and Pardey, P.G. 1994. *Science under Scarcity: Principles and Practice of Agricultural Research Evaluation and Priority Setting*. Cornell University Press, Ithaca, NY.
- CGIAR. 2005a. *System Priorities for CGIAR Research 2005–2015*. Science Council Secretariat, Food and Agriculture Organization of the United Nations, Rome, Italy.
- CGIAR. 2005b. *Guidelines for External Program and Management Reviews (EPMR) of the CGIAR Centers*. Science Council Secretariat, Food and Agriculture Organization of the United Nations, Rome, Italy.
- CGIAR. 2005c. *Report of the Fifth External Programme and Management Review of the Centro Internacional de Mejoramiento de Maíz y Trigo (CIMMYT)*. Science Council Secretariat, Food and Agriculture Organization of the United Nations, Rome, Italy.
- CGIAR TAC. 1998. *CGIAR in Latin America and the Caribbean: Interactions, Achievements and Prospects*. Technical Advisory Committee, Food and Agriculture Organization of the United Nations, Rome, Italy.
- CGIAR TAC. 2001 *Report of the Fifth External Programme and Management Review of the Institute of Tropical Agriculture (IITA)*. Technical Advisory Committee, Food and Agriculture Organization of the United Nations, p. 56, Rome, Italy.
- CIMMYT. 2003. *Seeds of Innovation*. Centro Internacional de Mejoramiento de Maíz y Trigo, El Batán, Mexico.
- CIMMYT. 2005. *CIMMYT Business Plan 2006–2010 – Translating the Vision of Seeds of Innovation into a Vibrant Work Plan*. Centro Internacional de Mejoramiento de Maíz y Trigo, El Batán, Mexico. http://www.cimmyt.org/english/docs/mtp/bp06_10.pdf
- Collinson, M., and Tollens, E. 1994. The impact of the international agricultural research centers: measurement, quantification and interpretation. *Issues in Agriculture* 6. Consultative Group on International Agricultural Research, Washington, DC.
- Cooke, P., Kaufmann, D., Levin, C., and Wilson, R. 2006. The biosciences knowledge value chain and comparative incubator models. *Journal of Technology Transfer* 31:115–129.
- De Janvry, A., and Kassam, A.H. 2004. Towards a regional approach to research for the CGIAR and its partners. *Experimental Agriculture* 40:159–178.
- Dixon, A.G.O., Bandyopadhyay, R., Coyne, D., Ferguson, M., Ferris, R.S.B., Hanna, R., Hughes, J., Ingelbrecht, I., Legg, J., Mahungu, N., Manyong, V., Mowbray, D., Neuenschwander, P., Whyte, J., Hartmann, P., and Ortiz, R. 2003. Cassava: from poor farmer's crop to pacesetter of African rural development. *Chronica Horticulturae* 43:8–15.
- Douthwaite B., and Ortiz, R. 2001. Technology exchange. *Electronic J. Biotechnology*, 4(2) <http://ejb.ucv.cl/content/issues/02/index.html>
- FAO. 2004. *The International Treaty on Plant Genetic Resources for Food and Agriculture*. Food and Agriculture Organization of the United Nations, Rome, Italy.
- FARA. 2004. *Annual Report 2003*. Forum for Agricultural Research in Africa, Accra.
- FONTAGRO. 2004. *Plan de Mediano Plazo 2005–2010*. Fondo Regional de Tecnología Agropecuaria, Washington DC.
- Fowler, C., and Lower, R.L. 2005. Politics of plant breeding. *Plant Breed. Rev.*, 25:21–88.
- GFAR (2001) GFAR Contribution to the EFARD proposal for the elaboration of the 6th Framework Programme of the European Union. In Annex II *2nd EFARD General Meeting on "Strengthening the European Contribution."* European Forum on Agricultural Research for Development, Rome, Italy.
- GFAR. 2004. *Annual Report 2003*. Global Forum on Agricultural Research, Rome.

- Hartmann, P. 2004. *An Approach to Hunger and Poverty Reduction for Sub-Saharan Africa*. International Institute of Tropical Agriculture, Ibadan, Nigeria.
- Hartwich, F. 1998. A cumulative indicator for measuring agricultural research performance: accumulating performance measures of agricultural research operations in a developing country. *ISNAR Discussion Paper* 98-1. International Service for National Agricultural Research. The Hague, The Netherlands.
- Hartwich, F., and van den Akker, E. 2000. Priority setting in agricultural research project planning. In: Graef, F., Lawrence P., and von Oppen, M. (eds.) *Adapted Farming in West Africa: Issues, Potentials and Perspectives*. pp. 391-398, Verlag Ulrich E. Grauer, Stuttgart, Germany.
- Innes, N.L. 1990. Plant breeding and intellectual property rights. In: Müller, R.A.E. (compiler) *Workshop on Consequences of Intellectual Property Rights for the International Agricultural Research Centers*. International Crops Research Institute for the Semi-Arid Tropics (ICRISAT), Hyderabad, India, 19-21 November 1990. Christian Albrechts Universität zu Kiel, Germany. <http://www.agric-econ.uni-kiel.de/Abteilungen/II/forschung/file5.pdf>
- Kassam, A.H., Gregersen, H.M., Ferreres, E., Javier, E.Q., Harwood, R.R., de Janvry, A., and Cernea, M.M. 2004. A framework for enhancing and guarding the relevance and quality of science: the case of the CGIAR. *Experimental Agriculture* 40:1-21.
- Maredia, M.K., and Raitzer, D.A. 2006. *CGIAR and NARS Partners Research in Africa: Evidence of Impact to Date*. Science Council Secretariat, Food and Agriculture Organization of the United Nations, Rome, Italy.
- Mills, B. 1998. *Agricultural Research Priority Setting: Information Investments for the Improved Use of Research Resources*. International Service for National Agricultural Research. The Hague, The Netherlands.
- Nameroff, T. 1997. Setting the agenda for U.S. science and technology policy. *CSA Today* 7:11-12.
- Neuenschwander, P. 2004. Harnessing nature in Africa: biological pest control can benefit the pocket, health and the environment. *Nature* 432:801-802.
- Ortiz, R. 2005. *IITA 40 Years After*. Board of Trustees Docket. International Institute of Tropical Agriculture, Ibadan, Nigeria.
- Ortiz, R., Bramel-Cox, P.J., Hash, C.T., Mallikarjuna, N., Reddy, D.V.R., Seetharama, N., Sharma, H.C., Sharma, K.K., Sivaramakrishnan, S., Thakur, R.P., and Winslow, M.D. 1999. Potential for Improving Agricultural Production through Biotechnology in the Semi-Arid Tropics. *Water Commission on Dams Thematic Reviews IV. 2 - Assessment of Irrigation Options*. <http://www.dams.org/docs/kbase/contrib/env092.pdf>
- Ortiz, R., and Crouch, J.H. 2004. *The CGIAR at 33: An Urgent Call for Change to a Renewed Relevance*. Kampala, Uganda. (mimeo).
- Ortiz, R., and Hartmann P. 2003. Beyond crop technology: The challenge for African rural development. In Vol. 2. *Reference Material of the Sub-Saharan Africa Challenge Program "Building Livelihoods through Integrated Agricultural Research for Development - Securing the Future for Africa's Children"*. pp. 39-72. Forum for Agricultural Research in Africa (FARA), Accra, Ghana.
- Ortiz, R., Mowbray, D., Dowswell, C., and Rajaram, S. 2007. Dedication Norman E. Borlaug: The humanitarian plant scientist who changed the world. *Plant Breeding Reviews* 28: 1-37.
- Ryan, J. 2006. *International Public Goods and the CGIAR Niche in the R for D Continuum: Operationalising Concepts*. Science Council Secretariat, Food and Agriculture Organization of the United Nations, Rome, Italy. http://www.sciencecouncil.cgiar.org/meetings/meeting/SC5/Item_13_IPGs_&_R-D_Continuum.pdf
- Shah, M., and Strong, M. 1999. *Food in the 21st Century: From Science to Sustainable Agriculture*. CGIAR System Review Secretariat, The World Bank, Washington DC.
- Simmonds, N.W. 1990. The social context of plant breeding. *Plant Breeding Abstracts* 60:337-341.
- Singh, B.B., Hartmann, P., Fatokun, C., Tamo, M., Tarawali, S., and Ortiz, R. 2003. Recent progress on cowpea improvement. *Chronica Horticulturae* 43 (2): 8-12.
- Sumberg, J. and Reece D. 2004. Agricultural research through a "new product development" lens. *Experimental Agriculture* 40:295-314.
- Von Oppen M. and Ryan J.G. 1985. Research resource allocation: determining regional priorities. *Food Policy* 10:253-264.

CHAPTER 5

THE RESEARCH DEPARTMENT AND INSTITUTE

SHLOMO NAVARRO AND GAD LOEBENSTEIN

Agricultural Research Organization, Volcani Center, Bet Dagan 50-250, Israel

THE RESEARCH DEPARTMENT

The researcher with his/her team of technician(s) forms the basic unit of a research department. Often a researcher with professional and managerial skills of leadership forms a working group, on a specific range of projects integrated within a general concept. Researchers or research groups operate within a department.

Departments can be organized according to scientific disciplines (discipline-oriented departments), such as genetics, plant pathology or post harvest physiology, or types of production (product-oriented departments) such as animal husbandry, vegetable crops, fruit crops, etc. In both cases the common background of the researchers and their fields of research forms the basis for cooperation among them that often results in interaction in projects, exchange of ideas, and better use of technology needed for the realization of the projects. Often within a team of researchers in a department, there are researchers with different expertises, skills, and approaches that complement each other, which are essential to advance the projects. For example, within a department of Plant Virology it is advisable to have an entomologist for work with insect vectors, a molecular biologist for cloning and transformation, an electron microscopist (if an electron microscope is available mainly for the department), a serologist for developing identification methods based on serology, and a tissue culture specialist for obtaining virus-tested plants and transformation. However, often, budgetary constraints limit the number of scientific personnel. Therefore, it is often necessary for a researcher to have more than one obligation. Thus, for example, the scientist with a specific expertise (virologist, phytopathologist, or entomologist) should also have the responsibility for a certain group of crops, or in a production department the scientist will have to deal with more than one crop. In each case it is advisable that each researcher has his/her job description, but allowing him/her sufficient

time (about a third to a quarter of his obligations within the department) to pursue research according to his own wish and professional interest. This is similar to the obligations in a university department, where each staff member has a teaching obligation and a research area, which is generally only broadly defined.

The size of a department is determined by the needs of the farming community, government budget allocations, available grants, and history of the department. Often the permanent staff is small but due to sudden needs and problems, successes in grant approvals and students who come with their own grants, it may increase several times more than the number of the permanent staff.

Presence of students in the department are a major asset. While in university department's students are the norm, an effort should be made in a research institute to attract students – for M.Sc. and Ph.D. degrees as well as postdoctoral students. This can be done by a liaison agreement between the Institute and a University, fellowships and good facilities for the students. The presence of students in the department creates a lively atmosphere, opens new vistas and ideas, forces the research staff to keep up with the literature, and often brings new technologies to the department.

It is advisable to locate all the researchers of the department together and not to spread them out in different buildings. This is imperative for having better communications between members and efficient use of equipment.

The department provides common services to the researchers such as greenhouse maintenance, culture rooms for insects, acquisition of expensive equipment, and media preparation.

Technicians

Qualified technicians are most important for the good functioning of the research and the department. They participate not only in the good execution of the research and data recording, but might also be involved in the planning of the experiments. Once they consider themselves as part of the team, their motivation, involvement, and observations of the results will increase markedly and they often will see details that did not come to the attention of the researcher. The researcher will do well if he listens to the suggestion of his/her technician. When the technician actively participates in the planning and/or makes significant contributions to the research it is advisable to add his/her name as an author in the publication. It is advisable to employ technicians who have a good training, preferably with a B.Sc. or even a Masters degree. It is also of advantage if the technician advances his/her knowledge by attending courses, seminars, and even working on a more advanced degree.

COMMUNICATION IN THE DEPARTMENT

Good communication among the research staff within the department is of utmost importance for its smooth functioning. Timely seminars and journal clubs, and discussions of the ongoing and future research projects achieve this. Staff members and students should give seminars, both on their own research projects, as well as on new “hot” topics in science. Leading scientists from other institutions and universities should also be invited, and guest scientists should be encouraged to present their research.

An extremely important tool for discussing current issues related to the interest of all department staff is the periodic department staff meeting. These meetings may be maintained on a biweekly or monthly basis. This is the forum where administrative announcements are made and routine operational rules are discussed. These meetings may be held in the presence of researchers only, or in the presence of the technical and research staff together. In addition, at least once a year researchers should discuss the way that the department operates and what research directions should be encouraged or deleted. Discussions of proposals for acquiring joint and/or major items of equipment are also encouraged. It is highly recommended that researchers and technicians meet once a day for an informal coffee break, where all kinds of topics (and gossip) are brought up. Some departments make the rule of meeting at the last day of the week where social and personal issues are discussed in an informal and friendly atmosphere. Such meetings foster better communication among the staff and are imperative for the operation of the department.

Allocation of facilities

It is the responsibility of the department to allocate technicians, rooms and greenhouse space and decide how departmental funds should be spent. The acquisition of new equipment has to be discussed by the staff members of the department.

The head of the department

The head of the department should be an outstanding scientist, with broad general knowledge of the department’s research area, up to date with recent scientific literature, familiar with the agricultural system, and with an aptitude for administration and personal qualifications for leadership. He/she should innovative and raise novel ideas and approaches that could contribute to the advancement of the department’s science. The head of the department should encourage and help his scientists to submit grant applications. He/she has to be open to the other voices and willing to hear constructive criticism. He/she should meet informally with every researcher and technician to discuss the advancement of the research, giving every person in the department the possibility to express their opinions.

While he is the “head” of the department he has to realize that research cannot be directed in the usual sense, and that the individual researcher is largely the manager of his own project. As the contact between the head and his researchers is extremely close, the conflict of interest between his responsibilities to management on one hand, and the ingrained antipathy of the researchers to management on the other hand, might give rise to strains and stresses. It is only when the department head is also the recognized leader in the field that a workable relationship can be established and maintained. To maintain this position the department head must also be actively and personally involved in research and up to date with the literature, and simultaneously devote a considerable amount of his time to contacts with his researchers (Arnon, 1968).

The head of the department should be sufficiently knowledgeable in the department’s particular field of research to provide guidance to the researchers in the department. He/she should feel comfortable of sharing his ideas with the researchers in the department. He/she should not fear competition and should not compete with other researchers in the department for funds or new proposals. On the contrary he/she should promote collaboration and whenever possible he/she should create the infrastructure for enhancing cooperation among the researchers within his department and with researchers from closely related departments. The head of the department should aim for cooperation among researchers to achieve interaction that enhances achievements beyond the additive results of two independent researchers. By learning the specific skills of each researcher, the head of the department should be in the capacity to identify who, and on which subject cooperation of one or more researcher, can bring synergism in productivity. Furthermore, his/her leadership should expand beyond the existing research objectives and be able to develop a visionary approach for future developments and novel technologies. A department head without vision remains as an administrative manager. The success of a department to carry out good quality research in harmony is often dependent on the leadership and authority of the department head.

There are several systems for selecting and appointing department heads. In the conservative system, still practiced in some countries, selection and appointments are the prerogative of the administration, which may or may not consult with the researchers of the department. The worst cases are in countries where appointment to head of department is viewed as a political promotion. On the other extreme, researchers in the department select and elect their head. Sometimes selection committees, where administration and researchers from the department and from other institution participate (and in some instances with farmer’s representative), may evaluate candidates from within or from outside the department for the position. In such a case it is advisable that the search committee recommends more than one candidate for the final decision of the administrator. Another possibility is that the head of the organization selects a candidate for approval by the department’s council of the researchers.

The term of office also varies in different institutions. In some of the conservative European research or University departments appointments may be for life. It is however of advantage if the term of office is limited to 3–4 years, with an option for a second term. This seems to be preferable as it gives the opportunity for other/new ideas to be applied in managing the department.

Budgets and funds

The available budget is greatly dependent on the proportion of the national budget devoted to agricultural research and development. As the total national budget for agricultural research increases, the portion to the specific department may also increase. The budget in a specific department may not be the result of a proportional distribution of the available budget within an institute. The budget may greatly be dependent on the convincing activities of the head of department to justify specific expenses. For example, the purchase of scientific equipment (mass spectrophotometer, high resolution electron microscope) that the department is the principal user within the research institute may be initiated and purchased by the institute using the budget of the institute, while the principal beneficiary is the department that initiates the purchase.

A very common issue is the mobilization of funds for the department. In some countries the government allocates in its budget funds necessary for research in various fields of science. Wealthy or high GNP countries where the national priorities for research are set, dictated, and influenced by the government policy on R&D generally adopt this centralized approach. Such approach in low GNP countries may be a serious barrier that necessitates a serious shift into a decentralized policy that would allow the researcher an independent stand to the mobilization of funds. In some countries funds are mobilized by farmers' organizations or agricultural chamber of commerce. These funds are made available to agricultural research through various national instruments developed generally within the ministry of agriculture. To benefit these national funds greatly depends on the activity of the head of department in close collaboration with the researchers of the same department.

An additional significant source for mobilizing funds is through international cooperation. The capacity of the researchers to cooperate for mobilizing such research grants necessitates the encouragement by the head of department to participate in these programs for international cooperation. In this respect, the availability of funds for research within the European Union (EU) development programs, binational or multinational cooperation programs is worth mentioning. These programs are directed to foster collaboration among researchers of various countries. On the other hand preparation of proposals for some programs, for example, to the instruments developed within the EU, is not only tedious effort but also necessitates a professional support from specialized companies. In this aspect, the stand of the head of department has an important influence on encouraging or discouraging the researchers to devote

a considerably portion of their time to the preparation of proposals. A careful planning at departmental level by the head of department in collaboration with the researchers is necessary.

In some organizations the policy to the mobilization of funds is a concentrated activity by the head of department in cooperation with researchers to identify the available appropriate funding sources. In other organizations each researcher is responsible for mobilizing his funds for research. The role of the head of department is less pronounced. There are advantages and disadvantages of each of these approaches. In departments where researchers have developed strong scientific leadership, mobilization of funds is possible without the concentrated efforts of the head of department. Whereas, in departments with young and not sufficiently experienced researchers, concentrated efforts in collaboration with the head of department, should be preferable.

The department should have in addition to the permanent staff and technical positions a core budget. This budget should be at the disposal and discretion of the department's head. The size of this budget should be large enough to serve as seed money for testing new ideas and getting first results to enable the preparation of a proposal for a granting agency. This budget might also be used as a part of the cost for new departmental equipment.

In cases where the core budget of the department is not sufficient to cover common expenses for maintenance and equipment it may be necessary to levy a certain percentage on grants as departmental overhead.

University departments

The main obligation in university departments is teaching. The department is responsible for compiling the teaching curriculum and its smooth operation. This requires selection of courses and teachers, allocation of graduate students for technical help in laboratory classes and help in grading examinations, and the necessary equipment for teaching as projecting and laboratory equipment. In some universities the department also has responsibilities for the research agenda, while in others the staff within their academic freedom selects their subject for research.

THE RESEARCH INSTITUTE

In large research organizations, with numerous research areas and units, it is generally the norm to group departments around a certain subject into an Institute. This facilitates communication between the central administration and the departments, enables acquisition of joint equipment, may enable inter-departmental research, and provide services, which the separate departments cannot afford.

Thus, in an Institute of Plant Science there might be departments of Horticulture (fruit trees, vegetables, ornamentals), Agronomy (field crops, pasture, medicinal and aromatic plants, industrial crops), Genetics, Physiology, and Nitrogen fixation.

An Institute for Plant Protection may have departments of Entomology, Plant Pathology and Virology, Nematology, and Weed research.

While the research is carried out within the departments the Institute provides administrative and certain other services (maintenance, transport) and organizes seminars.

HEAD OF THE INSTITUTE

The head of an institute should be a very senior scientist, preferably one who served as head of department before. The head of the Institute coordinates work between the departments; initiates research teams, also with research groups from other institutes and solves personnel and other problems.

A common problem often encountered in a research department or institute is the conflict of interests that may derive from the increasing success of a researcher and the envy developed by the less successful researcher/s. This human behavior involving emotional responses, in many cases serves as the driving force for the conflicting decisions or for the way the department or the institute is managed. This human response should by no means be underestimated and dealt with maximum objectivity by the head of department or institute. They should be constantly on alert to spot and timely identify such conflicts that have disastrous consequences accompanied by the resignation or dismissal of gifted personnel. The head of department or institute should be as objective as possible in such cases. A biased stand never brings a solution to the problem. In extreme cases consultation of an industrial psychologist is most advisable. The head of department and the institute should closely collaborate at the initial stages to identify such conflicts as soon as possible to create a favorable atmosphere to prevent its expansion as early as possible. They should be aware that such conflicts are not evident and not easily identified; they remain hidden deep in the soul of the involved researchers. It necessitates a constant surveillance by both head of department and institute. Discovery of such conflicts at later stages, when they become obvious to all, might be much more difficult to solve, and in most cases they may lead to detrimental and nonrational actions.

The head of the institute serves as a liaison between the central administration of the organization and his/her departments. In many cases he/she should be a member of the directorate of the organization. The head of the institute is a member of various committees of the organization and others, where his/her knowledge of the various disciplines of the institute is required. One of these will be the one that deals with staff promotions. The head of the institute should coordinate work between the departments; initiate establishment of new research teams, and promote collaboration among them and with research groups from other institutes, and solve personnel and other problems.

The head of the institute should be involved in the reviewing process of the research results of the members of the institute, and point out both the strength and weaknesses of the performed research.

As to his/her appointment various procedures exist in different institutions similar to those outlined for department heads. It is advisable to appoint him/her for a term of 4–5 years, with the option of another term, though in the Max Planck organization in Germany heads of institutes are often appointed for life (until retirement).

The head of the institute is responsible for organizing and updating the research plan of his/her departments, including budget requirements. It is advisable that he/she has at his discretion an operating budget to encourage new research areas and proposals as seed money until grant applications can be prepared and are funded. This budget may be used at the initial stages of integrating a new researcher in the institute or for encouraging specific pioneering research upon the decision of the institute directorate. He/she together with the head of the relevant department has to approve and sign research proposals and subsequent reports. The head of the institute has an important say when new positions are allocated. He/she is also responsible for the smooth functioning of the institutes' administration. Often in order to relieve the departments of administrative burdens, the bookkeeping of the research budgets, personnel files, ordering of materials, and maintenance works, etc. is handled by the administrative staff of the institute.

The head of the institute should initiate "brainstorming" session on the main research issues concerning his institute. Such sessions could be fruitful for bringing up future research approaches, directions, and areas of potential importance.

REVIEW BOARDS

In many organizations it is common to review the activities and the objectives of departments or institutes every 4–6 years by examining their performance. The review board may consist of external and internal scientists, extension specialists and growers, and representatives of the central administration. It is of importance that the department (institute) prepares a detailed description of the research projects, including materials and methods, achievements, and constraints, and problems encountered during the review period of time. The performance of research leaders and senior scientists should also be reviewed and they should present an oral description of their work including plans for future developments. This is also an opportunity to air administrative and other personnel problems. The chairman of the committee following the review has to write a report, based on the panel's impressions and findings, evaluating the achievements and problems of the department (institute). This report should include recommendations to the central administration of the organization. It is obvious that such review panels have to be budgeted for travel expenses and lodging.

REFERENCES

- Arnon, I. 1968. *Organisation and Administration of Agricultural Research*. Elsevier Publishing Company Ltd., Amsterdam.

CHAPTER 6

LEADERSHIP IN AGRICULTURAL RESEARCH MANAGEMENT

JACQUELINE D'ARROS HUGHES

AVRDC – World Vegetable Centre, PO Box 42, Shanhua, Tainan 74199, Taiwan

WHAT IS LEADERSHIP?

Leadership is the ability to give focus and vision to others, clearly identifying goals to which others also aspire, thus increasing productivity, efficiency, and impact. Leadership functions at different levels and in different capacities. It is different from management or administration. It is visionary, but also has to be practical, and it operates at many different levels within organisations. Leadership of small numbers of people can be as important as leading many hundreds or thousands of people. In fact, the leadership of a large or complex organisation cannot usually function well unless there are other leaders at a lower level able to implement the leader's vision by leading smaller groups of people towards common goals.

Leadership is often confused with management, and sometimes with administration. The three often function together, although leaders should, to some extent, be able to distance themselves from the daily routine that involves management and administration. They are therefore able to devote more time to their leadership role. However they must be aware of, if not involved with, the critical managerial and administrative decisions. Leadership is most often associated with strategic decision-making, whereas management is essential for ensuring the vision of the leader can be achieved. Management is more often associated with tactical decision-making. Management assures the leadership that the capacity to reach the goals is available, that the human and physical resources are sufficient, and that the organisation functions effectively. Administration has a more mundane albeit very important role. Administration ensures effective operational decision-making; to ensure the day-to-day operations are in place and efficient. Administration has the responsibility for the working environment, financial records, personnel issues and activities necessary to keep an organisation running efficiently.

Leadership needs to be visionary, but also needs to be grounded in the current reality of the organisation. It reflects the personality of the leader. Global leaders articulate, and confer, the overall vision of an organisation. This vision may be derived from a consensus with others, or it can also be the leader's own vision, which he or she feels is apposite. A person, whose ideas do not address current needs and who cannot visualise and address emerging needs, cannot be an effective leader. A charismatic personality advocating goals that are inappropriate will not succeed. On the other hand, even the most idealistic vision from an uninspiring leader cannot hope to be reached unless another leader espouses the same goals and drives the vision forward.

There are many different levels of leadership, but there must be an overall leader in any organisation. The organisation may be global, continental, or national, but the need for leadership will be as important regardless of the size of the organisation. Agricultural research is no different from any other organisation or system. It too requires strong and effective leadership to be effective. If the organisation is decentralised, there must be leaders at each individual centre, institution, or location. Within any particular institution there is often a partitioning of research activities into programs or themes with leaders (who may be known by other titles such as coordinator, moderator or director), and within those subgroupings the individual projects must have leaders. It is important to remember, even if we take research down to the field level, leadership is critical. Leadership of technical or service staff of labour has a significant effect on productivity and efficiency, although the impact of leadership at these levels can be reduced through efficient and effective management and administration at higher levels.

Some people are natural leaders. When a natural leader articulates a vision or an idea, many people will follow that leadership through a combination of the leader's charisma, the vision that resounds personally with the people, respect for the leader, and belief in the goals and the vision. Some people are not born with leadership skills, but these can be learned and their skills improved over time. Even though leadership skills can be learned and developed, in many cases the leader who has acquired these skills through his or her career may always have to work a little harder than a natural leader to ensure that his or her vision is reached.

WHY DOES AGRICULTURAL RESEARCH MANAGEMENT NEED LEADERSHIP?

A diverse spectrum of organisations and institutions around the world do agricultural research. Coordinating their activities to deal with both local and global issues requires real leadership. Formal agricultural research is done by universities, national research institutions, independent research organisations, the private sector, and by international agricultural research centres. Additionally,

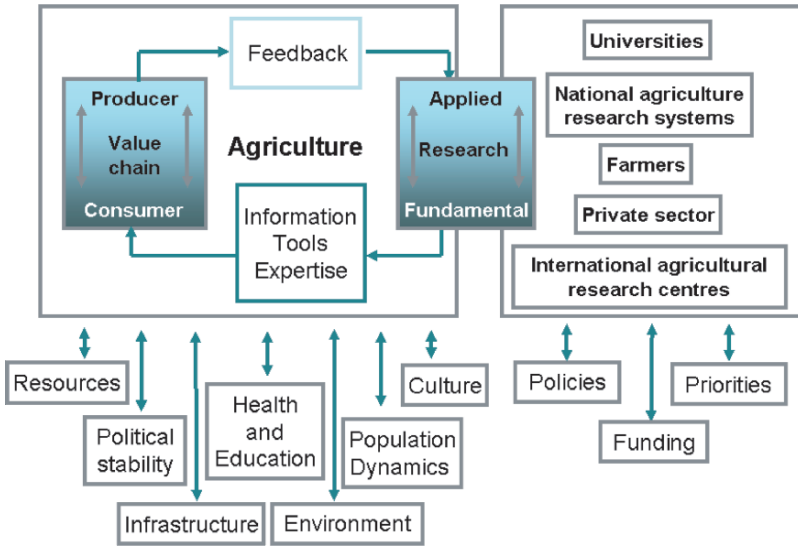

Figure 1. Complexity in agricultural research and the interactions that have to be orchestrated to ensure visionary leaders for agricultural research management. (see Color Plate 2 following p. xiv.)

some farmers have always done informal agricultural research in their own fields. This aspect is an important part of the research–development continuum. Coordination between all of these, to reduce duplication and achieve maximum efficiency from limited resources is not a simple task (Fig. 1).

This is starting to be addressed through multicentre, multi-institution or multi-organisation teams addressing common issues. Unfortunately this also exacerbates friction due to the idiosyncrasies of particular institutions or organisations, which may be linked to political or national concerns, to different leadership or vision, or simply to the issue of resource availability.

There are many potential areas of disconnect within research which require leadership to overcome. There is the potential disconnect between issues which need to be addressed and the research required to provide the information or tools to tackle the issues. There may be a geographic disconnect (which is often considered less of a problem in this more “virtual” environment but is real nonetheless), or between the disciplines participating in the problem-solving agricultural research, or a cultural/social disconnect. There may also be significant time lags between completing the necessary research and when decisions need to be made. These time lags also result in disconnects. Of perhaps more concern is the potential disconnect between basic and applied research, which is often compounded by institutional or geographic distance. Many universities are concerned with basic agricultural research that is conducted with the aim of obtaining knowledge – to obtain theoretical truths and to contribute to

mankind's knowledge and development. Universities have in the past had relative freedom to do this although at present with financial constraints it is progressively more difficult in some subjects to access the resources to continue basic research. In agriculture, basic research is an important starting point for much applied research, which is concerned with specific and defined problems rather than fundamental issues. Leadership is required to guide or lead the diversity of organisations and institutions performing research along this upstream, fundamental research to downstream, more applied research continuum (and often performing a development/extension function as well) to ensure minimum duplication and maximum synergy in a global environment. Not simply leadership, but strong and visionary leadership.

Agricultural research must address problems (current or projected), increase productivity while maintaining environmental integrity, provide products that are needed and wanted and which are affordable. A great leader must always be aware that resources are, and are likely to continue to be, a limiting factor that must be taken into account. However a leader can also influence those that provide the resources, thus channelling the resources more efficiently to address the vision and goals. The management and administration of those resources must also be done effectively, but the leader is in the position to influence donors, recognising that resources may often be directed with political or economic motivations rather than altruistic ones, but is able to direct resources to address his or her vision. Without visionary leaders, agricultural research would not be addressing the current needs of the world.

In one example, a leader was able to convince a donor, over several years, to realign some of their priorities to permit funding of some much needed agricultural research. The leader needed to spend time to understand the donor's constraints and requirements. After this a further period of time was required to develop an argument which could convince the donor to realign some of their funds, rather than producing a conflict between the leader's perceived research requirement and the donor's responsibilities. Of course, after agreement from the donor, the leader then had to be able to ensure that the research was conducted in a timely and efficient manner and that the impact was clearly visible. However, the investment of the leader's time and energy with the donor achieved the goal of realigning the donor's priorities and facilitating additional agricultural research funding.

Need for leadership

No organisation is without some form of leadership. There will always be the need for leaders, but in the absence of central leadership it devolves to individuals leading smaller units within the organisation whose vision and leadership will be followed. An organisation without a central leader is inefficient, with ill-defined goals, and an inability to address either its activities in pursuit of its goals, or the needs of its members, effectively. It is also clear that in almost all

cases, the leaders are, or have been, followers at some point. In many agricultural research situations the role of leaders is highly flexible. Project leaders may lead their team, but in turn they are led by a different leader to reach a higher goal. Within any one team there may be changes in leadership depending on the level of maturity of the particular group. This is true at all levels and in all situations.

Leadership is essential, but a true leader knows that they are not personally indispensable. A true leader can always retain the leadership role but is able to step back from, and delegate, the leadership as and when necessary (or appropriate), to ensure effectiveness in the organisation. This also ensures that a new generation of leaders is groomed and able to take up the task. The quality of leadership is sometimes judged by the leadership produced in others (Fullan, 2001). However, some leadership styles will preclude this delegation of leadership, and autocratic styles in particular may make this impractical.

Leadership helps a group to achieve its goals; it assists the members of the group to satisfy needs, but also mediates, initiates actions, and maintains the group as a functioning unit (Gibson et al., 2002) The leader represents and personifies the values, motives, and aspirations of the group. The leader is the focal point of the group and represents their views in interactions with other groups.

Types of leadership

Many factors can affect leadership and the style expressed at a particular time. Those who have most influence in organisations are usually those who hold formal leadership positions. Informal leaders are often well respected, but since they lack formal authority they usually have much less impact. However, their skills should not be underestimated as many informal leaders have had a major impact in many countries, as the politicians that were in power now clearly realise. In all leadership positions, it is in the decision-making process that leadership style is often most clearly visible.

In considering formal leadership, there are three clear styles: autocratic (authoritative), consultative (collaborative), and consensual (delegable).

In autocratic or authoritative leadership, the leader makes the decisions. The decisions may be made without any apparent consultation with subordinates, or may be made with some consultation where the subordinates' role is to provide information that may be evaluated by the autocratic leader, at which point the decision is made. Some will consider this form of leadership inappropriate, as group concerns are not always taken into account. Certainly some members of the group may find it difficult to react positively to this style of autocratic leadership. However, autocratic leadership is often effective and can implement decisions rapidly.

With the consultative style of leadership, the leader will share the problem with the subordinates either individually or as a group. This style makes the members feel part of the decision-making process and is more collaborative, although in

reality the members may have little or no authority in the decision-making process. In an individual sharing style the leader will exchange views on a one-to-one basis but opportunity is not provided for the subordinates to discuss the problem amongst themselves. When this type of leader meets with the members of the group, the leader will share the problem and obtain collective ideas and recommendations. The final decision made by the leader may or may not reflect the views of the subordinates, but their points of view or recommendations will be taken into account in the leader's decision-making process.

The third style is the consensual or delegable style of leadership where a problem is shared with the group and the consensus of the group is taken as the leader's decision. This is sometimes called a group style as the leader delegates the responsibility for the decision-making to the members and accepts the decision regardless of his or her personal views. This style is often slower in implementing change and can be self-defeating as the group or members may not have the larger centre, institutional or organisational vision as their priority in the decision-making process.

Many leaders in agricultural research management have to combine these leadership styles according to the particular circumstances at any one time. The vision and goals are a prerequisite, and charisma is a very positive trait. Even with this vision, goals and charisma the leadership style may need to be adapted according to need. In fact, the types of participation listed by Pretty (1995) for development programs and projects resonates well with the concepts of leadership styles, and perhaps also has some salutary lessons which all leaders, but particularly those in agricultural research, should be cognisant of. If we take participation, within the context of this discussion, to be participation in a group with a leader, the leader should be pleased if the participation is interactive and/or functional. This means that the team is working together towards common goals. At the extreme end of this continuum is the self-mobilised participation – in some sense this is positive, provided that the member works towards the common goal, with the team. However, the leader will have to monitor and evaluate the direction of the self-mobilised member. Moving from the extreme self-mobilised participation, through interactive and functional participation, there are the less palatable parts of the leadership process: the use of material incentives, passive and manipulative participation. Consultation is still an important leadership tool. However, the use of material incentives is more of a management tool to complete a task, not to build a sustainable solution. As the incentive is withdrawn, usually participation is also withdrawn. Passive participation comes with authoritative leadership. It has its role in certain situations, but requires a substantial amount of the leader's energy to maintain, as does manipulative participation. In a team with manipulative participation, as with passive participation, the leader will gain little from the group by way of initiative and willing contribution to the group's goals.

In agricultural research it is very important to ensure, as a leader, the right type of participation by the members of the group. A common difficulty in agricultural

research in a development context is that of ensuring effective participation by all the partners. Partnerships with national institutions are critical to assure funding by most donors, but many researchers fail to ensure their partners are sufficiently committed. In many cases the national partners are merely a name on a project document and a face around a meeting table. In many developing countries, where resources are limiting not only for agricultural research but also personally for those involved in the agricultural research, participation can often be ensured through the provision of incentives. While this can result in the name on the project document and a face at meetings, participation through the provision of incentives does not mean that the participation will be positive and contribute to the group's goals. Of course there are always exceptions, but in general incentives to participate are not usually as effective as some form of incentive or reward for high quality agricultural research, its implementation and its impact.

Some of the key issues that the leader will need to take into account in determining which leadership style to adopt at any particular time will include the quality and acceptance of the decision (Gibson et al., 2002). Overlaid on that is the size of the institution, the maturity of the institution and the members of the group (in terms of professional maturity) and the timescale for the decision-making process. A large research institution is at one level much more complex to lead, as there are many different facets of the institution that must be considered. However, a large institution usually has more resources that can be used to follow the vision of the leader. With respect to the maturity of the organisation, it is clear that new institutions are often more flexible and adaptable than older, well-established institutions. However, well-established institutions benefit from their experience, resources, and reputation. Professionally mature staff members are usually easier to lead, as they have more confidence in themselves and their peers and are less likely to question their own abilities. Professionally mature staff members know their abilities and the abilities of the institution. Although professionally mature staff members of any age are an asset to an institution, they can also be challenging to leadership as they question judgement and direction. A good leader will take this in a positive manner, as a sign of maturity and team effort as all concerned strive to contribute towards success of the institution. Much of leadership is about decision-making at one level or another, even reactive decision-making, and therefore the process and the consequences of any particular process are very important.

The quality of a decision is fundamentally determined by its outcomes, and the degree of positive impact on members of the organisation concerned. This includes aspects such as workflow, performance goals, work assignments, and funding allocation. In order to have any impact a decision will usually need to be implemented through action by others than the decision-maker. The information on which the decision was based usually has less impact on group motivation than the personal consequences of implementing the decision. The degree to which the members will be, or need to be, committed to the decision

is known as “decision acceptance”. The more that the execution of the decision will require the members to use initiative and judgement, the more likely it is that members will have to feel some acceptance of the decision. Similarly, if there is going to be a strong reaction to the decision, then again the members will need to feel some acceptance for the decision. If the group feels that they were part of the decision-making process or did in fact make the decision, they will be more likely to implement the decision effectively.

However, neither decision quality nor acceptance are sufficient to be able to judge or determine good leadership ability, because the confounding effects of the size of the organisation, the maturity of the organisation, the professional maturity and self-confidence of the members and the decision-making timescale will all impact on the decision making process and therefore the leadership style. A large organisation does not lend itself to all-inclusive consensus building. A small organisation can have informal group consensus based on strong, shared vision. Young organisations are often dynamic and motivated and some mature ones can be stagnant and introspective. However, some mature organisations have developed the ability and confidence to continue in a dynamic growth (as a result of effective and charismatic leadership?). The professional maturity of the members is also a key factor. Professionally mature staff is less likely to feel threatened by change and more able to accept new ideas in a dynamic environment. However, professionally mature does not refer to age, as leaders will clearly recognise. The more professionally mature the members, the more willing they will be to take responsibility and to make judgements on accepting the decisions of the leader with fairness and in the context of the organisational vision. The timescale in which a decision needs to be made will also influence the decision-making style. Where a decision needs to be made very quickly, there is little time for consultation, and probably no time for consensus, so the decision may have to be made in an authoritative manner. Outside factors are likely to be outside the leader's control and will influence the urgency of the need for a decision. However, a good leader will not allow these forced decisions to occur too often.

The historical context can provide a further influence to affect the leadership style shown in making a particular decision. When a leader has made a series of positive and successful decisions, the members are more likely to accept an authoritative decision based on the leader's track record and their respect for the leader, even though the natural tendency would be for the members to wish to participate in the process. On the other hand, one poor decision would be enough to demotivate the members of the group, institution, or organisation and they would be less accepting of future decisions and may challenge the leader.

An institution that has different agricultural research disciplines working together must find a way to separate the activities into manageable groups. In some institutions, or at certain levels within an institution it is possible, and sometimes necessary, to have multiple, strong leaders. This could, in the context

of agricultural research, refer to research thematic leaders who have a strong leadership role for their own particular group, but work within the organisation with their peer thematic leaders. For example, research activities could be divided in a disciplinary manner, according to agro-ecological or geographical programs, into thematic groups addressing particular targets, or a combination of these. The leader of the centre, institution, or organisation will in some manner, either by appointing (authoritarian) or through consensus, identify leaders of the subgroups within the institution to provide vision and guidance to the group. The leaders must also work together to represent all the subgroups in a forum to the institution and its leader, both to identify success and needs, as well as to identify longer-term goals to which all the subgroups must work towards. These thematic leaders, when working with their peers, again most likely will have a natural or appointed leader to express the views of the group. Rotating leadership is also possible, but the leaders must have commitment, vision, and skill to lead, and continuity must be ensured when the leadership of any particular group changes.

One of the difficulties of appointing leaders through consensus or through extensive delegated consultation is that the person identified may not have all the necessary skills to be a good leader. In one example, where teams of agricultural researchers who had worked together for several years in a mature organisation voted for their team leaders, the colleagues chosen as leaders by their peers indeed exhibited the traits of true leaders. Their colleagues chose the best person to lead them to the common goals based on many years of experience and the knowledge of what was required for the team to succeed and, perhaps as importantly, to be seen to succeed. However, in the same organisation, where all the researchers were expected to vote for higher-level leaders who would have significant decision-making authority that would affect resources and potentially affect individual researchers activities and their perquisites, the researchers did not always choose the best leader. Instead, in many cases it was the person who would either most favour the individual or, in the worst-case scenario, have the minimum negative impact. Where the group of members is not professionally mature, or the institution is seen by the members as having some inherent weaknesses, the leader of the institution must take great care in allowing the members to “elect” their own leader, so that the needs of the institution take precedence over individual wishes or needs.

Informal leadership is present in all organisations and is a critical facet to the functioning of the organisation or institution. An informal leader personifies the values and motives of the group (Gibson et al., 2002) and is often well respected. Without formal authority the informal leader is able to help a group to accomplish its goals. The informal leader is often a good listener and is able to express opinions in a positive and non-confrontational manner. Informal leadership is very flexible and can change according to need, or to the skills and knowledge of the leader, which may be pertinent to the current situation. Informal leaders are an asset to the formal leadership in guiding and motivating

the members, but informal and/or aspiring leaders can also be a major difficulty when the group does not agree with, or follow, the formal leader of the group or organisation.

Effective and ineffective leadership

Effective leadership is often situation-specific. Successful leadership in one environment does not automatically confer success in a different environment, but there are some common key elements that are more likely to make for effective leadership across contexts. These are good communication, ethical behaviour, and strategic thinking. A final measure of an effective leader is that they are followed.

Good communication skills are critical for effective leadership. The leader must be able to receive, assimilate and transmit information clearly, concisely, and effectively. In any organisation, it is vital that the leader receives information from the members, but similarly the members must receive information and decisions from the leader, and also have an opportunity for feedback. This is clearly an upward and downward flow of communication, but horizontal communication within the group is also critical.

There are many barriers to effective communication. A good leader will always remember that good communication (which is vital to their leadership position) will depend on the frame of reference of the members, value judgements, filtering, semantics problems and clarity, time pressure and specificity. Many of these are particularly important in agricultural research, as there is a diversity of researchers working on numerous issues that may or may not be pertinent to their own background or experience. In addition the researcher's output may or may not be implemented where they are able to observe the effect of their research. Communication is critical. If members of a group are unable or unwilling to communicate, the leader is already at a disadvantage and must facilitate communication both within the group and, often through the leader, outside the group. The receiver of communication, whether they are the leader or the members, will also make value judgements. The leader will assess any communication on the basis of previous knowledge of the member or group, while the member will hopefully accord high value to the leader's communication and will believe the source to be credible. In a large organisation, these value judgements will be made at many levels through the institutional hierarchy, so there can be filtering of the communication and information in both directions. This filtering is a vital part of management, but poor filtering can make leadership very difficult and will be an institutional management problem that requires attention. Within any communication, language and semantics can pose a major problem, particularly in a global research community – this is a challenge that any leader must overcome in order to be effective. The leader must also be aware that too much communication can waste time and will encourage aggressive filtering in order to maintain

productivity, and that time pressure, whether with the communicator or the recipient, will preclude effective communication.

A leader, especially in agricultural research, must act ethically within a number of levels of accountability to make appropriate decisions and judgements for the organisations. There are many technologies, processes and procedures available for agricultural research, and many global needs. However a leader must decide which goals are most appropriate and which tools to use, bearing in mind global needs with respect to food, the environment, health and the population, as well as more local needs and political or resource constraints. These needs must be interwoven in an ethical manner, and the goals presented with enthusiasm and commitment. The leader's decisions should be informed and strategic, combining long-term vision, with medium-term goals and short-term work-plans and activities. The leader will then be able to facilitate or catalyse the institution or organisation to deliver its products.

An effective leader will be able to make decisions that will be implemented effectively, efficiently, and willingly by the members, whether they are relatively minor decisions or major decisions that will require institutional change. An effective leader will be followed; an ineffective leader has to work very hard to pull the members along his or her preferred route to achieve the organisational vision.

Levels of leadership

As stated earlier, leadership occurs at all levels in an institution and this can be seen throughout agricultural research. Leadership at lower levels within an institution or organisation is a natural part of day-to-day working relationships as vision and goals are required for all activities. If the end product of a task is not known or envisaged, the task cannot be performed well, whether this is simply organising experiments or whether it is to develop a global network. Leadership at a higher level is more difficult to conceptualise, as there are more judgement-related aspects to the leadership.

In agricultural research, leadership can be categorised at the project, program/theme, centre/institution, network, and organisational or global levels. It is very important to have global leadership to ensure optimum use of global resources. Unfortunately, geopolitical realities and conflicts can make this idealistic view the most difficult to implement.

Project leadership is by far the simplest to define. The role of the project leader is constrained by the terms of reference of the project and predefined goals and outputs. The leader's task in this case is to motivate, take responsibility, and to coordinate, and the output of the project is one indicator of the leader's success.

Programme or theme leadership is also fairly simple to define as it is constrained by institutional mission, vision, and goals. However, there is some latitude in the leadership, more responsibility is required and some decision-making

needs may challenge leaders who are inexperienced. A leader of a programme or theme must still motivate the researchers, who are usually a diverse group but who still work under the umbrella of the same institution or organisation and who therefore share common goals. The main difficulty faced by the leader will be to ensure that the diverse backgrounds and research interests of group members can work harmoniously together to deliver the group products. There will undoubtedly be conflicts to be resolved based on differing academic points of view and on resource availability. Mentoring will also become another important role that the leader must assume. This raises another issue which becomes increasingly important at higher levels of leadership, that of delegation of authority with the delegated responsibility. For the theme or programme leader to be effective, higher-level management and leadership must delegate sufficient authority to the leader to facilitate the successful implementation of the leadership that the theme or programme requires.

The organisational or institutional leadership requires strong vision, in addition to the other qualities that leaders must have. Without the vision and ability to motivate, the leader becomes a manager and, while this manager/leader may well be able to keep the organisation or institution productive, the leader will lack the ability to implement change to help the institution or organisation to develop. The responsibility of leading an organisation or institution also requires a degree of risk management in the decision-making process. Not only are the goals and vision of the organisation or institution jeopardised by poor leadership, but also potentially the livelihood and careers of the researchers and staff involved. The leader must assess the benefits of any particular action and assess those benefits against any potential risks. At times the leader will need to take responsibility for the negative result of some decisions, but the damage accrued should be minimal if the leader had assessed the risks accurately and competently.

The leader of an institution or organisation often has a yet higher-level authority to which the leader is accountable. This can be a Board of Directors or similar instrument, which has responsibility for the overall direction of the institution as well fiscal as responsibility. In many cases the leader will work with the Board of Directors or equivalent body to ensure the smooth progress of the organisation or institution to the mutually agreed goals. However, this body can also provide the oversight needed to manage a leader who is not perhaps taking the institution or organisation in the expected or appropriate direction.

Networks are more complicated to lead, as they usually comprise diverse researchers in different institutions and at different levels of professional maturity. In agricultural research, these researchers are brought together by a common goal. But the cohesion of the network may be compromised if some of the members participate only to acquire resources or because there are material incentives to participate. Conflicts within networks tend to be more prevalent and geopolitical motivations can complicate the leaders' attempts to mediate. The opportunities presented by networks are far greater if the constraints can

be removed and the leader has the opportunity and ability to lead the network effectively.

Organisational leadership generally requires great vision and more highly developed skills. The leader of any organisation must have a vision and goals that can be clearly articulated and communicated. This vision must be communicated not only within the organisation, but must be clearly understood, be appropriate and be communicated outside the organisation. This is necessary to not only ensure that appropriate and effective partners can be found, but that the resources that the organisation needs to do its agricultural research can be acquired. With appropriately delegated authority (which will include using all the necessary management and administrative tools), the organisation can then be led to successfully achieve its goals. Figure 2 illustrates some of the complexities of leading an organisation, indicating the many different interactions and decisions that comprise organisational leadership.

Global leadership is a different issue. Global leadership can be by an organisation or by an individual. Sometimes an organisation is seen to lead global vision or opinion. The common perception is that it is the organisation that sets the standards and goals. However an organisation which is at the forefront of global activities will always have a strong and visionary leader of its own. Where the

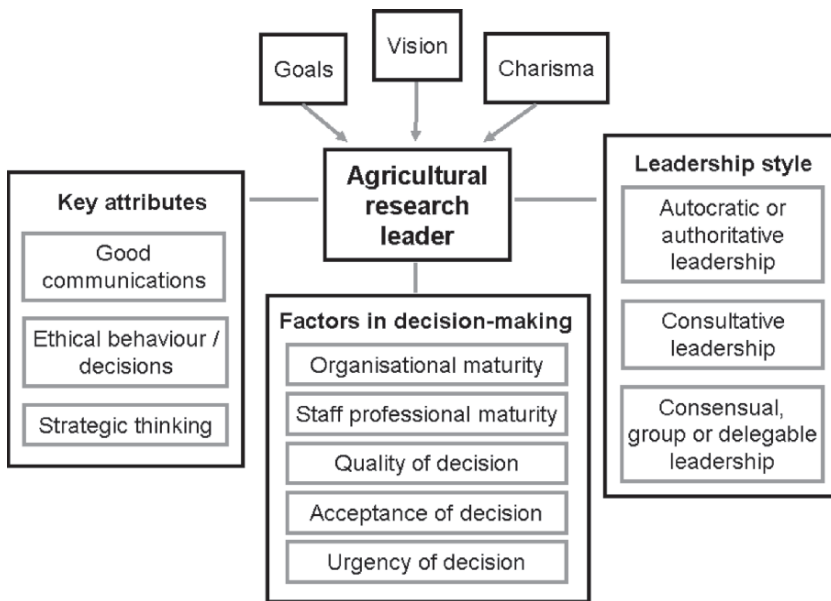

Figure 2. Attributes, leadership style, and decision-making in leadership at an organisational level.

organisation is a global leader, there will of course be that organisation's leader driving the vision of the organisation and its strategy. This then translates into the leadership by the organisation in a global forum. Global leadership in agricultural research influences whether certain technologies are advocated (e.g. technologies related to genetically modified crops) and, for example, whether development issues take up a significant part of a national budget and whether this is reflected in national agricultural research or only through development funding (e.g. the consensus on the Millennium Development Goals (MDGs) and subsequent reorientation on funding priorities). It also affects the relative proportion of investment by the public and private sectors on agricultural research.

VISION

The key tenet of leadership is to have vision and to be able to articulate and communicate that vision at all levels. All definitions of vision have a future direction and an image of where the direction will lead. Vision, communicated properly, inspires commitment. Nanus (1992) lists five principal attributes that will make a vision acceptable, attractive, and effective. The vision must attract commitment and energise people, it must create meaning in the members' lives, it must establish a standard of excellence, and it must bridge the present to the future and must transcend the status quo. These attributes are clearly applicable to vision as it relates to agricultural research.

All leaders will not only have a vision for the organisation, centre, or group; a true leader will have a personal vision of which this organisational, centre or group vision will be a part. The personal vision is what drives the leader. They know what they want, and where they want to be at some defined point in the future. Many leaders begin with a personal vision, which is then implemented by the wider group for which they have leadership responsibility.

Shared vision is the result of communication. It is vital that the members of the organisation or institution understand and are committed to the leader's vision – whether that vision was derived personally and authoritatively, by consultation or through consensus. Shared vision enables the vision to become reality. Dynamic, visionary leadership shapes an image for the desired future of the organisation or institution, communicates the vision and motivates and empowers the members to reach that vision (Westley and Mintzberg, 1989).

To lead the management of agricultural research, it is necessary to have a shared vision within the organisation. Equally important is the communication of the shared vision outside the organisation in order to secure resources to implement the vision. It is vital that the vision is communicated to stakeholders at different levels; to donors, partner organisations, and of course to the end users.

LEADERSHIP IN THE CURRENT AGRICULTURAL RESEARCH ENVIRONMENT

Several important issues in the current agricultural research environment are critical for higher-level leadership to address. These concern not only the function and impact of agricultural research as seen from both the global and local farmer levels, and all other positions along that continuum, but the process by which the research will be conducted, the resources the research will require, as well as conclusions, and how to achieve impact with the research results.

The agricultural research environment is a rapidly changing one, perhaps more so now than ever before. There are many global needs that are, with modern communications, better known than in the past. One of the disadvantages of current communication methods, particularly in the way that information is broadcast through the news channels, is the highly selective choice of material and information which is made available to the global audience. In times of natural disaster or other catastrophes, while the initial reports may be factual, the analysis of the cause(s) is often misleading or incomplete. This can lead to complete misunderstanding of the issues involved and distract from more important needs.

As more and more information becomes available, it becomes difficult to differentiate between useful information and that which is being used to inflame public opinion. In agricultural research, the researcher must become increasingly discriminating in assessing the quality of the data from the information that is available through print, electronic, and broadcast media. The task of the leader in providing the vision for the organisation or institution is therefore even more complicated and must often rely on analysis of information and data made by others to reach that vision.

Some key global issues were highlighted in the MDGs. While the needs of the developed world are to some extent different from the immediate needs of the developing world, there are many similarities and synergies. Sometimes the developed world already has a possible solution and the difficulty is in adapting that solution to the needs of the developing world. An example of this could be the ready market for goods from developing countries in the developed world. However, the non-tariff trade barriers which are put in place as a result of the demands imposed on the suppliers with respect to standards, by the developed countries, effectively exclude many developing countries from supplying this market. Either some support to the developing countries to meet those standards, or modification of some of the standards and requirements would facilitate the entry of developing countries into these markets. In other cases, the developing world has the answer to the needs of the developed world. In many cases these will be natural resources needed in the developed world. This could include plants with properties which could be utilised by pharmaceutical companies in developed countries or, as an example related to agriculture, crop species which could be a cheaper and more effective substitute for some the requirements of the food industry in developed countries.

The MDGs are not all directly related to agriculture, but given the reliance of the world's population on agriculture and agricultural products, the links between all of the MDGs and agriculture and agricultural research are clear. Of the eight MDGs, the ones most closely linked to agricultural research are to eradicate extreme poverty and hunger and to ensure environmental sustainability. However, the other MDGs of achieving universal primary education, gender equality and empowering women, reducing child mortality and improving maternal health, and combating HIV/AIDS, malaria and other diseases are also closely linked with agriculture and rural/urban development and require a global partnership for development. The disparities in progress to meet the eight MDGs are highlighted in *The Millennium Development Goals Report* (United Nations, 2006) and may in themselves reflect the differences in leadership of the different initiatives to tackle the different MDGs. If we examine the two MDGs most closely related to agricultural research, it is apparent that while chronic hunger is decreasing, the number of people who go hungry is in fact increasing. In contrast, some environmental issues are being addressed, although it is clear that the constraints related to agriculture worldwide are still affecting production adversely – in particular land degradation, water scarcity, and pollution.

At a global level one of the main considerations will be how to ensure that all the partners work together, both equitably and collaboratively, thus ensuring synergy and minimising unnecessary competition for resources. A key part of any global vision is the process for implementing the fruitful interactions between diverse players who are dealing with differences in needs, geographical location, political concerns, culture, language, skills and resource requirements, and constraints. Even perceptions of goals, resource needs, skill levels, and stakeholders can be very different, and it takes a leader with a clear vision who can communicate this effectively to all the players who will be able to meet the challenge of harnessing such diversity to be able to make a substantial impact.

A common misconception in agricultural research is that global considerations are donor-driven. In the short term this can be true, as short-term funding is already targeted for certain activities. In the long term it is the responsibility of the global agricultural research leaders to ensure that the donors will fund the needs that are perceived and articulated by the leaders. This does not happen overnight, but is a long and ongoing process, especially with respect to government funding. However, the grant-making foundations and other charitable donors are generally much more responsive. They are not accountable to governments for the expenditure, but they are accountable to their Directors, which may equally constrain their flexibility. In either situation, leaders of agricultural research have the responsibility to be able to persuade all levels of the urgency and the needs that they have articulated.

The persuasive skills of the leaders are not only required to directly obtain resources, but also to ensure that innovative and forward-looking processes are used to implement the agricultural research. Global networks, challenge programmes, and global initiatives are mechanisms that have to be assessed and

evaluated for their effectiveness, but new innovative ideas must also be developed, challenged, and if judged effective, implemented. Many donors are very conservative and unwilling to take the risk of funding new organisations or new mechanisms – one of the leader's roles is to assist these donor agencies to rethink their strategies to fit the rapidly changing agricultural research environment.

The most difficult leadership task is to maintain a determined vision to lead global or national agricultural research through to implementations that have an impact. But the challenges to lead an institution or organisation are not much different whether it is a university, a semi-autonomous research entity, an independent research institute, a government research programme, or coordinated multipartner research. It is as critical at such levels to be able to communicate a strong and visionary approach and to ensure team cohesiveness among the members so that outputs are delivered and impact is made. A key part of this is helping to create a common commitment within the team – who are not just a group of people doing their jobs, but a group with common goals and driven by common beliefs and values. Of course the policy, funding, and organisational environments will affect the processes that the leader can and will need to use, but the need to involve stakeholders at different levels of the decision-making process and to ensure effective communication will remain paramount goals to ensuring that the leadership can deliver.

IMPACT OF AGRICULTURAL RESEARCH ENVIRONMENT ON LEADERSHIP

The environment in which a leader is functioning will have an impact both on the effectiveness of the leader and the leadership style. An effective leader in one environment may not be able to perform in another environment. This is a critical point that is not always considered when decisions are made to appoint or confer leadership. The academic, public, and private sectors have different needs and requirements and the specific leadership qualities that may be required may differ, although the overriding requirement of visionary leadership and communication skills remain. Fielder (1967) proposed three factors which can influence a leader's effectiveness: leader–member relations, task structure and position power. It is clear that these three are variables that will be significantly affected in agricultural research leadership by the type of organisation (academic, public, private) and the organisation's historical leadership and status. These are challenges that any leader has to address to a lesser or greater degree.

Where a leader cannot bring an innovative approach and vision to an organisation or institution, it is still possible to lead the members, but the leader will have defaulted to more of a management role, which may be superfluous if there is already a good management structure and supporting administration in place. The role of management in supporting the leadership cannot be understated either – the critical role of managers in implementing the vision effectively and efficiently is one of the strategic tools of a leader.

An interesting issue is the perception of a good leader. As with many facets of life, the perception of “good” will depend on the subordinates’ beliefs and judgement, their social environment and needs, and their aspirations, as well as the perception of their peers. The perception of “good” by the leader’s peers or superiors may differ from the perception of his or her subordinates or the group being led. The peers or the leader’s superiors will have different reference points on which to base their judgements of “good” leadership. The perception of appropriate leadership qualities is therefore dependent on the context. And it is important that institutions find leaders that can lead the institution and organisation in the desired direction, but also for leaders to find institutions, organisations or causes that can use their particular leadership skills and experience effectively.

BUILDING LEADERSHIP CAPACITY IN AGRICULTURAL RESEARCH MANAGEMENT

As leadership is so important in assuring successful agricultural research and fostering effective agricultural research management, it is vital to ensure that leadership capacity is built and maintained in the current agricultural research environment.

Solutions that will enable agricultural research management, both globally and locally, to achieve its aims, must be built around responsibility, incentives, organisational support, and resources. When discussing leadership capacity development, it is clear that this must begin early in the individual’s career when there is strong motivation but a high level of personal management is needed and there are fewer leadership responsibilities. As the career develops, the level of leadership increases and management decreases as a scientist moves from a research to leadership role. Some scientists are unsuited to a leadership role and have no interest in being leaders, and some great agricultural research leaders have little experience in research.

It is also possible to bring expertise from outside the organisation or institution, or even from outside the agricultural research system, with a very different viewpoint of the organisation or institution’s goals. In many cases, depending on the context, it may be possible to bring in leadership expertise from outside the system. On the one hand, this brings fresh vision, new ideas, and someone who is not constrained by the traditional systems and processes. On the other hand, there is a very steep learning curve for someone to tackle new issues and challenges effectively. If the leader is from within the same sector, the leader will have significant background knowledge, experience and provide continuity. However, experience and lessons learned from other sectors will be missing.

The actual process of building this leadership capacity can be formal (through courses and training for staff development) or informal through mentoring and on-the-job learning. The process of building future leaders itself requires leadership and vision. Good leadership is needed to foster this human resources

development, and it is necessary to have defined the leadership skills required and the challenges and opportunities that are presented. For instance, current initiatives within the Consultative Group on International Agricultural Research (CGIAR) include the Gender and Diversity Women's Leadership courses and its Harvard Management & Leadership courses. Many national governments also run leadership training courses for different levels of staff, and many research institutions both in developed and developing countries have recognised the need to foster leadership potential. Development agencies are also fully aware of the need for staff development particularly in research leadership (University of Toronto, 2005). The private sector has often ensured that their staff is trained and leadership skills in particular are developed and focused on corporate needs in order to facilitate the corporate development and the need to ensure profits, which will pay their staff.

THE ART AND SCIENCE OF LEADERSHIP IN AGRICULTURAL RESEARCH MANAGEMENT

A visionary leader in agricultural research management has to combine many roles, and will probably have a lot of experience on which to draw. It is not possible to give a definitive recipe for what makes leadership work, as most good leaders will challenge any set process or procedure. They will challenge in a positive way, with the intention of improving it, but they will not fit into any stereotype that could be defined.

Any shared vision must be inspiring. To know, feel, and understand what inspires any particular group of people will depend on the environment and context – this is part of the art of great leadership. To merely inspire is insufficient – a leader must find a way to ensure the job is done (and done well), either by demonstrating the way, or guiding the process.

Leaders must understand themselves, not only the vision they are seeking to communicate, but their own strengths and weaknesses. They must be able to build on their strengths and to demonstrate confidence. If a leader does not have confidence in his or her vision, no one will!

In agricultural research management, the members who are to be led will generally have strong opinions, be free-thinking and may be highly critical. However, these are characteristics of good research scientists and therefore the leader must be willing and able to take on this challenge where even the most enlightened and visionary leaders will be criticised by the members of the group. There is an art to leading and managing agricultural research, where not only the research is of critical importance, but perceptions of the end product, ethical and political issues, and environmental concerns also influence behaviour and therefore the task of the leader.

Leadership in agricultural research management is usually challenging, and often with many more constraints than opportunities. However, with effective leadership of productive groups, institutions, or organisations, agricultural

research can and will deliver products which can affect the lives and livelihoods of every person on the planet. The leader's role is to make sure that this impact is positive and that the agricultural products are produced safely and efficiently, regardless of where the product is grown and where it will be consumed, and that a strategy is in place to address the needs of a growing population, with disparate resources and needs, around the world.

REFERENCES

- Fiedler, F.E. 1967. *A Theory of Leadership Effectiveness*. McGraw-Hill, New York.
- Fullan, M. 2001. *Leading in a Culture of Change*. Jossey-Bass, San Francisco.
- Gibson, J.L., Ivancevich, J.M., Donnelly, J. H., Jr., and Konopaske, R. 2002. *Organizations Behavior, Structure, Processes*, 12th edn. McGraw-Hill, New York.
- Pretty, J. 1995. Participatory learning for sustainable agriculture. *World Development* 23: 1247–1263.
- Nanus, B. 1992. *Visionary Leadership: Creating a Compelling Sense of Direction for Your Organization*. Jossey-Bass, San Francisco.
- United Nations. 2006. The Millennium Development Goals Report 2006. <http://mdgs.un.org/unsd/mdg/>
- University of Toronto. 2005. Summary Report: National Workshop on Research Leadership and Management. 31 October–1 November. <http://www.utoronto.ca/hpme/infocus/2006/2006-1.html>
- Westley, F., and Mintzberg, H. 1989. Visionary leadership and strategic management. *Strategic Management Journal* 10: 17–32.

CHAPTER 7

BIOETHICS IN AGRICULTURAL RESEARCH AND RESEARCH MANAGEMENT

ANNABEL FOSSEY

*Forestry, Natural Resources, and the Environment, CSIR, PO Box 17001, Congella,
Durban 4013, South Africa*

INTRODUCTION TO BIOETHICS

Ethics is a field of study looking at moral standards that govern the appropriate conduct for an individual or group of individuals. Simply, ethics can be defined as a method, procedure, or perspective, or norms of conduct that distinguishes between acceptable and unacceptable, right or wrong, behaviour. In the field of ethics, the term “bioethics”, first coined by Potter in 1970, is a relatively new term when compared to medical ethics and the philosophy of science. Potter proposed a new discipline as “the science of survival,” which “would attempt to generate wisdom, the knowledge of how to use knowledge for social good from a realistic knowledge of man’s biological nature and of the biological world”. In 1998 Macer proposed a simpler definition by referring to bioethics as “love of life” involving analysis of the benefits and risks arising out of the moral choices affecting living organisms for the good of individuals, the environment, and society. Today, bioethics is an integrated discipline involving ethical analysis of participants that could be affected by decisions taken. Ethical enquiries address ethics and life sciences connecting new developments in technology, biotechnology, medicine, biology, and environmental sciences with social sciences like philosophy, religion, law, and public policies.

People obtain their values from their parents, families, and teachers, who in turn are guided by their surrounding culture. The world’s great varieties of cultures are moulded through teachings in schools, politics, television, the media, books, the law, faiths, and philosophies present in societies. Many people’s beliefs about what is right and what is wrong, what should be accepted and what should be rejected, is greatly influenced by the various religions in the world, often referred to as worldviews. We therefore find great variation in what the

different peoples of the world believe is right and wrong. We may be tempted to want our own traditions to count more than those of others, which is problematic under a democracy. In a democratic society a cardinal principle is that we all have equal rights and must respect one another's cultural differences. It is thus important to be ethical about ethics itself. Although it is a reality that different societies have different moral values, there is consensus about the important core moral values:

- Generosity and compassion
- Inclusiveness
- Fairness and justice
- Truthfulness and integrity
- Freedom
- Respect, including self-respect
- Effort and perseverance
- Responsibility

Bioethics in agriculture is a rich field of applied ethics and is viewed more broadly, to include ethical evaluation of all actions that might help or harm organisms capable of feeling fear and pain. Questions about animal rights, business ethics, food ethics, genetically modified organisms (GMOs) and foods, political ethics, land ethics, and environmental ethics all feature in agricultural bioethics. One of the important ethical questions in agriculture is: Is there justification for the use of modern agricultural biotechnology tools such as recombinant DNA techniques, commonly known as genetic engineering, to create new genetic organisms?

The four fundamental principles of bioethics include:

Beneficence, which refers to the practice of good deeds

Non-maleficence, which emphasizes an obligation to not inflict harm

Autonomy, which recognises the human capacity for self-determination and independency in decision-making

Justice, which is based on the conception of fair treatment and equity through reasonable resolution of disputes

ETHICAL DECISION-MAKING IN RESEARCH

Research is the methodical investigation into a subject in order to discover facts, to establish or revise a theory, or to develop a plan of action based on the facts discovered and includes all basic, applied, and demonstration research in all academic and scholarly fields. Scientific knowledge gained through research and agricultural practices are forms of power. As such power can be used for good as well as for evil; ethical norms are needed to guide the responsible generation and application of scientific knowledge. We can summarise the major features that characterise the nature of scientific knowledge as follows:

- It is the result of human imagination, creativity, and how scientists visualise phenomena.

- It is indefinite in nature, changing constantly, and requiring constant revision and re-evaluation.
- It is influenced by cognitive skills, practical skills, as well as scientific methods and their limitations, used in the scientific processes.
- It is influenced by conceptual understanding and interpretation of results and the theories and laws used to describe phenomena and relationships.
- It is dependent on the consensus view of the community of scientists. There are, however, “grey” areas that may or may not become generally accepted by the scientific community.

In scientific research, ethics relates to both the “values of science and scholarship” and “standards of conduct and practice in science”. It is expected that one exhibits honesty and reliability, designs and performs experiments with skill and thoroughness, and is fair in dealing with students, co-workers and competitors, and assumes responsibility to people and institutions. The vast majority of decisions that people make in the conduct of research involve the straightforward application of ethical rules. Research can be said to be ethical in two different ways:

- Ethics of the topics and findings (morality)
- Ethics of method and process (integrity)

Many different disciplines, professional associations, government agencies, research institutions, and universities have adopted professional codes that relate to research ethics. Such a code is a statement of shared values; it contains a prescription for right actions and can be seen as a framework for sound research practice and for the protection of researchers from possible misunderstandings. Although codes vary and display many differences, they mostly include the following ethical principles listed in Box 1.

Adherence to ethical norms is important to:

- Promote the aims of research, such as knowledge, truth, and avoidance of error
- Promote the values that are essential to collaborative research, such as trust, accountability, mutual respect, and fairness
- Ensure that researchers are held accountable
- Help to build public support for research
- Promote other important moral and social values, such as social responsibility, animal welfare, compliance with the law, and health and safety

Agricultural research, which is highly applied in nature, is aimed at discoveries and technology development and has traditionally been conducted by research institutions and universities. Today many large corporations employing biotechnologies contribute to a large body of agricultural research. In agricultural research, ethical issues are of particular interest when examining technology, and especially so with respect to genetic engineering and animal cloning. Ethical issues in agriculture include problems, in part, with food safety and security, animal welfare and production, technological change and agricultural production techniques, pollution and environmental sustainability, and corruption of regulators and policymakers. The view that scientists are, in general, trustworthy

Box 1. Ethical principles

Objectivity

To avoid bias in experimental design, data analysis, data interpretation, peer review, personnel decisions, grant writing, expert testimony, and other aspects of research where objectivity is expected or required.

Honesty

To honestly report data, results, methods and procedures, and publication status.

Integrity

To comply with agreements; act with sincerity; strive for consistency of thought and action.

Confidentiality

To protect confidential communications, agreements, and trade or military secrets.

Carefulness

To avoid careless errors and negligence.

Openness

To share data, results, ideas, tools, resources, and be open to criticism and new ideas.

Competence

To maintain and improve your own professional competence and expertise through lifelong education and learning.

Respect for Intellectual Property

To honour patents, copyrights, and other forms of intellectual property; acknowledge all contributions to research.

Responsible Publication

To publish in order to advance research and scholarship, not to advance just your own career; avoid wasteful and duplicative publication.

Responsible Mentoring

To help educate, mentor, and advise students.

Respect for Colleagues

To respect colleagues.

Social Responsibility

To strive to promote social good and prevent or mitigate social harms through research, public education, and advocacy.

Non-Discrimination

To avoid discrimination against colleagues or students on the basis of sex, race, ethnicity, or other factors that are not related to their scientific competence and integrity.

Legality

To know, understand, and obey relevant laws and institutional and governmental policies.

Animal Care

To show proper respect and care for animals used in research.

and ethically sound and that agricultural research is intrinsically good has been altered since the advent of genetic engineering. It is generally recognised that these new technologies challenge existing values and systems and stimulate change in traditional concepts of nature and human identity.

Four approaches that provide useful frameworks for analysing ethical issues in agriculture have passed the test of time:

- Utilitarianism (teleology, consequentialism)
- Deontology
- Virtue ethics
- Rights ethics

Utilitarianism (also known as consequentialism or teleology) derives from Bentham (1781) and Mill (1861). It is concerned with the *outcomes* of ethical behaviour, rather than the motives that underpin it. This view says that we ought always to do whatever maximises the balance of pleasure over pain for all affected by our action. Utilitarianism is very much a “means justify ends” view of ethics.

Where utilitarianism focuses on the consequences of an act; deontology (derives from Immanuel Kant, 1724–1804) focuses on the motives for it. This is a moral theory according to which certain acts must or must not be done, regardless to some extent of the consequences of their performance or non-performance.

Virtue ethics derives from Aristotle and has something in common with Kant in its emphasis on the individual. Aristotle argued that people have inherent potential and the basic criterion for judging any human action is whether or not it enhances this potential; mentally, morally, and socially.

The rights of the individual are regarded as supra-legal entitlements shared equally and universally by all people. At the most basic level, people have the right to subsistence, security, and liberty. The basic rights are seen as a precondition for the exercise of more complex rights.

THE RESEARCH PROCESS

Ethics and integrity in the conduct of research are critical to the advancement of scientific knowledge. As concerns about potential misconduct in the scientific community have increased, it has become more and more important to discuss and describe ethical standards and scientific misconduct that relate to research. Establishment of regulatory ethical standards and procedures for inquiry and investigation of allegations of scientific misconduct strengthens the self-regulation of the research community. Researchers are responsible for the validity and quality of scientific data, fulfilling all scientific research and publication standards, and orienting students, research fellows, and colleagues to scientific standards, policies, and procedures and ensuring that they are upheld. It is therefore imperative that researchers understand the concepts that underlie ordinary morality and understand that this morality applies to scientific practice.

A discussion of the different ethical issues that pertain to the different components of the research process in agricultural research is the main focus of this document.

RESEARCH MISCONDUCT

The prevalence of unprofessional behaviour in research is one of the greatest threats to the integrity of research today. Although most cases of *Research misconduct* or *Scientific misconduct* do not actually violate the law, the major characteristics are the same. Honest errors or differences in interpretation or judgments of data are not regarded as misconduct. Misconduct in research occurs at all stages of the research process.

When the research community, funders, and decision-makers are deceived by giving false information or the presentation of false results, this is *scientific fraud*. The four categories of fraud are: fabrication, falsification (misrepresentation), plagiarism, and misappropriation. Fabrication is when data or results are made up, thus fabricated. Falsification is when data or results are intentionally manipulated, changed, or omitted. Plagiarism is the presentation of someone else's ideas, thoughts, theories, research plans, words, pictures, or data as your own, without the appropriate acknowledgement. Misappropriation is when a researcher illicitly presents or uses his/her own name for an original research idea, plan or finding disclosed to him/her in confidence.

Research institutions and universities take allegations of research misconduct seriously and have formal procedures for investigating and resolving such allegations. Failure to comply with the ethical code of conduct may be regarded as gross misconduct and result in disciplinary action, which could include dismissal.

Procedures that deal with misconduct have been adopted by many research institutions and universities and are all very similar. Any person, the whistleblower, who knows of unethical research conduct, should raise concern to the appropriate authority, whether involved in the research or not. The whistleblower should be treated with "fairness and respect" by the institution and efforts should be made to protect their job and reputation. The person suspected of research misconduct (the respondent) should also be protected and treated with "fairness and respect" by the institution. The representative of the appropriate authority should make every effort to maintain the confidentiality of both the whistleblower and the respondent. Once misconduct has been identified, all parties involved in the research should attempt to resolve the situation by first launching an inquiry. If this inquiry reveals potential research misconduct, a full-scale investigation is to be undertaken. Thereafter, decisions concerning the presence of misconduct, severity, and appropriate corrective action, should be taken, if needed.

A finding of research misconduct usually requires that:

- There is significant departure from accepted practices of the relevant research community

- The misconduct was committed intentionally, knowingly, or recklessly
- The allegation is proven by a preponderance of evidence

ETHICAL ISSUES THAT PERTAIN TO THE PREPARATION PHASE OF THE RESEARCH PROCESS

Choice of research topics

Over the last 20 years or so, there has been a “revolution” in the life sciences, recognising a dramatic increase in our knowledge and capabilities. The implementation of the newer agricultural biotechnologies has met with considerable controversy and concern to many people across the world. Not only are the views and opinions conflicting at a scientific level, but also in the ethical and moral issues surrounding the use of these technologies.

At the international level, a standard definition of biotechnology has been reached at the Convention on Biological Diversity (CBD), which defines biotechnology as “any technological application that uses biological systems, living organisms or derivatives thereof, to make or modify products and processes for specific use”. Agricultural biotechnology can therefore be defined as a collection of scientific techniques, including genetic engineering, used to create, improve, or modify plants, animals, and microorganisms.

Using conventional techniques, such as selective breeding, scientists have been working to improve animals and plants for human benefit for hundreds of years. Modern biotechnology now enables scientists to clone animals and to move genes amongst unrelated species that are not naturally able to mix their genes, thereby producing transgenic animals and plants, better known as genetically modified organisms (GMOs). This technology is one of the most controversial technologies used in science today, bringing about excitement, fear, and many concerns.

Animal biotechnology can be broadly categorised to encompass asexual reproduction through cloning and genetic transformation. Most plant biotechnology, about 80%, is directed towards the improvement of food plants; the remainder of the work being concerned with non-food crops such as tobacco, cotton, ornamental plants, and pharmaceuticals.

Genetic modification is considered in three broad areas, namely in terms of input traits, output traits, and value-added traits. Input traits help farmers and producers by increasing production efficiencies, and are achieved through faster and more efficient growth rates, resistance to diseases, and the improvement of production traits such as increased milk or crop yield. On the other hand, output traits contribute to consumers or downstream processing by enhancing the quality of the livestock or crop product. This is achieved, for example, through the production of leaner and tenderer meat or by producing milk or wheat lacking allergenic proteins. When GMOs display completely new functions after genetic modification, these are considered to be value-added traits.

The technologies used in animal biotechnology are varied, complex, and impact on many different areas in animal research, production, and breeding. The cloning of the ewe named Dolly by Scottish researchers at the Roslin Institute Scotland in 1997 marked the beginning of a new era in animal research, bringing to the forefront the value of cloning, the possibility of extensive use of animal transformation and its potential use in humans. It also brought into focus the risks of these technologies, resulting in worldwide debates addressing the ethical implications of these technologies. The technologies used in animal biotechnology include, and this is by no means an exhaustive list; oocyte pick-up, a procedure to recover oocytes *in situ* from both adult and juvenile females by aspirating ovarian follicles; semen and embryo sexing that improves the efficiency of production systems; genetic transformation; animal cloning; and pronuclear injection, the microinjection of DNA (genes) into one-celled embryos (single recently fertilised eggs).

In plant biotechnology, tissue culture has become an essential tool in modern plant breeding and production, and is also one of the corner-stone technologies in the production of GMOs, permitting the rapid multiplication (cloning) of transformed plants. Genetic modification of food crops and non-food crops has become a multibillion-dollar business worldwide. Plants are transformed by introducing DNA through a natural vector, the soil bacterium *Agrobacterium* and through ballistic impregnation in species that are incompatible with *Agrobacterium*. In ballistic impregnation, DNA stuck onto minute tungsten or gold particles is “fired” into plant tissue where it is taken up in the plant’s cell.

There is no doubt that modern biotechnology represents a major breakthrough in scientific research. Unlike the prospects of human cloning, scientists are excited about the endless prospects of animal cloning. Using genetically identical animals in research experiments could bring about the reduction of the number of animals used, and better control over experimental conditions. It is envisaged that the use of animal clones or cloned cells would, for example, make excellent models for research, lead to a greater understanding of embryo development, and supply answers to the underlying processes of ageing. Cloning of superior animals could produce superior herds in a single generation and replenish animal numbers of endangered species. In the medical field the application of xenotransplantation – the replacement of diseased human organs with animal organs – could become a reality.

The uses of animal GMOs are wide-ranging. GMO farm animals have been produced, such as cows that produce more milk, sheep that produce more wool, and fish that survive colder temperatures than normal. Research, for example, is continuing on the analysis of the regulation of gene expression and to produce pigs with modified immune systems for their use in xenotransplantation.

Plant biotechnology promises to feed more people by helping farmers increase crop yields by planting better adapted, more pest- and disease-resistant, and more nutritious varieties. Growing crops transformed with herbicide- and insecticide-resistant genes will also reduce the effects of herbicides and insecticides on the

environment. Many novel processes are also seeing the light, such as delayed ripening of fruit, production of vaccines, pharmaceuticals, and biodegradable plastics in crops.

Ethical issues that Pertain to biotechnology

The view that scientists are, in the main, trustworthy and ethically sound and that agricultural research is intrinsically good has been altered since the advent of genetic engineering and related biotechnologies. It is generally recognised that these new technologies challenge existing values and systems and stimulate change in traditional concepts of nature and human identity. Within the next few years literally thousands of genetically modified food products or products with genetically modified components could be put onto the world market.

Animal biotechnology is morally a sensitive issue. It is primarily cloning and genetic transformation that raise the vast majority of ethical concerns. The pursuit of these technologies addresses four main categories: health, products, the environment, and business. People are concerned about the treatment of animals and the nature of modern biotechnology itself. The potential benefits of animal biotechnology are vast, but genetic modification and manipulation of animals raises a variety of ethical concerns, which are either intrinsic, concerns about fundamental moral objections to the human use of animals or specifically to their genetic modification; or extrinsic, concerns about the consequences of these actions.

Modern biotechnology is viewed by some as intrinsically wrong because of the belief that nature and all that is natural is valuable and good in itself. From religious perspectives, animal biotechnology may also be viewed as wrong to varying degrees. Therefore, modern biotechnology is viewed as being unnatural in that it goes against nature.

There is no doubt that animal genetic transformation is more powerful than traditional genetic breeding providing limitless opportunities for mixing genes from widely different and distantly related species bringing about genetic change in a single generation. This presents new ethical issues not raised with traditional selective breeding. For instance, genetically transformed animals create particular problems for some religious groups. For example, Muslims, Sikhs, and Hindus are forbidden to eat foods containing genetic material from animals whose flesh is forbidden. While some believe that the transferring of a gene from an animal to another organism does not involve the identity, others argue that it is precisely the genes of an individual that make it distinctive.

Another question is whether genetic transformation violates “biological boundaries”. Thus, some argue that traditional breeding offers protection against crossing “biological boundaries”, while others argue that all biological organisms share most of the same genes anyway and that “biological boundaries” are really very fuzzy.

Genetically modified (GM) crops have changed the nature of plant breeding substantially, raising a number of practical and ethical implications/concerns.

These centre around the associated risks and benefits to humans and the environment, the balance of the distribution of benefits, and on the technology being good or bad in itself. The major concerns for the development and deployment of GM crops refer to: the risks, the benefits, and the impact on the environment, which are referred to as “extrinsic” concerns.

Currently relevant questions are being asked about the safety of GM crops that are entering the food chain and being released into the environment:

How safe is food derived from GM crops?

What changes to the environment (ecosystems) will the release of GM plants pose?

Do GM crops represent the solution, or partial solution, to world hunger?

How can equitable sharing of the benefits of technological advancement be improved?

Will this technology be able to revolutionise farming, save the environment, and make money and thus address humanitarian, environmental, and business ethics simultaneously?

Scientists’ relationships with funding sources

An investigator should be aware of the seriousness of a research proposal and should be written to the same standards of accuracy as that of a manuscript. Funding agencies often provide guidelines for the use of research funds. It is the responsibility of the principle investigator (PI) of the research team to ensure that these guidelines are followed scrupulously as well as the guidelines on the management and disbursement of funds provided by the research institution or university. It is not permitted to divert any research funds for personal or any other use, except in cases where the grant or contract specifically provides otherwise. Researchers who enter into agreements with commercial sponsors of research should familiarise themselves with the special terms of such agreements, especially those that pertain to the reporting of the results. Experiments not yet performed as evidence in support of the proposed research, is considered to be fabrication and is subject to a finding of research misconduct.

ETHICAL ISSUES THAT PERTAIN TO THE PROCESSING PHASE OF THE RESEARCH PROCESS

Integrity of science and scientists

Due to the ever-changing nature of science and the views of the scientific community, a scientist may be proclaimed a hero at one time but be booed at another. Many methods in the past, although accepted at the time within a particular framework of scientific knowledge, might not be acceptable today, therefore, scientists are constantly challenged to question, to review, and to re-evaluate so that scientific processes and research becomes more refined, effective, and transparent.

The ethical acceptability of scientific research and the credibility of research findings entail that scientists conduct research in keeping with good scientific practice. The integrity of scientists is about maintaining a trustworthy and respected reputation amongst the scientific community and the greater society of people. Although this seems to be an easily attainable quest, the fragile trust of human nature might need only one negative statement to cause irreparable damage creating negative perceptions in the public, eroding scientific norms, and harming individuals, thereby damaging the integrity of science. There is no single code of ethics of scientists, but most scientists accept ethical principles that require that scientists:

- Understand the basic nature of science
- Undertake scientific research within their areas of competence
- Use acceptable scientific methods, interpret data, and report results objectively and honestly
- Conduct their scientific practice in an ethical manner and disclose unethical conduct
- Constantly question, review, and re-evaluate scientific knowledge, thereby promoting an image of trustworthiness and consequently promoting public understanding of scientific practice

The maintenance of research integrity rests upon trust and self-regulation of the individual(s) in the scientific community. Self-regulation assumes that scientific peers will examine research presented by fellow scientists and if not found credible, will report this together with corrected information to the scientific community as part of the normal course of scientific inquiry. Since science comprises many subdisciplines and subspecialities each with its particular characteristics, no single method of judging is possible. Thus, scientists within all the different areas of scientific expertise are required to participate in the process of self-regulation, thereby ensuring and protecting the integrity of science.

Responsibilities of a research supervisor

It is customary that a senior member of a research team, the PI, has supervisory responsibilities with respect to the research performed by members of the group and should check the details of experimental procedures, validity of the data or observations, and the presentations and publications of the research group. Legal agreements are usually the responsibility of the research office of the particular university or research institute.

Research institutes and universities usually have a code of ethics. It is the responsibility of the PI to ensure that all members of the research team work in accordance of these guidelines.

Animals in research

Animals have been used in basic and applied research for more than 2,000 years. Debate about the acceptability of using animals in research has been contested

for a similar length of time. The use of animals in modern scientific research, agriculture, and biotechnology, has brought into focus the fundamental question of how we see animals. Traditionally, people have attached a great deal of emotional and cultural significance to animals and thus concern for their welfare. Another reason relates to the fact that animals are closer to humans in an evolutionary sense than are plants or microbes. People therefore, generally accept that animals have some basic rights. The promised benefits of the application of these technologies in research can only be realised if the research is based on ethical norms. The public gets upset when they sense that scientists cross ethical and emotional lines.

The modern animal rights movement can be traced to the 1970s when a group of philosophers at Oxford started to question the moral status of non-human animals. Richard D. Ryder, a member of this group coined the phrase “speciesism” in 1970 to describe the assignment of value to the interests of beings on the basis of their membership of a particular species. An animal right is the concept that all or some animals are entitled to possess their own lives and that they deserve certain moral rights; some of these rights are captured in the law. Few people would deny that non-human primates are intelligent and aware of their own condition and goals. This view rejects the concept that animals are merely goods for the benefit of humans. Often this view is confused with animal welfare, which is the philosophy that takes cruelty towards animals and animal suffering into account, but does not necessary assign species a moral right.

The two most prominent proponents of animal rights are the Australian philosopher Peter Singer and the American philosopher Thomas Regan. Singer’s approach to an animal’s moral status is not based on the concept of rights, but on the utilitarian principle of equal consideration of interests. In his book *Animal Liberation* (1975) he argues that humans grant moral consideration to other humans on the basis of their ability to experience suffering, rather than because of their intelligence or ability to moralise or any other attribute that is inherently human. As animals also experience suffering, he argues, excluding animals from such consideration is a form of discrimination known as “speciesism”. Singer further argues that the way in which humans use animals is not justified and that the suffering of most animals should be given equal consideration to the suffering of most humans. He maintains that it is possible to obtain the equal benefits in ways that do not involve the same degree of suffering.

Tom Regan sets out a rights-based approach in his book *The Case for Animal Rights* (1984) and argues that non-human animals, as “subjects-of-a-life”, have the right to be treated with respect as sentient beings with inherent value and cannot be regarded as means to an end. According to Regan, we should abolish the breeding of animals for food, animal experimentation, and commercial hunting. His theory does not extend to all sentient animals but only to those that can be regarded as “subjects-of-a-life”. He argues that all normal mammals of at least one year of age would qualify in this regard.

While Singer is primarily concerned with improving the treatment of animals and accepts that in some instances animals can be used legitimately for human

use, Regan believes we ought to treat animals as we would persons and never a mere means to an end. Despite these theoretical differences, both Singer and Regan agree about what to do in practice. For example, they agree that the adoption of a vegan diet and the abolition of nearly all forms of animal experimentation are ethically mandatory.

In practice, animal rights activists usually boycott a number of industries that use animals such as factory farming and the transportation of farm animals for slaughter. Most animal-rights activists adopt vegetarian or vegan diets, avoid clothes made of animal skins, and will not use products such as cosmetics, pharmaceutical products, known to contain animal by-products.

The mainstream position of the scientific community is that humans and certain animal species have intrinsic value, but they recognise the use of animals in research for the advancement of human and non-human health and well-being. In recognition of the intrinsic value of animals, their scientific use is privileged and conditional on the safeguard of their welfare and the minimisation of pain in scientific procedures.

Code of practice

Many governments have designed codes of practice and legislation to ensure the ethical and humane care and use of animals used for scientific purposes. Such codes usually encompass all aspects of the care and use of, or interaction with animals for scientific purposes in medicine, biology, agriculture, veterinary and other animal sciences, industry, and teaching. It includes the use of animals in research, teaching, field trials, product testing, diagnosis, the production of biological products, and environmental studies. These codes provide general principles for the care and use of animals, specify the responsibilities of researchers, teachers, and institutions, and detail the terms of reference regarding the monitoring committees, referred to in many countries as Animal Ethics Committees (AECs).

In general, these codes emphasise the responsibilities of investigators, teachers, and institutions using animals so that:

- The use of animals is justified, taking into consideration the scientific or educational benefits and the potential effects on the welfare of the animals
- The welfare of animals is always considered
- The development and use of techniques that replace the use of animals is promoted
- The number of animals used in projects is minimised
- The methods and procedures are refined to avoid pain or distress

When planning research, animal welfare is an essential factor. Research institutions and universities must ensure that all animal use conforms to the standards of the code. There are often difficult ethical judgements to be made regarding the use of animals for scientific purposes, but it is generally accepted in the scientific community that when the use of animals is considered, adherence to the principles of *replacement*, *reduction*, and *refinement* (3Rs) should be ensured.

Replacement requires that techniques that totally or partially replace the use of animals for scientific purposes must be sought and used wherever possible.

Reduction requires that each project must use no more than the minimum number of animals necessary to ensure scientific and statistical validity and that research or teaching activities not be repeated unless essential.

Refinement requires that animals must be suitable for the scientific purpose and their welfare the primary consideration in the provision of care. Animals should be transported, housed, fed, watered, handled, and used under conditions that meet species-specific needs. Wild animals should only be taken from their natural habitats if captive bred animals are unavailable. Best scientific and teaching practice should be employed under the direct supervision of a competent person. Projects should be designed to avoid both pain and distress, and if this is not possible, pain or distress must be minimised. Alleviation of such pain or distress must take precedence over completing a project. If this is not possible the animal must be euthanased without delay.

Responsibilities of institutions

Research institutions and universities that use animals for scientific purposes are responsible for the implementation of processes that ensure compliance with the particular code and legislation of the country concerned. It is expected that most of these institutions have processes that:

- Ensure that researchers and teachers are provided with details of the institution's policy on the care and use of animals, confidentiality, and their responsibilities.
- One or more AECs are established that are directly responsible to the governing body of the institution or its delegate for ensuring that all care and use of animals is conducted in compliance with the code. The AECs are responsible for the application of a set of principles, as outlined in the code, for the monitoring of people working with animals, and the approval of guidelines for animal care and use (including veterinary and diagnostic services).

Responsibilities of researchers and teachers

Researchers and teachers have a personal responsibility to ensure that all matters related to animal welfare are in accordance with all requirements of the code. This responsibility begins with the decision taken that an animal will be used in a project and ends with its fate at the completion of the project. Before any scientific activities commence, a proposal that elaborates on the design of the project showing compliance with the code and relevant legislation and information on participating parties should be submitted to the AEC. Researchers and teachers must also ensure that the personnel involved in animal care and management are competent and know what their responsibilities are and make sure that records on the use and monitoring of animals are maintained.

Planning and execution of projects

During the planning phase of a research project or any other activity involving animals a number of questions should be asked:

Do the potential benefits outweigh any ethical concerns about the impact on animal welfare?

Can the aims be achieved without using animals?

If an animal has to be involved, has the most appropriate species of animal been selected?

Is the biological status (including genetic, nutritional, microbiological, and general health) of the animal appropriate?

Are suitable animal holding facilities, equipment, and personnel available?

Are all involved personnel informed of the planned procedures and do they have the skills and experience to perform the procedures?

Has the project been designed so that statistically valid results can be obtained or educational objectives achieved using the minimum number of animals?

Is the potential impact on the selected animals known? If not, should a pilot study not be included to assess the impact on animal welfare?

Does the project ensure minimum adverse impact on animal well-being?

Have arrangements been made to assess animal well-being on a regular basis?

If the investigation is not the first of its kind, why is the work being repeated?

Have all relevant permits been obtained (including those for the importation, capture, use, treatment, humane killing, or release of the animals)?

What arrangements have been made for the fate of all healthy animals at the completion of the *project*?

Will animal suppliers be able to provide documentation of the biological status of the animal?

Genetically modified and cloned animals

Most codes of practice recognise that the potential impact of genetic modification on the welfare of animals raises special concerns. Therefore, most codes make specific recommendations on how best to manage the potential impact of genetic modification on the welfare of animals and the associated monitoring requirements. Because genetic modification may require specific welfare needs throughout the lifespan of these animals and into subsequent generations, codes often include the cloning of animals, as all these animals require special needs.

These codes offer advice on dealing with the 3Rs, husbandry, record keeping, and unexpected phenotypic expression as they apply to genetically modified and cloned animals. A proposal of a project submitted to an AEC that involves genetic modification of animals should provide details on the following:

- The reason for creating the genetically modified animal
- The potential impact of introducing a new gene, or altering the expression of existing genes on all the animals involved in the project
- Any potential side effects of genetic manipulation that may impact in a negative way on the welfare of the parent animal or offspring
- Details on monitoring procedures of unexpected adverse effects arising from the genetic modification
- Suggestions of how to deal with animals that suffer adverse effects
- In the event of animals suffering pain or distress, details of specialist care that will minimise the negative effects

- Breeding procedures if a breeding colony is to be established
- Techniques used for tissue collection for genotyping
- The fate of those animals that do not have the required genotype
- Definition of humane killing

The cloning of animals may or may not involve genetic modification. A project proposal should include the details of the cloning procedure, as cloning by somatic cell nuclear transfer technique may be associated with unexpected adverse effects. Most codes strictly prohibit the combination of human and animal gametes.

AECs usually expect regular reporting on any adverse side effects that the animals might suffer. Regular reporting on these animals mortality, morbidity, population health, adverse side effects including the stability of the phenotype of the animals over several generations is also expected.

Ethical approval, access, permits, and legislation

Ethical approval

In agricultural research institutional and governmental principles, codes, regulations, and policies (including policies on misconduct) guide the practice of scientific research. These guidelines vary from country to country. They are like a set of useful rules, but do not cover every situation that arises in research. As these guidelines often conflict they require considerable interpretation, thus researchers should learn how to assess, interpret, and apply various research rules and how to make decisions about how to act in different situations.

Each research institution or university has committees or boards that are involved in the regulation of the research process that function within boundaries defined by institutional rules and legislations at regional, national, and international levels. Examples of such committees are: University Research Committee, University Ethics Advisory Group, Animal Ethics Committee and School Research Committees. Researchers should be fully informed about what committees exist in their institutions, what their respective functions are, and obtain the guiding rules for research to confirm compliance of their projects.

In agricultural research, ethical approval is often only required for projects that involve animals, however, some universities and research institutions, require approval for all projects. Ethical approval requires that an application form is completed in writing which may cover the following points listed in Box 2.

Intellectual property (IP) is regarded as a legal matter by most institutions that conduct research. Research offices will provide the guidelines on IP and facilitate the signing of agreements on IP. It is important that researchers ensure that these agreements are signed before the commencement of research. This also applies for bilateral and multilateral research agreements between countries.

Access, permits, and legislation

Researchers in agriculture often need access to genetic resources, either within their own country or in other countries. Therefore, although not the primary

Box 2. Form to be submitted to AEC

1. The project title.
2. The expected commencement and completion dates.
3. The names of all personnel involved with the project, their role, and details of their experience and qualifications.
4. The source of animals and permits if required; details of animal housing arrangements.
5. Aims and potential benefits of the project.
6. Outline of the project design in relation to its aims.
7. Justification for the use of animals in the project.
8. Detailed descriptions of procedures.
9. Aspects that relate to Reduction:
A clear description of:
 - The number, species, and strain of animals required
 - The reasons why this number is necessary
 - Whether there is an opportunity for the sharing of tissues or animals
10. Aspects that relate to Replacement:
Explanation of why animals are needed for the project.
11. Aspects that relate to Refinement:
Proposals must identify and justify the impact of all aspects of the project on an animal's well-being from the time it is obtained until the project is completed and detail how that impact will be minimised.
This will include:
 - Step-by-step description of what will happen to each animal during the project
 - Arrangements for the animal or animals at the completion of the project, including, if applicable, the method of humane killing
12. Monitoring procedure of animals.
13. Most proposals include a statement signed by the responsible researcher(s) or teacher(s) stating that they and all others involved in the project are familiar, and will comply, with relevant requirements of the code and legislation.

focus of this discussion, some mention of international agreements and legislation regarding the access and use of genetic resources is desirable. Historically, genetic material was generally freely collected and shared. Over many years of research, the developing countries with their wealth in biological biodiversity have been a major source of genetic material to many countries conducting research in agriculture. However, today, unrestricted access to germplasm without benefit sharing is regarded as an inequitable system of exchange.

A wide range of options for exchange of genetic material is available, from a strictly bilateral approach at one extreme to an unstructured informal multilateral approach at the other extreme, with a multitude of additional options in between. An exclusive bilateral arrangement is likely to be complicated given complex negotiations and uncertainties regarding the financial benefits that might accrue. At the other end of the spectrum lies an approach which characterises the current informal exchange system which has been responsible for much of the food crop germplasm collected and exchanged internationally over the last two decades and has benefited both developing and developed countries. Negotiations with

unrestricted access may simply require collection permits and phytosanitation documents. Unfortunately unrestricted access to genetic resources has led to the exploitation of many developing countries' biodiversity.

The Convention on Biological Diversity (CBD), established in 1992, seeks to initiate a process that will lead to a transition from an exploitative and inequitable relationship between providers of biodiversity and its users to one of facilitated access and benefit sharing. Governments that signed this convention, committed themselves to creating policy and legislation to simultaneously regulate and facilitate access to genetic resources (AGR) in the interest of three inter-related goals: biodiversity conservation, sustainable economic development, and socio-economic equity. Subsequent to the CBD, the International Treaty on Plant Genetic Resources for Food and Agriculture (TRIPS) (2004) came into force to facilitate access and benefit sharing, reducing transaction costs, and regaining some aspects of common access and use.

Project design, data collection, and data analysis

To preserve the integrity of research, researchers are obliged to report honestly, objectively, avoid error, and disclose all important information. Objectivity in research gives researchers trustworthiness. This applies to both the a-priori tasks of setting up the research and gathering the data and in the a-posteriori tasks of interpreting and publishing the results. This is critical so that future work built on the research will continue in an objective fashion. The socialist Robert Merton published four norms of science in 1973 that are widely shared by scientists and non-scientists alike. These norms are:

Universalism that stipulates that scientific accomplishments must be judged by impersonal criteria

Communism (as in communalism) that requires that scientific information is shared publicly

Disinterestedness that cautions researchers to proceed objectively

Organised skepticism that requires that new findings be scrutinised through peer review, replication, and the testing of rival hypotheses

It is of growing concern how often research integrity is being challenged, and how common “unprofessional” behaviour seems to be in research today. Researchers knowingly or intentionally ignore some of the most fundamental rules of research. Experimental designs and analyses are biased, results are reported inaccurately or incompletely or are fabricated, and improper credit is given to colleagues.

Project design and data management

In project design and data management the three issues of ethical concern are: the ethical and truthful collection of reliable data; the ownership and responsibility of collected data; and retaining data and sharing access to collected data

with colleagues and the public. Addressing these issues can be time consuming and are often overlooked by researchers, who assume that they can “figure it out” as they go along. However, to ensure accurate reporting of research results, researchers are required to plan a project carefully, keep clear and complete records of data, which should be sufficient enough so that replication of the research is possible.

Today computers are extensively used in data recording, which allows for easier alteration of data. This emphasises the importance for senior researchers and supervisors to mentor young researchers in the rules of ethical and responsible research to data recording.

Good planning of a research project will give good results. It is often helpful to enlist the inputs of a statistician in the planning phase to facilitate the organisation of ideas into a logical analytical framework thereby increasing the statistical power of the test(s) associated with the experiments. Although planning does not ensure success, it does prevent biases that could result from poor experimental design. Good planning can prevent costly waste of resources, difficult statistical analyses, data for which interpretation might be controversial and an experimental design that answers the wrong questions. When developing the research hypothesis, it must be formulated so that it clearly relates to the problem to be solved and should be stated as simply as possible. Research methods, including statistical treatments, should be clearly described and referenced.

Responsible and reliable collection and management of data require that the following be taken into account during the design and management of a new project:

1. The person in charge of project design and data collection should be identified, usually the principal scientist of the project.
2. How the data will be collected. Data should be recorded as they are generated, explicitly labelled and dated.
3. How the data will be stored and what privacy and protection issues are to be taken into account. Secure storage of data preserves the integrity and privacy of data. Printouts from instruments and computers should be appropriately labelled and filed. Data sets should be stored either as hard copy or on disks with carefully documented definitions for codes used in the data sets.
4. How the data will be analysed and interpreted forms a large part of the project design process.

Data analysis

In agricultural research most research questions are quantitative in nature, less frequently qualitative. Quantitative queries can be put in the form of a test of significance, while qualitative questions may not fit into the test of significance paradigm easily, which should be kept in mind when designing a research project. It is the responsibility of researchers to acquaint themselves with the relevant quantitative methods for processing data, including graphical and tabular methods of presentation, error analysis, and tests for internal consistency.

The importance of good statistical planning cannot be emphasised enough. It is important to address the statistical issues before experimentation or tests, because once one has gathered and recorded data, it may be too late to correct statistical (or ethical) flaws in the design of the experiment. A great variety of different statistical methods can be used to analyse data. Researchers should ensure that statistical methods are used correctly so as to avoid conclusions that may overestimate or underestimate a relationship or effect.

While researchers acknowledge that the proper use of statistical methods is a critical element of research integrity, there has been considerable debate on the subject of misuse of statistics in research. Misuse of statistics occurs when statistical methods, techniques, or models are used in ways that produce distorted or artificial results or when researchers fail to disclose information about statistical methodology. Although some cases of misuse of statistics can be considered as unethical (misconduct), most should be viewed as negligence or deficits of competence. Supervisors are therefore tasked to ensure good statistical practice, which can be defended when challenged, and if inappropriate, should be corrected. Poor statistics leads to poor science.

Responsible and reliable analysis of data can be obtained when the following are considered. This is by no means a review of the *dos and don'ts* in statistical practice, but an attempt to demonstrate the need for honest and reliable data analysis.

1. Skewed questions that could render data faulty and off the mark should be avoided.
2. Professionalism requires adequate application of both statistical and subject matter expertise to analyses. A researcher who makes excessive errors due to haste, ignorance, or sloppiness may be considered to be negligent or lacking the needed degree of competence. However, honest error is not regarded as misconduct.
3. Statistical issues such the exclusion of outliers, imputing of data, editing of data, "cleaning" of data, or "mining" of data should be addressed during the planning phase and reported honestly.
4. Statistical methodology should be applied correctly so as to minimise noise and produce a clear signal without distortion.
5. Depending on what is customary for your discipline, either all the data points or all the means need to be reported and if there are values not included, the reasons for so doing need to be disclosed.
6. If data points are trimmed, removed from the data set, there should be a justifiable reason why these data points are not representative of the entire data set and should be reported as such.
7. Data that contradict or fail to support the conclusions or confounding factors should be reported. Withholding such information is considered a breach of research integrity.

ETHICS ISSUES THAT PERTAIN TO THE TRANSFERRING PHASE OF THE RESEARCH PROCESS

Ethical obligations of authors

It is a researcher's obligation to publish results of research so that readers may be informed and are able to build on the reported findings. The methods and results should be sufficiently and accurately detailed with an objective discussion of its significance, so as to allow replication.

Criteria for authorship

Recently, research has become much more collaborative. Researchers work with colleagues at different stages in their careers, in different disciplines, or even in widely separated locations, which has resulted in an increase in the number of participants in a research project and potential authors of manuscripts that flow from the work. This has brought about many questions of authorship. Division of credit should be discussed openly and frankly early in the research process, preferably at the very beginning.

Fair recognition of participants in research projects is given through proper allocation of credit is acknowledged in three places in a scientific publication; in the list of authors, in the acknowledgements of contributions from others, and in the list of references or citations.

The decision of which names are listed as co-authors should reflect the relative contributions of the various participants in the research and should only be listed with the knowledge or permission of the authors. There is general agreement that only persons who have significantly contributed to the research or project and manuscript preparation shall be listed as co-authors and they should be prepared to defend the publication against criticisms. Often journals, research institutes, and universities require a signed statement attesting to having read and approved the final manuscript. It is also important to name all co-authors in oral presentations, especially when abstracts of the proceedings of a conference at which a paper is presented will be published. Entitlement to authorship should be the same whether or not a person is still at the original location of the research when a paper is submitted for publication. Listing of so-called honorary authors as co-authors should be avoided if they do not meet the criteria for authorship.

The listing of co-authors can be particularly sensitive when it involves scientists at different stages of their careers, such as young graduates or senior faculty. Differences in roles and status compound the difficulties of awarding authorship. Senior scientists are well aware of the importance of credit in science and are expected to give junior researchers credit where warranted. The criteria applied in these situations are varied. Generally, if a senior researcher has defined and put a project into motion and a junior researcher invited to join, major credit may go to the senior researcher, even if at the moment of

discovery the senior researcher is not present. Conversely, when a student or research assistant has made an intellectual contribution to a research project, such a contribution deserves recognition. A corresponding, or senior author should be designated for every paper, which will be responsible for communicating with the publisher and for informing all co-authors of the status of review and publication.

Order of authors

Conventions about the order in which co-authors' names appear differ greatly among disciplines and among research groups. In many research fields, the earlier a name appears in the list of authors, the greater the implied contribution. Sometimes the scientist with the greatest name recognition is listed first, whereas in other fields the research leader's name is always last. In some disciplines supervisors' names rarely appear on papers, while in others the professor's name appears on almost every paper that comes out of the research laboratory. On the other hand, to avoid these decisions, some research groups simply list authors alphabetically. Whatever the discipline, it is important that all co-authors understand the basis for assigning an order of names and agree in advance to the assignments.

Citations

Citations are part of the reward system of science and serve many purposes. They place a paper within its scientific context, relating it to the present state of scientific knowledge. They also acknowledge the work of other scientists and direct readers to additional sources of information. Scientists, who fail to cite the work of others, undermine the incentive system for publication and may find themselves excluded from the fellowship of their peers. In addition, researchers who are open, helpful, and full of ideas become known to colleagues and will benefit more than those that are secretive or uncooperative. Authors should not imply unwarranted status of own unpublished work. However, a paper may be listed as submitted if a galley proof, or a page proof, or a letter from the editor or publisher stating that publication has been approved, has been received.

Acknowledgements

Participants in the research process, who were responsible for the acquisition of funding, or general supervision of the research group, by themselves, do not justify authorship. These colleagues should instead be acknowledged at the end of a paper with a brief description of their contribution, with their consent.

Publication

In most fields of research it is unacceptable for an author to submit for review more than one paper describing essentially the same research to more than one journal. This practice is referred to as self-plagiarism. Also, fragmentation of

research into numerous papers should be avoided. Release of research findings should be via professional peer-reviewed journals.

Plagiarism

The act of plagiarism of the work of others brings into question the integrity, ethics, and trustworthiness of the researcher and is both illegal and punishable. The original source should be cited if the actual words of another person is quoted, orally or in written form; another person's words are paraphrased, orally or in written form; another person's ideas, opinions, or theories are used; or when facts, statistics, or illustrative material, are borrowed, unless the information is common knowledge. Most authors do not intentionally plagiarise. However, because authors consult a variety of sources of information for their research, they end up amalgamating this information with their own. Therefore, to avoid unintentional or accidental plagiarising the following guidelines are useful:

- Authors should cite all ideas and information that is not their own and/or is not common knowledge.
- Authors should use quotation marks when using someone else's words.
- Authors should use an appropriate citation to indicate a section that is paraphrased.

Peer review

Publication of research involves the review of research results by independent scientists, the independent self-regulatory system of the scientific community. Deliberately avoiding peer review for personal gain may constitute professional misconduct. All scientists have an obligation to participate in the process. As the review process happens before a paper is published the content must be kept confidential. Reviewers must disclose conflicts of interest resulting from direct competitive, collaborative, or other relationships with any of the authors, and avoid cases in which such conflicts preclude an objective evaluation. Reviewers should judge objectively the quality of the research reported and respect the intellectual independence of the authors, not give personal criticism, point out relevant published work that has not been cited, and call to the editor's attention any substantial similarity between the manuscript under consideration and any published paper or manuscript submitted concurrently to another journal.

Communicating with the funders/sponsors and the public

Funders/Sponsors

Generally, written agreements with funding agencies are encouraged wherever possible, so as to avoid damaging confrontations and to maintain good relationships. Clarification of the respective obligations of funders and researchers and their institutions should be obtained before commencement of research. Many research institutions and government agencies have started to adopt explicit

policies to reduce conflicts over such issues of ownership and access of scientific knowledge. Researchers should avoid agreements that emphasise speed and economy at the expense of good quality research, and also avoid, where possible, restrictions on their freedom to disseminate research findings. In turn, it is hoped that funding agencies will recognise that intellectual and professional freedom is of paramount importance in the scientific community and support the dissemination of research findings without much delay. With regard to research that is potentially profitable, openness can be maintained by granting patents, which enable a researcher or institution to profit from scientific research in return for making the results public. In these situations, researchers have special obligations to the funding agency of that work.

Public

Researchers should avoid announcing research results or discoveries to the public before their work has undergone peer review. When results need simplification because they are too technical or complex to be understood by the lay public, the following guidelines should be followed when communicating with the public:

- Overselling should be avoided.
- Unsupported claims should not go unchallenged.
- Technical details must be available at the time of any public announcement.
- Providing inflated titles/names for the research work should be avoided.
- Communication guidelines of your institution should be followed if they exist.

CONCLUDING REMARKS

Innovative research in all biological sciences has in the past few decades led to the development and application of exciting new technologies. This did not happen without being challenged on many ethical fronts and has brought into focus the need for the maintenance of research integrity and the constant evaluation of ethical norms. Rigour and honesty can unfortunately no longer be the only consideration, as in areas such as biotechnology in agriculture, ethical bias can be hidden within evaluation methodology itself. Also, the need for consideration of the socio-economic and environmental impact has now been recognised as an integral part of research planning. Even the assiduous and objective researcher might fail to identify issues where the end products of scientific innovation create problems with respect to collaborators, the community, and environment.

Research should be conducted and reported with honesty, accuracy, respect for the rights of others, fairness, and objectivity. To achieve this, mechanisms that ensure integrity in the research process should be put into place to handle allegations of misconduct. In the light of growing demands and incentives for financial gain in the research environment, responsible research conduct is called for. Approaches that protect and enhance knowledge of scientific traditions and sound research practices and the punish-

ment of misconduct should be introduced in all places of research. Thus, accountability in scientific research activities at an institutional level and through self-regulation is imperative.

Lastly, the need for formal education in ethics in agricultural research has not been more relevant. Universities are tasked with familiarising young and upcoming scientists with the rules of sound and ethical scientific research.

ACKNOWLEDGEMENTS

To the many anonymous authors that made their ideas and thoughts unselfishly available on the internet, my sincere thanks. They provided many hours of pleasurable reading.

BIBLIOGRAPHY

- Anderson, T.R. 2005. The effective practice of agricultural science. In: Van Niekerk, A. (ed.), *Ethics in Agriculture – An African Perspective*. Springer, Dordrecht, The Netherlands.
- Australian Government, Animal Welfare Committee. National Health and Medical Research Council. 2005. Guidelines for the generation, breeding, care and use of genetically modified and cloned animals for scientific purposes. <http://www.nhmrc.gov.au/consult/gmguidelines.htm>
- Australian Government. 2004. Australian code of practice for the care and use of animals for scientific purposes, 7th edn. <http://www.nhmrc.gov.au/publications/synopses/ea16syn.htm>
- Beever, D.E., and Kemp, C.F. 2000. Safety issues associated with the DNA in animal feed derived from genetically modified crops. A review of scientific and regulatory procedures. *Nutrition Abstr. Rev., Series A: Human and Experimental*, 70: 197–204.
- Biotech Pty Ltd. 2006. Draft on minimising pain, distress and suffering in animals in research. Canberra, Australia. http://www.research.utas.edu.au/animal_ethics/docs/nhmrc_draft_pain_and_distress.pdf
- Burkhardt, J. 1998. The inevitability of animal biotechnology? Ethics and the scientific attitude, In: Holland, A. and Johnson, A. (eds.), *Animal Biotechnology and Ethics*. Chapman & Hall, London.
- Cullet, P. 2001. Property rights regimes over biological resources. International Environmental Law Research Centre, International Environmental House, Chemin de Balxert 7 & 9, 1219 Châtelaine. <http://www.ielrc.org/content/a0104.pdf>
- Coetzer, T., and Goldring, D. 2005. Animal rights and animal welfare. In: Van Niekerk, A. (ed.), *Ethics in Agriculture – An African Perspective*, Springer, Dordrecht, The Netherlands.
- Columbia University. 1999. Access to genetic resources: An evaluation of the development and implementation of recent regulation and access agreements. Environmental policy studies working paper No. 4, School of international and public affairs, Environmental policy studies workshop, 1999, The tides center – Biodiversity action network.
- Damen, V., Adley, C., Brinkman, F., Hammelev, D., Johansson M., and van Strydonck, M. 1997. Transgenic plants. *Euro. Initiative Biotechnology Education*, (EIBE), Unit 9.
- Etherton T.D., Bauman, D.E., Beattie, C.W., Bremel, R.D., Cromwell, G.L., Kapur, V., Varner, G., Wheeler, M.B., and Wiedmann, M. 2003. Biotechnology in animal agriculture: An overview. *Counc. Agricul. Science Techn. (CAST), Issue Paper No. 23*, West Lincoln Way, Ames, IA, 500014–3447.
- Ethical Evaluation of Research in Finland. 2002. Printing House Snellman Ltd., Helsinki. <http://www.protsv.fi/tenk/EthicEval.pdf>
- FAO Ethics Series 2. 2001. *Genetically Modified Organisms, Consumers, Food Safety and the Environment*. Food and Agriculture Organization of the United Nations, Rome.
- FAO Ethics Series 3. 2004. *The Ethics of Sustainable Agricultural Intensification*. Food and Agriculture Organization of the United Nations, Rome.

- Fossey, A. 2005. Agricultural biotechnology. In: Van Niekerk, A. (ed.), *Ethics in Agriculture – An African Perspective*, Springer, Dordrecht, The Netherlands.
- Gardner, J.S., and Resnik, D.B. 2001. The Misuse of Statistics: Concepts, Tools, and a Research Agenda. *Proc.: Investigating Research Integrity*.
- IPGRI. 1996. Access to Plant Genetic Resources and the Equitable Sharing of Benefits: A contribution to the debate on systems for the exchange of germplasm. *Issues in Genetic Resources No. 4*, International Plant Genetic Resources Institute, Rome.
- Kinderlerer, J., and Adcock, M. 2003. Agricultural Biotechnology, Politics, Ethics, and Policy. Sheffield Institute of Biotechnological Law and Ethics, University of Sheffield, Working paper No. 3, Prepared for the first meeting of the FANRPAN/IFPRI, Regional Policy Dialogue on Biotechnology, Agriculture, and Food Security in Southern Africa, Johannesburg, South Africa.
- Korthals, M., and Bogers, R.J. (eds.). 2005. *Ethics for Life Scientists*, Vol. 5. Springer, Wageningen, The Netherlands. Ur Frontis Series.
- Macquarie University. 2005. Macquarie University Intellectual Property Policy. Sydney, Australia, *Draft document filename: MQ Framework - IP Policy Main - 2005 ver 1–08*
- Module II, Responsible Authorship and Peer Review. Research ethics mini rounds, A series of modular study units, NC State University. http://www.chass.ncsu.edu/ethics/inst_mod/authorship.pdf
- Module IV, Animal Subjects in Research: An Overview. Research ethics mini rounds, A series of modular study units, NC State University. http://www.chass.ncsu.edu/ethics/inst_mod/animal_subjects.pdf
- Module V, Professional Responsibility and Codes of Conduct. Research ethics mini rounds, A series of modular study units, NC State University. http://www.chass.ncsu.edu/ethics/inst_mod/professional_responsibility.pdf
- Module VII, Right doing and Misconduct in Research: An Overview. Research ethics mini rounds, A series of modular study units, NC State University. www.tele.sunyit.edu/rightdoing_and_misconduct_in_research.pdf
- Module X, Science and the Media: Ethical Issues, Uncertain Ground: The Boundary Between Science and the Press. Research ethics mini rounds, A series of modular study units, NC State University. www.fis.ncsu.edu/Grad/ethics/modules/science_media_ethical_issues.pdf
- Module IX, Responsible Use of Statistical Methods Identification of Outliers in a Set of Precision Agriculture Experimental Data. Research ethics mini rounds, A series of modular study units, NC State University. www.chass.ncsu.edu/ethics/inst_mod/ethical_issues_in_statistics.pdf
- National Academy of Sciences. 1992. Ensuring the Integrity of the Research Process (Free Executive Summary). Panel on Scientific Responsibility and the Conduct of Research, National Academy of Sciences, National Academy of Engineering, Institute of Medicine Responsible Science. <http://www.nap.edu/catalog/1864.html>
- Niels, L. 2006. Ethics watch: Controls over plant genetic resources — A double-edged sword. *Nature Reviews Genetics* 7: 241, doi:10.1038/nrg1833.
- Nuffield Council on Bioethics. 2005. The ethics of research involving animals. Nuffield Council on Bioethics, 28 Bedford Square, London C1B 3JS. <http://www.nuffieldbioethics.org>
- Persley, G.J., and Siedow, J.N. 1999. Applications of Biotechnology to crops: Benefits and risks. Council for Agricultural Science and Technology (CAST), Issue Paper No. 12, West Lincoln Way, Ames, IA, 500014–3447.
- Potter, V.R. 1970. Bioethics: the science of survival. *Perspective in Biology and Medicine*, 14: 127–153.
- Resnik, D.B. 2006. What is Ethics in Research and Why is It Important? National Institute of Environmental Health Sciences (NIEHS), Bioethics Last Revision.
- Robinson, J. 1999. Ethics and transgenic crops: A review. *Electronic Journal of Biotechnology* 2 (2). <http://www.ejb.org/content/vol2/issue2/>
- Rollin, E.R. 1995. *Farm Animal Welfare: Social, Bioethical and Research Issues*. Iowa State University Press, Ames, IA.
- Rudacille, D. 2000. *The Scalpel and the Butterfly: The War Between Animal Research and Animal Protection*, Farrar, Straus & Giroux, New York.

- Schroder, B., and Muschamp, D. 2000. Developing an Agribusiness Ethics Curriculum. Paper presented to: The International Management Agribusiness Association Forum Chicago.
- Shelton, A., McCandless, L., Lewenstein, B., Hawkes, J., Lyson, T., Bauman, and Aldwinckle, H. 2002. *Agricultural Biotechnology: Informing Dialogue*. College of Agriculture and Life Sciences, New York State Agricultural Experiment Station Geneva, NY; Cornell University Agricultural Experiment Station, Ithaca, NY. <http://www.nysaes.cornell.edu/comm/gmo/PDF/GMO2002.pdf>
- Snustad, P.D., and Simmons M.J. 2003. *Principles of Genetics*. Wiley, New York.
- Steneck, N.H. 2005. Five Ways to Promote Responsible Research through Graduate Education. Commentary: Research Ethics and Ethical Issues, Office of Research Integrity, University of Michigan, OH.
- Straughan, R. Ethics, Morality and Animal Biotechnology. The Biotechnology and Biological Sciences Research Council (BBSRC), Polaris House North Star Avenue, Swindon SN2 1UH, UK. http://www.bbsrc.ac.uk/tools/download/ethics_animal_biotech/ethics_animal_biotech.pdf
- Tamarin, R., and Leavitt, R.W. 1991. *Principles of Genetics*. Wm. C. Brown Publishers, Dubuque, IA.
- The postgraduate foundation in veterinarian science of the University of Sydney. 2000. *Animal Breeding: Use of New Technologies*. A textbook for consultants, farmers, teachers and for students of animal breeding. CRC, Twynam.
- Thompson, P.B. 2004. Research ethics for animal biotechnology, Korthals, M. and Bogers, R.J. (eds.), Workshop in 2003 of group of experts in the ethics of life sciences, Wageningen, The Netherlands.
- University of Minnesota, Center for Bioethics. 2003. *A Guide to Research Ethics*.
- Wallace H.A. 2000. *Transgenic Crops: An Environmental Assessment*. Centre for Agricultural and Environmental Policy, Winrock International.
- Wikipedia, the free encyclopedia. 2006. Animal rights. http://en.wikipedia.org/wiki/Animal_rights
- Wikipedia, the free encyclopedia. 2006. Bioethics. <http://en.wikipedia.org/wiki/Bioethics>

CHAPTER 8

THE CONTRIBUTION OF INFORMATION AND COMMUNICATION TECHNOLOGIES (ICT) TO THE MANAGEMENT OF PUBLICLY FUNDED AGRICULTURAL RESEARCH

E. GELB¹ AND D. LEVANON²

¹Former CIO, Israeli Ministry of Agriculture and Rural development; ²Chief Scientist, Israeli Ministry of Agriculture and Rural Development

INTRODUCTION

Efficient management of public funds is an unending endeavor. Efficient management of publicly funded agricultural research is no exception. Information and Communication Technologies (ICT) are tools to this end. Unfortunately, studies that specifically quantify ICT's contribution to the methodology of research management, research effectiveness, dissemination of research results, and feedback to enable research prioritizing are impoverished in empirical details and economic results. Management of publicly funded agricultural research again is not an exception. Regardless, the purpose of this review is an attempt to enhance the understanding of the contribution and impact ICT had and has on the management of publicly funded agricultural research. Hopefully, it will elicit future empirical work to quantify ICT's contribution to research management, improve ICT's effectiveness, and provide pointers for prioritizing essential research in the future.

The term "Information and Communication Technologies" (ICT) is a term in evolution. It currently includes a multitude of technologies, methodologies, and services dealing with data, information, and knowledge – their generation, management, dissemination and feedback, adoption and implementation, development of ICT themselves, innovations, their use, and more as the technologies and methodologies diversify, multiply, and conquer.

Four major aspects in effect dictate research management's ICT dependence: increased knowledge, paradigm shift, recognition of economic stimulus and collaborative, multinational interdisciplinarity. These in turn lead inexorably to the need for ICT supported systems to assist researchers, administrators,

strategists, opinion-formers, entrepreneurs, innovators, and the general public. These systems are needed to provide both information for decision-making and support to the process of knowledge-creation Zimmerman (2006). ICT and ICT supported systems have become indispensable.

WHAT IS ICT?

The term ICT is a first-generation descendent from the term “Information Technologies” (IT) coined with the arrival of the Internet, broadband connections, and their application to IT methodology. They are both derivatives from defining our times in terms such as the Information Society (IS), the Knowledge Economy (KE), the Postindustrial age, and more.

ICT currently includes a multitude of technologies, methodologies, and services dealing with data, information, and knowledge – their generation, management, dissemination and feedback, adoption and implementation, development of ICT themselves, innovations, their use, and more as the technologies and methodologies diversify, multiply, and conquer. One formal definition is by the OECD in “Measuring the Information Economy”. It details one set of definitions of ICT “goods” in its review of the history of international efforts to standardize definitions as follows: *ICT goods must either be intended to fulfil the function of information processing and communication by electronic means including transmission and display or use electronic processing to detect, measure and/or record physical phenomena or to control a physical process.*

Wikipedia defines Information Technology (IT) or Information and Communication Technology (ICT) as: *... a broad subject which deals with technology and other aspects of managing and processing information, especially in large organizations. In particular, IT deals with the use of electronic computers and computer software to convert, store, protect, process, transmit, and retrieve information.*

Scientists are not the only players in the ICT environment. The partners involved and interacting in the ongoing conceptualization, development, and implementation of ICT in general and specifically for management of research and agricultural research are many. They include ICT and subject matter scientists, end users (a definition which includes all involved – from farmers to basic research scientists), ICT service providers, the public at large, and all associated professionals and laymen. The communication component in ICT makes this ongoing interaction a uniquely efficient feature of our times. An example would be the Wikipedia definition of Bioinformatics – now at the forefront of scientific endeavor:

Bioinformatics and computational biology involve the use of techniques from applied mathematics, informatics, statistics, and computer science, and chemistry, especially biochemistry to solve biological problems usually on the molecular level. Research in computational biology often overlaps with systems biology. Major research efforts in the field include sequence alignment, gene finding, genome assembly, protein structure alignment, protein structure prediction, prediction of gene expression and protein-protein interactions, and the modeling of evolution ...

BACKGROUND

Support of Research Activity directed towards improvement of most forms of agricultural technology has long been recognized as a responsibility of the Public Sector, even in the most private-market oriented economies Boyce and Evenson (1975). Ruttan (1982) details agricultural research policy, the research review process, and the role of the research administrator. This role includes knowledge acquiring and funding effective research via monitoring within an overall research utility function. In several countries this is a formal public responsibility, often within Ministries of Agriculture. Perspectives guiding the research administrator are outlined by Boyce and Evenson (1975) “implicitly presuming that research and extension are productive activities that contribute to the efficiency with which scarce resources are converted to agricultural products”. Grilliches (1958) quantitatively estimated the contribution of such research to farm productivity. Evenson and Kislev (1975) survey in detail and quantify this productivity in the context of investment in agricultural research and extension. Alston et al. (1995) specifically indicate: “In a time of tight government budgets research administrators are faced with the need to provide strong evidence that costs are justified by benefits.” Eyal (1996) quantified this benefit suggesting a positive return ratio of 1:2.5 for public funding of agricultural research. The contribution and impact of innovative ICT to R&D management is illustrated within these generalizations in part via the publicly funded agricultural research in Israel and the role of the Chief Scientist in the Israeli Ministry of Agriculture. For a review of publicly funded agricultural research and the role of the Chief Scientist in Israel see Loebenstein and Putievsky (2007).

Public sector funding of advanced agricultural research and ICT supported research management is focused in this review on “developed countries”. By definition these countries, in this context, are characterized by capital intensive agriculture, utilization of modern technology, cutting edge science supported methodologies and minimal labor input. In order to achieve efficiency of public research in agriculture and attain its resulting productivity goals R&D management methodology employs uniquely complex interactions. This insight is universal. The interactions are dictated by extremely varied agricultural products and stakeholders. They range from environment maintenance to genetically modified crops, diverse research disciplines, various and heterogeneous stakeholders representing multiple and possibly conflicting interests and/or priorities with concerns and benefits spread over varying periods of time, regions, and markets.

Traditional management methodology to manage R&D in agriculture was and is supported by use of basic ICT, skillfully adapted and employed to do “traditional” clerical chores. Innovative research management methodology supported by ICT is considerably more complex. It involves coordinating interactive knowledge accessing, cross-referencing, and integration of ever-expanding and varied data sets, real time client feedback of research results and product

implementation, maintaining geographically neutral collaboration, synchronizing long-term goals with resource allocation priorities and much more. To the extent that in some cases R&D management methodology and practice are dictated by ICT specifics.

Exploiting innovative ICT supported management practices can substantially improve the efficiency of research, research results, and their dissemination and eventually result implementation. This efficiency can be expressed via an increase in general agricultural productivity, product quality, and technological progress (Levanon et al., 2005). Additional economic benefits can be derived from commercializing publicly funded/generated intellectual property rights (IPR), unique agricultural products, increased production output, marketing and management methodology, and more. Improved agricultural productivity contributes to rural viability and public welfare in general which in turn justifies public funding of agricultural research beyond the direct benefit to agricultural producers. The value-added contribution of ICT, over and above the subject matter contribution, in this context lies mainly in the efficient realization of these benefits. Illustrative examples are the spillovers from ICT adoption in rural areas (Gelb et al., 2003).

The importance of such public investment in ICT for agriculture was recognized at a recent conference of the European Federation of Information Technology in Agriculture (EFITA) Gelb and Parker (2005). The importance of incorporating ICT into the publicly funded research management procedures is universally recognized to the extent that specific programs are outlined for that purpose. A representative example is a program initiated by the Research Office for Research Information Management at the University of Sydney. The purpose of the ICT initiative Research Management Systems Project (RMSP) was to promote the following:

- Improve accessing information, information management, reporting, analysis, and enable assessment of quality and impact.
- Increase research income resulting from improved awareness of opportunities and income management.
- Reduce risk of data inaccuracy and improve data integrity.
- Ensure compatibility with future trends in Research Information Management, database, web and workflow technologies.
- Reduce costs by reducing manual processes, paperwork, and system maintenance.
- Support end-to-end research management.

The specific project objectives were to:

- Redefine the business processes to adhere as far as possible to best practices including electronic workflow, e-records management, paper management.
- Conduct a gap analysis of the business requirements across the potential vendors and products.
- Rationalize the recommendation for the best-fit vendor and product.
- Implement the Research Management System without negative impact to business operations.

- Reduce data redundancy and manual data handling.
- Improve data security, confidentiality, and privacy standards.
- Improve control and management of research financials.
- Improve technical platform to support open architecture and web-based options.
- Reduce the number of disparate and ad hoc systems across the University.

An additional example of expectations from ICT's contribution to research management on a larger scale is manifested in the European Union (EU) Financial Program (FP6). It has implemented the "European Research Area – Net" (ERA-NET) based on the potential and instrumental value of ICT adoption. The objective of the ERA-NET program is "to step up the cooperation and coordination of research activities carried out at national or regional level in the EU Member and Associated States through:

- The networking of research activities conducted at national or regional level and
- The mutual opening of national and regional research programs."

The ERA-NET program results are already contributing to EU research management. The European Research Area became a reality by improving the coherence and coordination across Europe of participating research programs. This enabled national systems to take on tasks collectively that they would not have been able to tackle independently. ICT provides support for trans-national networking and coordination of national and regional research programs. ICT is contributing by facilitating practical initiatives to coordinate regional, national, and European research programs in specific fields, pool-fragmented human and financial resources, and improve both the efficiency and the effectiveness of Europe's research efforts. Essentially ERA's target participants are program managers working in national ministries and funding agencies, and not necessarily individuals engaged in research and employed by universities or enterprises. Maoz (2006) describes the program and ICT's contribution to it via the Genomics ERA-NET details, currently at the cutting edge of agricultural research.

An additional aspect related to ICT supported tools for research management relates to Current Research Information Systems (CRIS). They are described by Zimmerman (2006) in the context of ICT supported systems as follows:

Internet-based digital information systems in science, as in all disciplines, today serve as the principal communication tool. This both obligates us and allows us to conform to international standards and best practices. Current Research Information Systems (CRIS) provide access to, and dissemination of, research information. ... There is a strong need for intelligent CRISs, and the Web search engines, powerful as they might be, are not a replacement for a good CRIS. CRISs should be used for decision-making at all levels, for the management of research activities, and for the dissemination of results. CRIS, in this respect, are the key for facilitating the processes of knowledge creation and management, and hence economic growth. ... The Common European Research Information Format (CERIF), developed by a group of experts sponsored by the European Commission, is a set of guidelines designed for everyone dealing with research information systems. It is designed to help in the development of new research information systems; to assist existing CRIS systems considering extensions and to guide CRIS systems on how to structure and index their data.

This reasoning is universal, with ICT in practice becoming indispensable for research management, with publicly funded research as well. The Wikipedia description of the term Bioinformatics quoted above indicates part of the complexity. This without adding the specifics of applied research and field applications and the inevitability of ICT's dominance in the field and managing.

Agricultural R&D in the “developed countries” of the world is to a large extent a public strategic concern due to Agricultural R&D market inefficiencies and the market's reflection on the general public – economic and social. This is the result of the fact that the total of private benefits of all firms is smaller than the overall public benefits (Alston et al., 1999). Consequently the investment in Agricultural R&D will be suboptimal without public sector funding. This market allocation inefficiency of funding for research has several causes. Two are dominant:

1. The products of Agricultural R&D are usually within the public domain. Examples include an overall reduction of pesticide applications or long-range planning criteria for using natural resources such as water and land, and many more. It is very difficult to patent the results of applied agricultural research and basic life sciences studies – a fact which deters private sector investments;
2. Technological innovation in agriculture deteriorates agricultural terms of trade – namely lowering the farmers' income from their products and increasing the cost of their inputs. It is the public that gains from this situation – better produce at lower prices and not the farming sector. In general since the public benefit is larger than the sum of benefits for the agricultural producers it stands to reason that it is within the public concern to sustain these trends. The agricultural producers are usually small and they cannot afford agricultural R&D. In this sense agricultural R&D is in essence different from industrial R&D carried out by firms that are the direct beneficiaries of the results. ICT availability and competence can compensate and in this case become a critical research management-enabling factor. Examples include regional, farmer-supported, research – which due to ICT competence can engage in local-specific, applied research – free from large institutional infrastructure constraints (Levanon et al., 2005 and the description of the Arava regional R&D below).

This description does not ignore the fact that agribusinesses (Large-scale farming and the Agricultural Inputs Industry) and concerns can be large. In fact to the extent that some of them have registered patents, “public” shareholders, multinational scope, etc. In many cases they are innovative and ICT intensive. They however are not “public welfare” oriented and they do not invest generally in public domain research. They do fund research in areas with potential IPR such as seeds, chemicals, fertilizers, etc. This is reflected in their share of the total funding of agricultural research but not to the extent that diminishes public funding dominance. A recent survey estimated their share in Israel at around 15% of the total agricultural R&D. This “private” ICT muscle dictates ICT-supported research management methodology making public–private research partnerships more effective and accessible.

An additional ICT residue from this relationship can be identified in the interaction with Governmental Research entities dedicated to agricultural research and complementing academic research institutes. Innovative ICT is supposedly integrated routinely in their activities. The academic teaching entities (universities) however do not have a binding commitment to management methodology of agricultural research and/or to agricultural productivity. Basic agricultural research in various areas conducted in University Faculties of Agriculture may not even be relevant in the short term, to current agricultural production. Examples include such “basic” ICT-intensive agricultural research areas including theoretical genetics, bioinformatics, cell biology, molecular physics along with their “applicative” aspects such as improving plant varieties with spliced-in genes, gene-specific pesticides, etc. As above, interaction with private ICT routine, ICT availability, and ICT competence could be expected to dictate research management methodology which indeed in turn becomes an enabling factor for regional, farmer-supported, research (Levanon et al., 2005). Two useful examples are the Danish Extension Service supported research activities, which include interacting with farmer cooperatives – undertaking at an early stage provision of ICT supported services and the Dutch agricultural research, which undertakes research for farmer associations. In the Dutch case the specific ICT components are incorporated in the general subject research. It is important to note here that neither governmental nor academic research entities necessarily formulate national research priorities or monitor them. The same is correct for their lack of responsibility for managing all the publicly funded agricultural research, and this, regardless of their competence with ICT enhanced tools.

ECONOMIC INDICATORS

With all this said, a quantitative evaluation of the ICT impact on the management methodology of publicly funded agricultural research and quantification of its efficiency is yet to be made. The following provides an indication of the economic results of ICT supported agricultural research management and the magnitude of returns.

A point to consider while evaluating ICT’s impact on the management of research is the agricultural sector’s size, its diversification, its comparative advantage in agricultural products, the local and export markets, and related technological innovations. Agricultural research in several small countries suggests that size is less important than export orientation. Examples include Denmark, Holland, and Israel. To be specific for example, Israel’s geographical and climate diversity result in Israel becoming a producer of a wide variety of products and a testing ground for ICT supported innovative production and marketing technology, technological innovations and novel/niche products for export. To sustain this advantage it is essential to maintain wide and comprehensive research capabilities able to address unique problems in the various areas of production and marketing with minimal lead times till implementation

of research results. This dictate is not unique to Israel and confronts other countries. A unique feature however is the participation of Israeli farmers and their representative organizations in funding the publicly funded agricultural research. Their funding participation is facilitated via fees levied by statutory marketing boards on marketed produce and regional funding by grower associations. Their priority choices are expressed in joint committees that allocate the “Public” funds according to overall needs and agreed criteria. The current composition of the committees is a three-way partnership – farmers, extension, and researchers – each in turn being a source of innovation, a stakeholder, and an end user of the research results. ICT supported facilities enable this close association and ongoing interaction. The review of the Arava regional R&D below outlines the details of such a regional research entity and the ICT component of its activities.

To be specific this framework is quite similar to the funding allocation practice in the United States and Western Europe. Gelb and Kislev (1982) evaluated the impact of farmers within this framework by detailing a series of committee allocations and the farmer’s point of view:

Agricultural research is mostly a public undertaking. In Israel, as in many other countries, farmers participate in the finance of research through taxes imposed by farm organizations on the marketed products. Farmer contribution ranges from 8% of research outlay in tomatoes to 79% in cotton. Strength of organization and ease of collection were the major factors affecting this share. In general, as inflation eroded the real value of government’s finance, the farmers increased their share.

Representatives of farmers’ organization participate in the bodies that approve grants to proposed research projects. It was found that the higher the share of farmers’ finance the larger the part of short-term research directed at immediate outcomes and the smaller the part of long-term, more basic research. The tendency of the farmers to prefer short-term, applicable research may reflect both their familiarity with practical problems and a comparatively high degree of risk aversion. It is not clear however, how farmers’ participation in the direction of research, which is based on their financial contribution, affects the efficiency of resource allocation to the agricultural science.

Table 1. identifies three ICT-based products resulting from this collaborative framework based on farmer initiation.

Table 1. Examples of ICT products and their funding

Product name	Type	Management methodology	Funding source	Net benefit
Afimilk	Management Information System (MIS)	Exception and deviation	Farmers	US\$200.00 cow/lactation
Phytek	MIS	Rates of deviation change	Farmers and Private	>10% irrigation efficiency
Wheat Disease Control Advisor	Expert System	Disease control Decision rules and recommendations	Farmers and Public	\$92.70/ha

Table 2. Overall benefit resulting from research

Crop	Innovative technology	Change %			Overall benefit
		Output	Labor	Capital	
Loquat	Early ripening	64.7	0.0	20.0	56.7
Avocado	More trees per area unit	77.0	45.2	61.1	25.4
Flowers	Sea transportation	14.6	0.0	0.0	14.6
Greenhouse	Roof cleaning	21.0	-14.3	29.6	17.8
Mushrooms	Agro technique	44.0	-5.0	16.1	40.6
Dairy	Economy of scale techniques	20.5	-20.0	5.3	30.9
Ornamental fish	Feeding management	32.3	12.0	4.0	23.5
Peanuts	Improved harvesting	30.4	-10.0	16.7	29.7

Source: <www.science.moag.gov.il/frameurma.html>, (Levanon et al., 2005)

Economic evaluation of public funding of agricultural research in general indicates a high rate of return Evenson and Kislav (1975). A more detailed review of Israeli funding for agricultural research with overall benefit resulting from it and its breakdown is presented in Table 2. (Levanon et al., 2005). Overall benefit was calculated using a Cobb-Douglas production function with labor and capital weighted at .60 and .40, respectively. The ICT components, including the cause-and-effect relationship, are detailed below.

Figure 1 details the average annual increases results of the publicly funded agricultural research measured at 8% between 1986 and 1990, 6.4% between 1991 and 1995, and 4.7% between 1996 and 2001. These rates were higher than those of other sectors of the economy (see Fig. 1). This rate of change in productivity in agriculture is due to rapid technological progress originating mainly from publicly funded agricultural research, development and adoption of the results with ICT's contribution detailed below (Bank of Israel, Research Department 1996, 2001 and Levanon et al., 2005).

Agricultural research in Israel contributed to the viability and development of the rural sector and public welfare. The public as beneficiaries were provided with high quality and affordable agricultural produce and other public goods derived from agriculture. These included environmental preservation, adopting agricultural practice to livelihood in areas of national priorities – arid lands, frontiers, and unique geography – an agricultural framework for high school education and rural viability. Agricultural innovations provided a basis for international scientific and economic collaboration, development of an agricultural input industry with profitable exports and additional employment. It is essential to note again Zimmerman's (2006) comments above regarding the research environment conducive to these results and ICT's dominant contribution as an enabling factor.

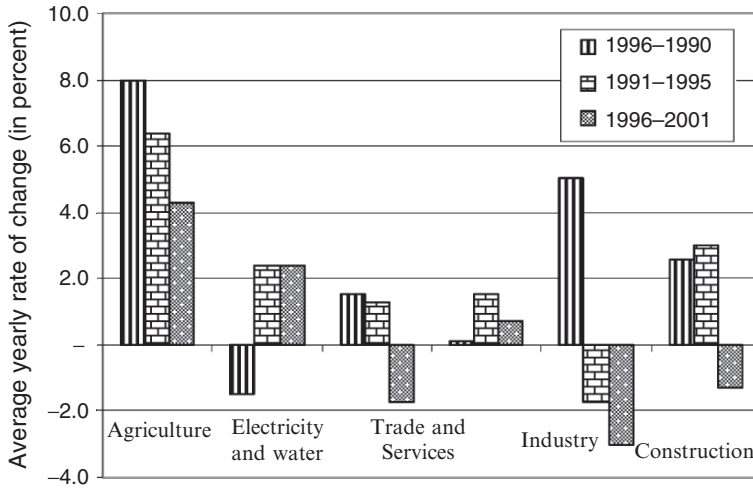

Figure 1. Overall productivity in the years 1986-2001.

WHO DECIDES ICT ADOPTION PRIORITIES AND ICT ROUTINE?

Adopting technological innovation can be a daunting experience for the management of an organization. Adopting ICT as a tool for the management of publicly funded agricultural research is no exception. In the context of this review it is important to consider the adoption process in terms of who decides what ICT are suitable – if there is a decision to adopt them, how to ingest ICT into the decision process, bridge the digital divide which in this case is the gap between the ICT literate and the rest of the individuals involved and how to keep the adoption process within budget, on time, and without disrupting the research routine. Major decisions involve the details regarding equipment, software, the limits of a “top-down” adoption approach, feedback within the organization and interaction with those outside, how to react to external pressure from research partners – private, public, and international, and more. The issues involved include a variety of organizational aspects, economics, interagency politics, social issues, public concern, regional, national and wider interactions, etc. Someone in the end has to make ICT adoption decisions.

One example of an organizational ICT adoption is described below. It details the role of the Israeli Chief Scientist in the management of publicly funded agricultural research. It is defined by a governmental decision, which indicates that: “The Chief Scientist is responsible to define the agricultural research priorities as guided by the Ministry’s goals. Specifically the Chief Scientist will have the ability to coordinate between the scientific community, other R&D entities, farmers and other sectors”.

The Chief Scientist is expected to identify the knowledge gaps that need to be addressed in order to achieve the Ministry's goals. Bridging these gaps is translated into the research goals and the methodology involved. A long-term overall research outline is defined and updated yearly. The Chief Scientist oversees the public funding procedures, and provides guidelines for public research priorities. Competitive bidding for allocation of public funds ensures effective allocation of resources. The Chief Scientist provides an impartial authority to guarantee this smooth interaction. Details of the system, ICT's contribution to it, and ICT adoption problems follow.

THE CONTRIBUTION OF INFORMATION AND COMMUNICATION TECHNOLOGIES (ICT)

ICT are today a major tool in managing public research – they are detailed below in context of the various stages of research management. They are integrated in all stages of research implementation and the reporting of research results to a wide range of users and beneficiaries. As mentioned above, there is a lack of economic evaluation of the direct ICT attributed benefits.

ICT supported teams led by the Chief Scientist facilitate the research program in the following general stages:

- Finalizing the research priorities and preparing the call for research proposals
- Collecting the proposals from scientists, regional research entities, regional councils, various organizations and individuals
- Monitoring the proposals and preparing them for evaluation
- Consolidating proposal evaluations for allocation decision
- Budgeting funds based on priorities and benefit/cost ratios
- Preparing the contracting of the approved proposals with necessary guidelines
- Allocating funds and financing the approved proposals
- Follow up of ongoing research to ensure compliance with its approved program
- Evaluation of research results and preparation of further professional recommendations, including possible updating and/or continuation research proposals

In detail the process involves the following sequence:

Formulation of research goals according to identified knowledge gaps – with participation of scientists, extension, farmers, economists, marketing professionals, and others. These are cross-checked against available results from various sources;

1. A call for participation – requests for submission of research proposals by “all involved in agricultural research in Israel” including researchers from ARO, Universities, regional research entities, regional councils, and others; at present the calls are available electronically

2. Processing of applications and proposals (several hundred a year) and their inclusion in the relevant information database
3. Evaluation of the proposals by a two-stage process:

The first stage entails assessment of the potential contribution to Israeli agriculture

The second stage entails an assessment of the scientific merit and success probability including *ex ante* economic analysis

This evaluation process involves hundreds of professionals: farmers, extension, scientists, other researchers, economists, planners, market professionals, and others. The process eventually prioritizes research proposals eligible for public funding. ICT provides the Chief Scientist with tools to independently follow all the above stages of the evaluation as they progress and in turn optimize the review recommendations in terms of expected agricultural productivity increase potential. It should be noted that the Chief Scientist's funding is primarily oriented toward "applied research" with "basic research" done mainly via the academic entities. Funding for basic research is allocated based mainly on scientific excellence. Funding for applied research involves a multitude of considerations. These include economic viability, innovativeness, contribution to the public welfare, employment and sector enhancement, market comparative advantages, effective (scarce) natural resource utilization, and more. ICT supported evaluation is indispensable in incorporating and integrating these considerations.
4. Managing implementation of the approved research proposals in the various venues includes:
 - Final approval of the chosen proposals and funding them
 - Follow-up during the research duration including decision-making, changes and termination mid study if and when necessary – the procedure involves professional monitoring of the written scientific and fiscal annual reports for each approved proposal till its completion, in addition to ongoing verbal updating and frontal review by professional panels and periodic scientific inspections at the research sites;
 - Follow-up of the dissemination of the research results to all relevant "clients" and their implementation

The economic evaluation routine as an ongoing process has improved over time as the calculations and collaboration with "pencil and paper" calculators were substituted by now standard ICT tools and ICT supported procedures. The main management improvements involved the ease of economic evaluation iterations, interaction between proposal initiators, collaborating researchers, potential research results users, and funding managers. Since funding allocation is decided competitively ICT enabled, evaluation-transparency was and is essential. The unique contribution of ICT in this case over the traditional pencil and paper reporting is focused on real-time follow-up, ongoing iteration of economic alternatives, their consideration, real-time feedback to "research in process", research elsewhere, and eventually planning implementation of results.

5. Managing the reporting of interim and final research results – verbally and formally by dissemination of the results to end users – farmers via the extension service, researchers, others, and publication. This process and its transparency is a major beneficiary of ICT facilities.

In all these five stages ICT plays a critical role by enabling the system to involve large numbers of individuals in their various diverse capacities and exposing them to large databases. In turn, ICT facilitates dissemination of the research results to the various potential beneficiaries. In this case they include agricultural producers, extension, follow-up research, agricultural services and international collaborators. This collaboration has become a mainstay of international collaboration as well – mainly sharing initiatives, information, joint research activities, and their results.

King and Scholar (1997) compare various public funding agricultural research mechanisms in the United States, the United Kingdom, Australia, Germany, and the Netherlands with the procedures in Israel. They commented on the efficiency and benefits of the Israeli procedure, which combines competitive evaluation and acceptance of research proposals with and without institutional funding of the national scientific infrastructure. They lauded the achievements of the multiple public and private funding sources: “Israel provides an excellent example of cost effective research”, and “Israel shows quite dramatically that a system can intertwine an intramural research with competitive grant project funding to maximize research productivity and provide direction towards pre-determined national objectives” and the above detailed interaction with farmers and regional research outline ICT’s dominant position in enabling effective decision-making based on public priorities, monitoring their implementation, and disseminating the results.

RESEARCH MANAGEMENT CHANGES RESULTING FROM ICT ADOPTION

The following lists the changes and/or improvements enabled by ICT adoption:

- Online and real-time addressing of large audiences efficiently via the Chief Scientist’s Portal and individual e-mail contacts. Both in turn facilitate online accessing of relevant information and individual contacts as and when required;
- Computerized handling of the research proposals enable improved and efficient decision-making. The proposals can be efficiently categorized according to decision-making criteria. These include crop/subject differentiation, spatial orientation, innovation category, scientific discipline, required research duration till implementation, scientific and agricultural innovativeness, economic contribution, and more. In this case avoidance of duplication, repetition, and details of international study results availability are a prime benefit in efficient funding, human capital allocation, and their management.

- Innovative dissemination technologies shorten end-user result accessing lead times; enable provision of more detailed and varied information, feedback, and interpersonal interactions. These in turn provide the Chief Scientist with an enhanced ability to monitor and manage research in process and interact with the researchers.
- An unsuccessful research project is not necessarily a failure. The knowledge gleaned from the research might be useful in its own right and as a significant input to other research activities. The most prevalent case is avoiding repetition of mistakes. In terms of efficiently managing public funds ICT supported “organizational memory” effectively ensures avoiding allocation of “soft money” (funding of research programs) just for supporting “hard money” (existing scientific infrastructure and personnel). Making “unsuccessful results from the past” common knowledge saves a lot of time and resources. Respectfully saving all research results involves a human satisfaction factor critical to scientific productivity. The existing ICT supported overview of all research activity contributes to this aspect.
- Allocation of human capital as a criterion for allocating funding for research is at best a delicate issue. Discrete anecdotal evidence suggests the validity of this observation. In practice ICT enables the Chief Scientist to anticipate human capital requirements, among others, during the ongoing stages of monitored studies. With these details necessary human capital support can be provided. Proposal evaluation supported by ICT tools can indicate the need of a multidisciplinary approach in terms of necessary additional input of human capital. Lack of sufficient human capital might evolve into becoming a critical success factor. Formal, published research of such ICT contribution to identify such occurrences will provide funding decision-makers with tools to initiate remedial measures.
- ICT potentially flattens various hierarchies – among them information accessing. The various evaluation procedures described above employs hundreds of scientists and other agricultural professionals. These ICT supported procedures provide access to all information available and relevant to proposal evaluation and monitoring. This has yet to be perfected, as detailed below, with facilities for providing access to all involved and concerned.

DETAILED EXISTING AND BEING DEVELOPED ICT

It is impossible to imagine managing the Israeli public research funding system without the extensive and advanced ICT described above. The specific ICT include:

- An Internet site which enables interactive communication with a large number of varied users. The site provides proposal and report forms with instructions how to use them, general background material describing Israeli agricultural state of the art, which includes “crop pages” with specific data and economical evaluation for many of Israel’s important crops. In addition

the site provides calls for research proposals, addresses of researchers, institutions, Agricultural organizations, sources of information, and lists of relevant contacts.

- A Decision Support System (DSS) for managing and supervising research implementation. In addition to continual data input the DSS itself is constantly upgraded as needed, insuring compatibility with the specifics of the various research projects. This facilitates the ongoing management decision processes, management of the allocated funds, and supervision of subject matter content of the research in progress.
- A Knowledge Base Management System (KBS), which enables decision-makers' ongoing access to information while evaluating research proposals, monitoring the implementation, and assessing the benefits from the research results.
- An advanced review and documentation center.
- An elaborate formal economic evaluation framework – that includes multiple interactive economic evaluations and comparison of research alternatives and result.

From a management point of view various operative ICT, although planned, have yet to be incorporated. One example is a paperless environment with electronic forms. This framework will serve the whole decision-making process before proposal selection and later while monitoring the approved projects. The main constraints in realizing this plan are various legal aspects involving commitments by the researchers, their respective institutes/organizations and authorities. Solving these will enable realizing this planned enhanced system efficiency.

ICT'S CONTRIBUTION TO INTERACTION WITH RESEARCH-RESULTS END USERS

It is almost impossible to exaggerate the importance of ICT in enabling interaction with the end users, beneficiaries, the public at large, and international collaborators. As outlined above farmer participation in deciding and funding the research priorities enables a "bottom-up" contribution to a traditional "top-down" public funding allocation framework. Participants include the research personnel (which in some cases can be the farmers or other beneficiaries), the Institutes funding or contracting the studies, those involved in the funding allocation process, end users, and the public at large. ICT facilitates real-time access to information in addition to:

- The rapid rate of knowledge and innovation transmission – with the Chief Scientist's site and e-mail leading the way;
- ICT enabled public accessibility to available information – with identified demands from publicly funded research that were larger and more varied than formerly assumed. Experience indicates that previously unassociated individuals joined the Chief Scientist's clientele following publications on the

Chief Scientist's site. This assessment is supported by the constant increase of sessions and downloading of files from the Chief Scientists internet site within the Ministry of Agriculture's set of services.

- Real-time response to comments, questions, and suggestions from the public in general in addition to specifically involved research participants. This enables their incorporation in Chief Scientist priority decisions and inclusion in ongoing interim benefits.

To complete the picture a short description of a regional R&D entity follows.

ICT-SUPPORTED R&D IN THE ARAVA REGIONAL RESEARCH PROGRAM

The Arava is an area in the south of Israel, characterized by desert conditions, hot climate with a limited supply of water suitable for agriculture. The Arava Regional R&D ICT Center was initiated in the early 1980s and formally integrated in the regional R&D center in 1992. It has initiated over the years, and operates a large number of various ICT supported services. The center maintains the regional ICT infrastructure, provides technical services, supports tens of research projects held in trial plots, dedicated structures, greenhouses, and other environments and manages the input of data regarding irrigation, crops, pests, product quality, and more. The center employs three professionals – two technicians and a director who provide the ICT services to the Arava regional council. The center's main activities involve technical support, data management, and information dissemination. A major effort is spent on early detection of ICT development flaws and system constraints in view of costly remedial measures and scarce human capital.

The research management methodology and research decisions follow the national framework of decision-making described by Loebenstein and Putievsky (2007). To this framework are attached the regional elements considered and added on by the regional farmer's research committees (Gelb and Kislev, 1982). The regional research management is totally dependant on ICT supported tools as is the region's interaction with the national research programs. The bidirectional flow of data, information, research results, and interim feedback to farmers, extension, scientists, and service providers have made the region an agricultural success story.

The regional agricultural ICT infrastructure includes an extensive communication network and services, data, information and knowledge bases, computer supported control systems – e.g. greenhouse environmental controllers, irrigation, water recycling, fertilization management and fish pond management, data loggers, agrometeorology facilities, and various computers and computer embedded devices.

Information management is the center's major activity. It involves collection of a wide variety of data types from a wide range of sources, verifying the data and processing it into reports. The information is then further processed for

support of regional and individual operative decisions, input to knowledge bases and backed up for future use. Regional and national users and beneficiaries of the data include farmers, extension, scientists, and service providers. The Information and Communication Technologies operated by the center and farmers involved are the most developed and innovative systems and equipment available on the market. Communication interactivity and information dissemination is both passive and active. This includes routine information, e.g. weather and pest reports, current market data, extension recommendations, and in turn research results and regional organizational information.

The extensive agricultural research activities in the Arava are managed by the Arava regional R&D center in collaboration with the regional ICT center. Both are publicly funded – mainly by the national Agricultural Research infrastructure and the region. Research results are evaluated by both entities mainly with the help of, and dependant on, ICT.

PROBLEMS IN ADOPTING ICT FOR MANAGEMENT OF PUBLICLY FUNDED RESEARCH IN AGRICULTURE.

Four categories of problems in effectively adopting ICT for management of publicly funded research became urgent issues. They have yet to be routinely integrated in research funding management methodology.

The first was a major problem in collaboration with unstructured frameworks such as regional or random contributions from farmer organizations. The problems were a result of the incompatibility of various organizational cultures and structures. Integrating scrutinized public funding procedures with farmer requests unhindered by formal and structured decision-making frameworks occasionally made the whole research funding process cumbersome, ineffective, and counterproductive. ICT went a long way to smooth out such problems by facilitating collaboration – sometimes under intense short- term problem-solving necessities.

The second was ICT illiteracy – within the various aspects of digital divides. They are not limited to “have – have not” and how to use a “computer/internet/computer supported device” considerations. They include how to use ICT when accessible, how to integrate ICT in the production chain, how to avoid information overload, “computer made” mistakes, farmer “age” constraints, unnecessary “market push” hardware/software updates, and more.

The third was the inflexibility of government formalities imposed on Ministry funding and activities. A national Information Society (IS) initiative adapting government procedures to ICT supported programs is now in place. In the long run these constraints should be insignificant.

The fourth was adherence to international procedures, regulations and collaboration agreements – all facilitated to a great extent by adoption of ICT supported procedures.

THE ISRAELI CHIEF SCIENTIST RESEARCH MANAGEMENT MODEL

As outlined above the following benefits are the result of the ICT component of the Israeli case study management-model and details:

- The overall ICT supported centralized public funding management enables consolidation of team efforts under the Chief Scientist's umbrella.
- The Chief Scientist ICT facilities enable a follow-up of the allocation match-up of scarce human capital with Ministry priorities and subsequently identification of future human capital needs via the details of the public call for proposals.
- The various ICT supported aspects of this model enable a global approach to need priorities, resources, and goal attainment.
- The ICT supported management model enables integrating research efforts, research result dissemination, end-user feedback with overall public welfare.
- The Chief Scientist monitored research structure hierarchy is "flattened" by ICT resulting in more efficient research results implementation.
- ICT enables the Chief Scientist to maintain an impartial mediating function between research beneficiaries as a source of research funding and public interest funding.
- The Chief Scientist overview can identify ICT subject matter research needs and priorities – an issue with major potential cost overruns and missed opportunities. In this case the follow-up and monitoring of research in progress provides real-time indication of budget compliance and overruns. Feedback provides indication of missed opportunities within the budgeted programs.
- The Chief Scientist model is a focal point for identifying ICT spillover opportunities via the economic analysis of proposals and the monitoring of the approved proposals.

ICT CONTRIBUTION TO CONTACTS WITH RESEARCH MANAGERS ABROAD

Within Israel all the above is Hebrew-specific with the Chief Scientist's site being accessible in Hebrew worldwide. This in turn however, is a constraint for international cooperation and collaboration. This impediment is characteristic of all independent national governmental research in Israel and other non-English reporting countries. Use of mainly English is however standard for binational, multinational, and internationally funded research programs included in the Israeli agricultural research programs. With this in mind ICT can make a major contribution to making the Chief Scientist's site at least bilingual. This can go a long way to enhance international collaboration with Israel's agricultural research. In addition "Automatic" translations are getting better by the day.

MAIN ICT ATTRIBUTES — CONCLUDING REMARKS

Following are the main suggested ICT attributes for managing publicly funded agricultural research:

- Accurate monitoring of fund allocation
- Shorter lead times for implementing research
- Improved evaluation of study proposals
- In-service communication efficiency
- Improved collaboration, research integration, and human interaction with regional-based research
- Improved collaboration between the various sources of “public funds”

REFERENCES

- Alston, J., Norton, G., and Pardey, P. 1995. *Science Under Scarcity: Principles and Practice for Agricultural Research Evaluation and Priority Setting*. Cornell University Press, Ithaca, NY.
- Alston, J., Christian, J., Jason, E., and Pardey, P. 1999. *Paying for Agricultural Productivity*. Johns Hopkins University Press, Baltimore, MD.
- Boyce, J., and Evenson, R. 1975. Agricultural Research and Extension Programs. Agricultural Development Council, New York. pp. 18, 101.
- Evenson, R., and Kislev, Y. 1975. *Agricultural Research and Productivity*. Economic Growth Center, Yale University, New Haven, CT. pp. 15–31.
- Eyal, S. 1996. “Feasibility of Investment in Agricultural R&D” M.Sc. Thesis. Technion (in Hebrew).
- Gelb, E., and Parker, C. 2005. Is ICT Adoption still an Issue? E-Proceedings EFITA Conf. Villa Real, Portugal. <http://www.efita.net>
- Gelb, E., Getz, D., and Oberman, G. 2003. ICT Spillovers in Rural Areas (An ICT Adoption review). E-Proceedings. EFITA Conference, Debrecen, Hungary. <http://www.efita.net>.
- Gelb, E., and Kislev, Y. 1982. Farmers’ financing of agricultural research in Israel. *Research Policy*, 11:321–328.
- King, J., and Scholar, T. 1997. Funding Public Research: An Analysis of International Agricultural and US Federal Agency Research Funding Mechanisms. USDA, report. pp. 34–36.
- Griliches, Z. 1958. Research costs and social returns: Hybrid corn and related innovations. *Journal of Political Economy*. 66:419–331.
- Levanon, D., Levkovitch, G., and Rophe, T. 2005. Contribution of the Agricultural R&D in Israel. Ministry of Agriculture Rural Development, Israel. www.science.moag.gov.il/frametruma.html
- Loebenstein, G., and Putievsky, E. 2007. Agricultural Research in Israel. In: Loebenstein G. and Thottappilly G. (eds.), *Agricultural Research Management*. Springer, Dordrecht, The Netherlands. (Forthcoming)
- Maoz, A. 2006. Information and Communication Technologies (ICT) Adoption as a Tool for Agricultural Research Coordination and Information Dissemination (Genomics ERA-NETs case study review) in ICT in Agriculture: Perspectives of Technological Innovation. Forthcoming at: departments.agri.huji.ac.il/economics/gelb-main.html
- Ruttan, V. 1982. *Agricultural Research Policy*. University of Minnesota Press, pp. 1–18.
- Zimmerman, E. 2006. The Need for a Standardized Current Research Information System (CRIS): A “Call to Arms”. Proceedings “Gaining Insight from Research Information”. <http://www.uni-kassel.de/CRIS2002/files/pdf/Zimmerman.pdf>.

CHAPTER 9

HARNESS OF R&D FOR THE BENEFIT OF A PRACTICAL-ORIENTED ORGANIZATION

I. SPHARIM

Formerly, economic advisor and head of the economic division of the Agricultural Research Organization, Bet Dagan, Israel; presently economic advisor to the Jerusalem Outline Program 2000

INTRODUCTION

In many countries, including the United States and Israel, governments provide agricultural research services to many small farm holders. The governments of these countries operate their own research institutes and laboratories where management tries to guide scientists in conducting research and development (R&D) for the benefit of the producers, consumers, and the society as a whole. Traditionally, the benefit of agricultural research was evaluated by measuring it *ex post* (Grilliches, 1960.) This evaluation was of little help for decision-making process of agricultural R&D management. I thought that the management of the private sector might do it differently and maybe better. Agricultural Research laboratories are involved in different types of R&D. Basic as well as applied, improved production processes as well as new or improved products. The agricultural R&D portfolio includes disciplines such agricultural engineering and food technology as well as plant physiology and genetics, and projects that will reach commercial application in a short or a long time.

The task of managing such a diversified portfolio justifies efforts to learn from the experience of other organizations outside of agriculture. Organizations that parallel in dimensions to the R&D management problems that the agricultural institutes encounter. For this a survey was conducted in 1980 of about 40 organizations, including 30 businesses (mainly manufacturing firms), 10 governmental, of which 5 were agricultural and 5 nonagricultural organizations. The following questions were asked: "How are scientists led to work for the benefit of your organization?" After evaluating the results the following two conclusions were reached:

1. There are R&D management problems, which are common to all organizations studied.

2. Wide differences exist in the way the various organization deals with these problems.

The information gathered by interviewing the vice president for R&D or the head of the laboratory of about 40 organizations, was analyzed in the following way:

1. Identification of generic problems.
2. The answers given by the organizations to each one of the above-mentioned problems.
3. Typology of organizations, and search for the link between the type and the answers given by it, to the above- mentioned problems.

Generic R&D management problems

1. What kind of research to pursue
2. How to help information flow smoothly between the laboratories and other organs of the organizations
3. How to evaluate, select, and control research projects
4. How to determine the best incentive system for scientists to make them work for the benefit of the organization
5. How to manage R&D that is aimed at new products
6. How best to transfer R&D results to production
7. How to have an R&D policy in a changing environment

How to have an R&D policy in a changing environment

What kind of research to pursue

- To this the survey supplied the following answers:
- To react *ex post* (after what happened)
- To aim a shoot gun (i.e. to variety of scenarios)
- To aim a sniper's gun (i.e. to one scenario)
- To buy information in order to reduce uncertainty about the future
- Strategic planning

Not every organization can afford to choose among all these options. For example: to aim a shoot gun, one needs a lot of resources, and is advisable for an organization that has only a short reaction time to react *ex post*. Strategic planning is based on the idea that the future is not a scenario on which we have no influence, but have room to maneuver and plan. Some organizations chose not to have long range planning; while others are using different planning methods.

Scientific activity is basically an activity of processing information. Scientists get information from various channels, add value to this information and pass this new information on to someone else, either to a scientist in the same organization or elsewhere. If there are many research teams they form a research network. Many individual scientific activities interact throughout information channels, and the network of information channels form "The R&D Process".

The R&D process can be divided in many ways. One useful way of dividing the R&D process leading to practical application involves five phases, as described by Evenson and Wright (1980) and Evenson and Kislev (1975).

1. Scientific-disciplinary research
2. Applied or mission-disciplinary research
3. Mission-oriented invention or technology discovery
4. Development
5. Commercialization

The scientific-disciplinary phase includes R&D activities like: exploratory research, the study of nature’s mechanisms, or the development of new techniques and new tests. The mission-disciplinary research includes all the R&D activities, which are relevant to a group of products or processes. The mission-oriented invention is the beginning of concentrated R&D efforts towards a well-defined practical mission, and the development phase is that phase which leads to the embodiment of the invention in a new technology.

If the R&D process is a flow of information from one R&D activity to others, the pattern of the information channels of this flow may serve as a useful clue for the identification of the appropriate R&D phase. These patterns are described in Figures 1 and 2:

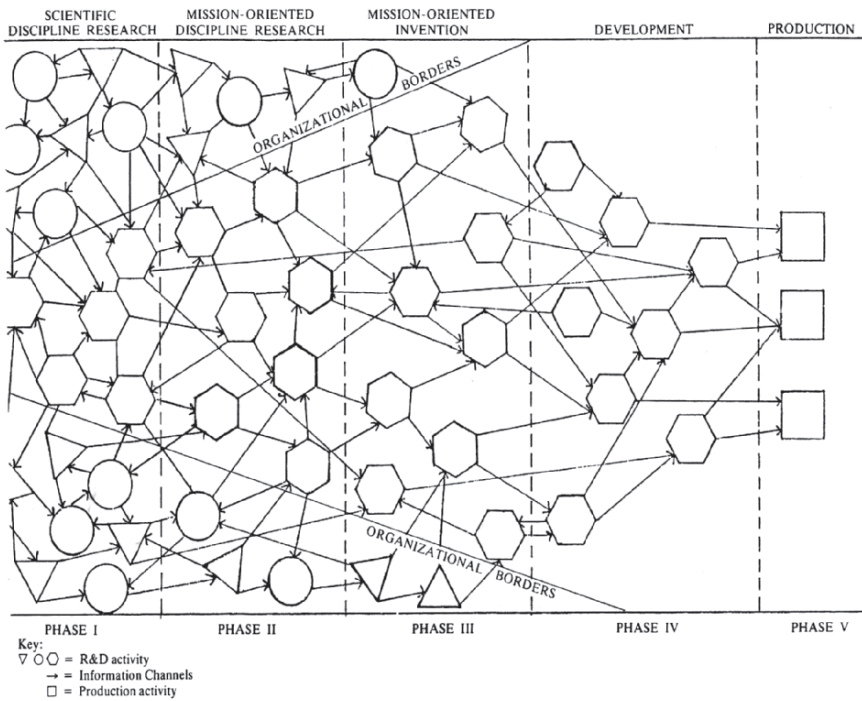

Figure 1. Interaction within the R & D process.

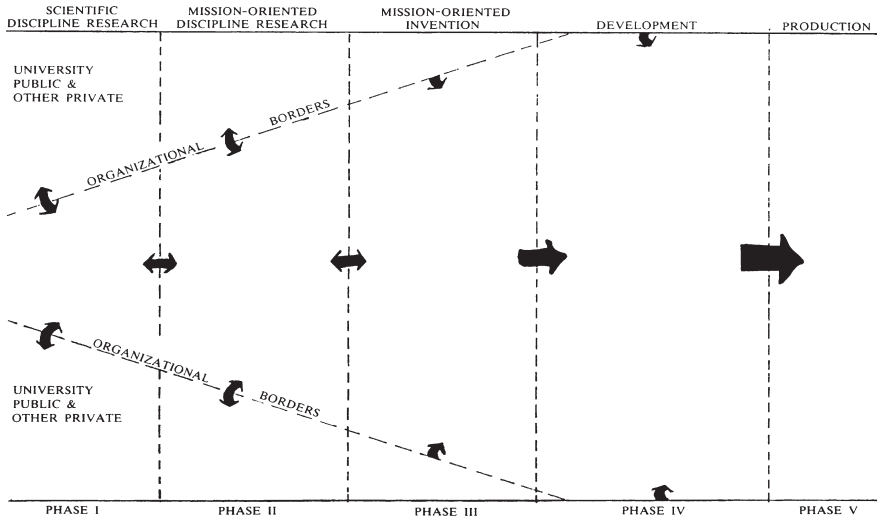

Figure 2. Information flow at different R&D phases.

1. Information channels
2. Information junctions
3. Sources of information
4. Organizational borders

An applied oriented research organization chooses a set of particular R&D activities for its laboratory, leaving the rest of the R&D process outside its organizational borders.

In the first two phases, most sources of information are from R&D activities and information channels frequently cut across organizational borders. In the second two phases, more and more information is obtained from non-scientific activities, such as production and marketing, and most of the information channels do not cross organizational borders, especially not in an outwards direction.

The slice of the R&D process which an organization cuts for itself

If an organization like General Foods or the Israeli Ministry of Agriculture wants to conduct R&D, it will cut a slice of the whole R&D process, a slice that will fit in with its R&D strategy. A slice of the R&D process may consist of many R&D activities. This slice of the R&D process has two dimensions:

1. The organization's products and process areas
2. The range of R&D phases

Different organizations cut different slices. For example, Gerber cuts a slice that mainly involves the development phase of food products research; it is not large enough to support more phases. General Foods cuts deeper and includes, in their laboratories mission-oriented inventions and some mission-disciplinary

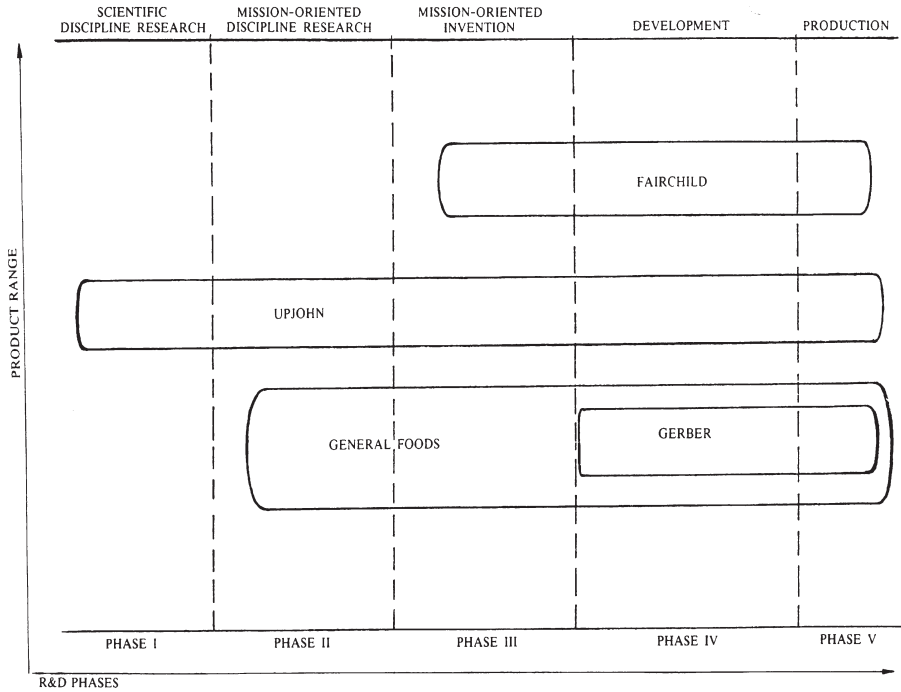

Figure 3. Slices of the R&D process.

research, which is a step closer to basic research. General Foods does not cut into more basic research because it gets this type of research from US Department of Agriculture. Upjohn cuts all the way through pharmaceutical R&D, i.e. through all the R&D phases, including some scientific-disciplinary research. This is necessary, if Upjohn wants to be first with some therapeutic agents that do not exist yet, and Upjohn is in the fortunate position to afford it.

Typology of organizations

From the information acquired on about 40 different organizations, a typology of organizations was crystallized and a link between organizational types and the way the organization handles its R&D was established. The result enables us to say, "tell me what type of an organization you are and I will know how you handle your R&D". This typology might be useful to a manager who wishes to borrow R&D management tools from other organizations. Following is the description of the typology and a few examples of organizational types will be presented. Finally some examples of R&D management tools that were borrowed by the Israeli Agricultural Research Organization will be mentioned.

Definition of organizational types

The following five criteria were used to define a type:

1. The number of groups of products that the organization produces: One or many
2. The kind of products that are produced: Intermediate products, or products for final consumer
3. The market situation: The organization may have a large share of the market to dominate it, or it may face strong competition. The market may be comprised of many competing buyers or only several large ones
4. The availability of relevant R&D, which can be acquired from external sources (government, parent organization, or universities); this dimension is measured by “availability of external R&D” at one extreme and “unavailability” at the other extreme
5. The efforts dedicated to diversification, i.e. change of organizational product mix: Low-, medium-, or high-diversification efforts

Several types of organization

A few types of organizations will be described according to:

- Organizational type
- Description of the organization and its strategy
- The matching (appropriate) R&D strategy and tactics

TYPE A

One group of products for personal consumption, market domination, availability of external R&D, low diversification efforts.

Description of the organization and its strategy:

1. One group of products, which are either good substitutes or complementary from either a production or marketing point of view.
2. The products are for final consumption in a market consisting of many small buyers (households). The company constitutes the biggest supplier to this market, capturing about 70% of it; competition consists with several smaller companies.
3. The company focuses on increasing productivity, as well as keeping its market share intact. The company makes only a limited effort in gaining new markets by changing the products mix.
4. The organization can turn to external sources for obtaining the nonproprietary, more basic type of research. Its R&D is usually concentrated on the development phase. Government regulation may affect the company and this becomes a major concern and an incentive for counter-strategy at the highest company level.

R&D strategy

1. The R&D effort of this type of organization is relatively limited. It has one central company laboratory.
2. Most of the R&D will be concentrated on process improvement research. If an effort is made in the field of “an improved product”, it will be the type for “a better second generation of our good old products”.
3. The company will exercise a defensive technological competition policy and try to counter existing market threats and will not strive to be first in the market with a new product. The company might use acquisition as well as in-house R&D to defend its product’s market share.
4. The main R&D effort will be concentrated on the development phase. Some mission-oriented invention type of research will be done in order to close knowledge gaps or to start a new process. The typical time span of R&D projects for this type of organization will be between 1 and 3 years.

R&D tactics

1. The company has one central laboratory to conduct all of its R&D, and is working on various projects. R&D projects will comprise a well-defined organizational entity with responsibility for financing and attaining technical objectives.
2. Scientists of the organization work towards well-defined objectives. They and their superiors seek marketing and financial results of their efforts.
3. In this type of organization, the R&D is market or production oriented. The production and marketing management dominates the evaluation and selection process and has a major say regarding new ideas for R&D projects. In the case of new or improved processes, the production management will develop in collaboration with the laboratory the technical objectives. The scientists will propose R&D projects to meet these objectives. Production management and the laboratory staff will evaluate the expected benefits of the projects and select the best. The main risk is the technical one, and in this type of organization that concentrates on the development phase, it is limited. The production people may also conduct the *ex post* evaluation more easily by measuring changes in productivity. In the case of improved products, marketing people will take the lead, and because the market consists of many different buyers, the problems of assessing the size of the market and market share are greater, and there is considerable marketing risk involved in addition to the technical risk. In most of the organizations, marketing production and financial management are formally involved in the *ex ante* R&D evaluation and selection process. The marketing and financial people may be the people who do the *ex post* analysis of improved product R&D by measuring the change in market share and income.

4. In this type of organization, the flow of information to and from the marketing and production management and the laboratory is essential for good results. There are many ways to accomplish this, one of which is the physical location of the laboratory close to company headquarters or to the production plant. Another way is a careful recording of the decision-making process. One company uses quarterly review seminars, whereby the production and marketing people review the R&D projects and express their needs. In another company the cafeteria was built between the laboratory and the company headquarters to enable informal exchange of information and views.

New product strategy

This type of organization has, as its main goal, the production and marketing of a group of products. A good deal of the organizational resources is tied into the production of these products, including most of the company's expertise. If the company has already captured most of the market, it has no interest in developing an improved product, which will compete with its existing ones, and thus cause a waste of the company's resources. Therefore the company is not that eager to be first with improved products in the market. Usually, the initiative for product improvement will come from their marketing people who monitor market threats. The laboratory management will translate these market threats into technical objectives that, if some scientist finds some promising R&D approaches, will eventually become R&D projects. In the course of the R&D process, these product-marketing tests will be used to make the decision about commercialization. Some companies develop and elaborate monitoring systems using "line-test" methods in order to monitor their marketing strength in each product and to assess market threats

Transfer to production process

The laboratory works closely with the production plant, but still there are differences of language and concepts. The production work is done according to a manual, but there is not yet a manual for the new or improved production processes developed by the laboratory. In most cases, some overlapping between development and commercialization and between commercialization and production solves the problem.

Forming R&D policy in changing environment

In this type of organization the time spans between the initiation of the research project and commercial application are relatively short. This planning horizon is manageable and R&D planning fits into the usual planning of companies operation.

TYPE B

Many groups of products for final consumption, competitive market, availability of external R&D, medium diversification effort.

Description of the organization and strategy

1. The company produces many groups of different products mainly for final consumption. Much of the company resources are involved in the production process.
2. The company is a major supplier to a market of many small buyers (households). The company faces competition only from a few other big suppliers in this market, as well as many small ones, each having its own market niche.
3. The company works on increasing its productivity as well as on increasing its market share, including searching for entirely new businesses.
4. Governmental research supports many of the company's product lines, especially in the early R&D phases. Government regulations pose a real obstacle with regard to the desire to obtain true diversification. Forecasting and countering these regulations must be taken into account in the companies' strategic planning.

R&D strategy

1. The company has a fairly large in-house R&D set up.
2. About half of its R&D is process-improving-oriented. The other half is oriented toward product improvement as well as development of new products, including new products that will form the basis for entirely new businesses.
3. The organization assumes technological leadership and its laboratory will strive to be first in the market with new or improved products to capture new markets or to increase market share.
4. Most of the company's R&D will be concentrated on mission-disciplinary research, mission-oriented invention, and development/commercialization. The time span of the company's R&D cycle will be medium, i.e. between 7 and 10 years. Some of the organization's products have a very long product life, others not so long.

R&D tactics

1. The company's R&D is organized into a combination of central and divisional laboratories. Most of the divisional R&D will be of the developmental type. Most of the central laboratory research will be mission-disciplinary and mission-oriented invention types.
2. The evaluation and selection process in the division will make greater use of production marketing and financial criteria. Evaluation at the central

laboratory will use more scientific criteria as well as try to examine the scope of the problem, e.g. whether or not the problem is generic to a lot of the company's activities. The divisional labs contract the research at the central laboratory, and have therefore a major influence on the selection of R&D projects in the central laboratory. Most of these organizations use very general evaluation criteria in the early R&D phases, e.g. "We will not start a mission-oriented invention phase if we know that the estimated market of the candidate product is smaller than \$50 million a year, but we will start smaller projects if the production process will use existing production lines". Later on, in the progress of the research through the respective R&D phases, they use more detailed evaluations, including standard financial analysis of the candidate's contribution to the company's net income and its effect on the company's financial resources.

3. Information for making decisions

- For this type of company, the problem of translating consumer or production needs to scientific objectives is critical. This type of organization is not a "technology push" but "market or production pull". The expected change in the product or process is considerable, and may be achieved by many different R&D approaches that production and marketing people do not, at times, have the capability to evaluate. That is the reason why companies of this type devote a lot of effort to the task of translating user needs to the scientific language of technical objectives, so that the scientists will be able to choose the right approach to achieve users' needs.
- The markets information to support the new or improved product effort is not easy to obtain, especially in the case of consumer products sold to millions of households. This type of company invests a great amount of effort to obtain the necessary information but marketing remains the major risk of the company's R&D. The other risks are governmental regulations, which are applied more strictly to consumer goods, while the technical risks come last.
- Many organizations of this type are aware of the problem of channeling information needed for the R&D activity and the R&D decision-making process. One solution, common to organizations of this size, is the use of divisional laboratories, thus shortening the channels between the development phases and the marketing and production units. On the other hand, this organizational set-up creates a problem of channeling information between the divisional and the central laboratory, or to other organizational generic mission-disciplinary research efforts. Companies found different solutions to this problem: Some work on identifying generic problems common to many of the companies divisions. Some use the contract system to deliver the message by having the divisional laboratories contract research at the central laboratories. Others attempt a series of reorganizations that involve different way of centralization and decentralization.
- The company's mission-disciplinary research cannot be evaluated *ex ante* by expected benefit because this information is not available at that phase. This type of organization will use, for *ex ante* evaluation, criteria such as promising research areas and interproducts generic R&D problems.

4. R&D in a changing environment.

The time span of R&D in these types of companies is long enough to make the laboratory management worry about, or take advantage of, future changes in the market situation. Most companies of this type have strategic planning, which includes as a major input the forecast of social trends. The strategic planning includes the assessment of future market potentials, in addition to assessing its competitive edge. In general, they might have a hierarchy of strategic planning levels: general social, company's product area, technological forecast of the company's competitors, company strengths and weaknesses, company strategy, company R&D strategy, laboratories R&D program. This will be done at various management levels; the first two may be obtained from outside sources.

5. The main effort of these companies is invested in production.

Much labor and capital is tied into the production of the existing products and restraining rapid change of product mix. In addition, developing new products involves special types of risks, which ordinary production and marketing management are not used to take. Some organizations of this type have "new product divisions", that have no existing production lines, and whose main role is to find ideas for new products and to promote them through all the R&D phases to production and through the organization's production and marketing organs. There are two kinds of new products, those replacing existing ones, and new products that aim at new market segments or entirely new business. The second kind which will not have the backup by the existing production or marketing division, will be the natural clients of this new product division, but the product replacing existing ones pose a threat of cannibalization to the existing production lines and thus need the new product division to defend them from the rest of the company.

6. Transfer of R&D results.

The methods used to transfer laboratory research results to production in this organization are similar to those used by smaller organizations. The problem that is unique to these types of organizations is how to transfer research results from the central to the divisional laboratories. Sometimes the existing divisions do not accept result. The companies solve these problems differently, some having a kind of referee system of the central laboratory in the divisional laboratory, others using a kind of seminar system.

TYPE C

Many product groups, most of them intermediate products; the firm has considerable market domination. External R&D unavailable, high diversification effort.

Organization and general strategy

1. The company produces different groups of products, mainly intermediate products. The main interest of the company is its market share (in contrast with productivity).

2. The company has to market its products in a multibuyers' market composed of many individual small buyers as well as several big ones. (It is relatively rare for intermediate products to be sold to many buyers' markets; one case is agriculture). There are very few large competitors in this market, each specializing in some product which it developed and for which it owns patent rights or other kinds of exclusivity. One can assume that each company dominates the market with its product, which is sufficiently unique to have only few substitutes.
3. The company's "bread and butter" is the marketing of new products, which it developed. The organization is a technological leader in its product areas.
4. There is no considerable outside R&D that can be relied upon.

R&D strategy

1. The company invests markedly in R&D.
2. Most of the R&D is concentrated on developing new or improved products, and not much research is done to improve the production process, perhaps because costs of production are not a major factor in the business.
 - The company would like to be first in the market with a new therapeutic agent, i.e. to assume technological leadership. Most of the company's new product ideas will originate in its laboratory. One can call it "technology push type of organization".
 - Most of the company's R&D will be concentrated in the phases from mission-disciplinary research onward, but some research will be done on scientific-disciplinary phases. The industry is very much regulated and government agencies check the quality of its products, the company's R&D time span from initial ideas to products in the market is long, about 15–20 years.

R&D management tactics at the laboratory level

1. All the R&D is concentrated in a central laboratory. In this type of organization, most of the information for the R&D activity and the R&D decisions-making process does not originate from the production or marketing divisions. The laboratory is big enough to have information delivery problems between the different R&D departments and it needs to develop its own channels to and from the market. Those channels are used at later R&D phases for feedback from the market regarding new research ideas, as well as for testing research results. The organization has to develop information channels to and from other R&D institutions, and this is done by a liberal publication policy as well as collaboration with universities on specific research projects. In this collaboration they do not use contract research but prefer collaboration on the basis of the interests of the individual scientists.
2. The laboratory has flexible evaluation, selection, and control systems for its R&D projects. This system changes with projects in different R&D phases. In the early phases, the evaluation and selection relies mostly on

other scientists and laboratory management. At the more advanced stages toward commercialization, more outside expertise is brought in. Different people will take the lead at the different R&D phases. Before the development phase, financial assessment of the project will be made. This type of organization uses mainly scientists for evaluation proposals at the early R&D phases, but because they want the selected proposals to be oriented as much as possible to the mission of the organization, they assign responsibility in a way that makes the evaluators share the responsibility for the outcome. *Ex post* analysis will be done by evaluating tangible results, like the number of new products in the market for 10-year periods per laboratory department.

3. In this type of organization, a considerable portion of research is dedicated to more basic R&D: scientific-disciplinary and mission-disciplinary research. Having this type of research in their portfolio makes the task of getting scientists to work toward the organizational goal more complicated. The whole, usual arsenal of management tools by which management usually controls the R&D process, i.e. evaluation and selection of R&D proposals, control of R&D projects, incentive system for scientist, etc. suffers from the lack of necessary information for making decisions. The loose connection between the research and the useful results, as well as the length of the time span from research to results, and difficulties of communication between those who work at promoting organizational goals and the specialized scientists aggravate these difficulties. Some organizations of this type think that hiring good scientists in the relevant disciplines and giving them good leadership are the major factors for getting results. The scientist should be encouraged to work on the missions of the organization. This is done by promoting mission-oriented projects which include scientists from different disciplines working on one common mission. Relevant here is the conflict, or one may say the trade-off, between professionalism and mission-mindedness. The first step toward surviving this conflict is to organize the laboratory, if it is big enough, into the matrix system: an organizational system where work is organized in a matrix of disciplines – the rows, and mission – the columns. The matrix system raises the following problems: if the project managers take the lead and have all the responsibility and control over resources, the laboratory might suffer from a lack of professionalism. On the other hand, if the discipline management takes the lead with control over resources and the project leader is merely a coordinator of the various disciplines, the project might suffer from a lack of dedication to the mission. This problem is a generic one to this type of organization, and each one has to find its own specific mix of leadership and disciplinary professionalism. Most of the time the practical solution uses complementary measures, such as a leadership matrix with additional organizational systems that are organized by disciplines and serve as educational organs for the whole laboratory.

4. In this kind of company the major obstacles in the introduction of new products are external to the company. Most of them are regulatory threats or market risks.
5. The introduction of a new product into the commercialization phase must be based on the appropriate production process developed by the organization. In this type of organization the role of the production activity is relatively small, production costs are not major factors, and the organization emphasizes performance above productivity.
6. The planning horizon lies far away, about 15–20 years. The major factor in the company's R&D strategic planning is the technological forecast. The outcome is the identification of promising research areas (technology-wise) from the point of view of the scientific state of the art. The R&D strategic planning is on a different planning level than the organizational strategy and is done by a laboratory staff. The ideal process is when the people who take part in the strategic planning are those who evaluate and select the proposals.
7. Back to the Israeli Agriculture. Applying the typology I developed then, to Israeli agriculture of those days, I find it belonged to the archetype described by the following features:
 - Many groups of products
 - Most of them, for final consumer
 - Considerable market domination in many products
 - Governmental R&D available
 - High diversification efforts
 - Long reaction time

While agricultural in many countries at that time and today, defined themselves as traditional industries, Israeli agriculture, of that time would be defined in today's words as bio-hightec. Agriculture was the first hightec industry in Israel.

Between 1980 and 2006 Israeli Agriculture has changed in many ways and the environment in which Israeli agriculture operates has changed dramatically.

At 1980 most agricultural producers belonged to special social communities, Kibbutz and Moshav. Today these communities have turned out to be more like capitalistic firms.

The country has become crowded, house touches house, town touches town, and agriculture has become the garden of everybody.

The state of Israel, which was formed by two ideologies Zionism and Socialism was changed into Normalism and Tacherism.

Many things have changed and I ask myself, what R&D strategy will fit in to today's agriculture?

I suggest the following:

1. Teaching business and business R&D management to agricultural researchers
2. Strategic planning for agriculture and related industries
3. New product agency

4. Searching for new product groups in the following areas:
 - Public products such as environment
 - Quasi-integration of agriculture upstream, with input industries, down stream with processing and marketing.
 - Exploit synergy with tourist industry in the country
5. Increase work opportunities in the periphery
6. Exploit the opportunities of molecular research, in agriculture

REFERENCES

- Evenson, R.E., and Wright, B.D. 1980. *The Value of Plant Biodiversity for Agriculture*. Johns Hopkins University Press, Baltimore, MD.
- Evenson, R.E., and Kislev, Y. 1975. *Agricultural Research and Productivity*. Economic Growth Center, Yale University, New Haven, CT.
- Grilliches, Z. 1960. Hybrid corn and the economics of innovation. *Science* 132:275–280.

PART 2

CASE STUDIES

CHAPTER 10

CGIAR – THE CONSULTATIVE GROUP ON INTERNATIONAL AGRICULTURAL RESEARCH

E. HARTMANS¹ AND GUN LUNDBORG²

¹Former Director General of IITA, Albertus Magnusstrasse 39, D-47259 Duisburg, Germany, E-mail: ermondh@web.de

²Scientific writer, Via Ceppari 37, I-06064 Panicale (Pg) Italy. E-mail: lundborg@alice.it

HISTORICAL BACKGROUND

The Consultative Group on International Agricultural Research – the CGIAR – was founded in 1971 as a strategic alliance among governments, international and regional organizations and private foundations. Its aim was to encourage a greater research effort in order to increase and improve the quality of the agricultural input in developing countries and thus to raise standards of living of the populations. It was triggered by a series of events, which were mainly the natural consequence after many colonies regained their independence in the 1960s.

As very little reliable information had been available about the effective situation in some colonies until they became independent countries, missions were sent out to examine their social and economic conditions. After having analysed their results, FAO, the Food and Agriculture Organization of the United Nations, and IBRD, the International Bank for Reconstruction and Development, realized that something had to be done, and urgently.

More or less during the same period, both Paul Erlich and W.H.Pawley predicted that **without a dramatic turnabout, hundreds of millions of people would starve to death before the end of the 20th century.**

This unveiling of a far-reaching serious situation aroused the attention of more organizations and led to a number of important initiatives. In 1960, the United Nations expanded its Technical Assistance Program (TAP) by establishing a special Fund for Development, which later was called the UNDP, whereby a large part (about 30%) of its resources were assigned to rural development projects in developing countries. FAO launched its Freedom from Hunger Campaign in 1962, under which relatively small development projects could be financed. Two years later, The United Nations and FAO

jointly established the World Food Programme (WFP) by which surplus commodities in the developed part of the world could be used to provide a balanced daily food ration for the worker and his/her family corresponding to half the salary of the worker, who takes active part in agricultural and infra-structural projects in developing countries. Eventually, during the United Nations World Food Conference in 1974, the International Fund for Agricultural Development (IFAD) came to life with the objective to finance agricultural development projects in the poorest countries under very favourable repayment terms.

Some private organizations had also started activities to alleviate the ever-increasing hunger problem in the emerging world. One of these was the Rockefeller Foundation, which since 1943 had financed an International Agricultural Program in Mexico in order to improve the production capability of two important staple crops: wheat and maize. To that aim, modern research infrastructures had been established, technical staff had been trained by the hundreds, local governmental and private sector organizations had been strengthened and, last but not least, top scientists such as Norman Borlaug were summoned to a wider research program, which took place on the premises of the University of Mexico.

In a short time, Norman Borlaug and his colleagues developed, by natural crossing, short straw **wheat** varieties, which, under good management, had the potential of yielding three times as much as the previous local varieties. In 1963, 95% of the wheat grown in Mexico came from Borlaug's breed and the national wheat production increased sixfold.

This accomplishment became the cornerstone for the subsequent creation of the CGIAR system.

During that period, India, like many other Asian countries, was suffering from serious food shortage. Its Government invited Borlaug to help solving their problem. Three Borlaug wheat varieties were imported, successfully tested *in loco* and consequently grown all over the vast country.

Having carefully evaluated these promising results, the Rockefeller Foundation together with another strong private organization, the Ford Foundation, and in agreement with the Government of the Philippines, decided to jointly give **rice** an attention similar to what wheat so far had gotten. As Asia retains 90% of the world rice production, it was decided in 1965 to locate an entirely new kind of international agricultural research organization at Los Baños in the Philippines. This Institute became known as the International Rice Research Institute (IRRI).

By 1966, breeders at IRRI had added a gene from a dwarf plant of rice to the tall local *indica* variety and could put on the market a very new dwarf rice variety, better known as IR8, which, if properly cultivated, gave very high yields.

The first shot announcing The Green Revolution had been fired as this rice, together with the Borlaug wheat, soon rendered India self-sufficient as far as these two cereals were concerned and with India several more Asian countries.

As a logical consequence of these promising results, and at the insistence of President Lopez Mateos, the two Foundations decided to give the research activities in Mexico a structure similar to the one in Los Baños. The Mexican Institute was named CIMMYT – Centro Internacional de Mejoramiento de Maiz y Trigo (International Maize and Wheat Improvement Center) – and its goal was to further improve **wheat** and **maize**.

But the whole emerging world was in urgent need of more help. The Green Revolution had dramatically shown how agricultural research could transform the prospects of the most stricken nations. Sub-Saharan Africa, for example, in spite of its old agricultural traditions, was a continent with severe food problems. Thus, in 1967, the International Institute of Tropical Agriculture (IITA) became number three of the research Centers. It was located in Nigeria at Ibadan, Africa's biggest traditional town. Its mandate was principally to improve some important tropical and subtropical staples as well as soil fertility and farming systems.

Almost at the same time, Latin America got its Center in Cali, Colombia, Centro Internacional de Agricultura Tropical (CIAT) with an equally rich mandate as IITA had, as its research program covered agriculture as a whole in the humid lowland tropics, including livestock.

In the meantime, the report of the Pearson Commission on International Development (1969) urged that agricultural research be massively strengthened and extended to other areas, such as health, and to other crops.

In 1970, the International Potato Center (CIP) in Lima, Peru, was established under Peruvian law and in 1971 it was admitted as a Center of the CGIAR's . It added one more research station in South America to solve the many disease and pest problems of the popular potato tuber. Its focus has lately been on sweet potato for pig feed.

Although each Center had its own specific ecological, social and economic status, some general rules were established, which were later to be applied to any other new Center, i.e. it should:

- a) Be a non-profit research and training institution;
- b) Dispose of an international staff of scientists to be selected among the best available on the market and independently of their country of origin;
- c) Be governed by a Board of Trustees with a majority of the members to be outstanding citizens of the nations to be served.

At the same time, the Centers should be the spearhead and guiding instruments for the national and regional programs of research and development in the mandated areas. This presupposes that they should be in close contact and constant dialogue with the existing local, regional and national organizations of research and development and adapt their research to fit local technologies and practices as well as economic and human capabilities. In our opinion, after the establishment of the CGIAR, these important concepts were initially not always given sufficient consideration. However, major initiatives have been taken to improve the relationship between the Centers and other research and development organizations.

Gradually, it became clear that the cost of establishing and operating such high-class research institutions and their potential universal impact required a broader organizational, financial and international support system than the Rockefeller and Ford Foundations could afford, handle and control. It was therefore agreed that it had become necessary to create an international body in order to manage, finance and coordinate such a large multifaceted enterprise.

A vital initiative to shift this burden to a wider alliance of organizations and governments was taken by the President of the World Bank, Robert S. McNamara. After a series of meetings in 1969-1970, the three most important international organizations then existing for agricultural development: UNDP (United Nations Development Programme), the World Bank and FAO decided in 1971 to sponsor a joint initiative. The result was the founding of **the Consultative Group on International Agricultural Research - the CGIAR**. Its basic content and nature were designed by McNamara and its primary objective was, with its partners, to seek accelerated increases in food production in the developing world through research programs and training of research scientists and production specialists and thus to improve the livelihood of those in need.

In addition to the three main sponsors, the CGIAR was initially supported by 10 donor countries: Canada, Denmark, France, the Federal Republic of Germany, Japan, the Netherlands, Norway, Sweden, the United Kingdom and the United States of America, and by six more donor organizations, i.e. three foundations: the Ford, the Kellogg and the Rockefeller Foundations, two regional development banks: the African and the Inter-American Development Banks and by the International Development Research Center (IDRC), an autonomous organization based in Canada, as well as by hundreds of partner organizations.

In 1971, the year of founding, the Consultative Group sustained the first five international research centers: IRRI, CIMMYT, IITA, CIAT and CIP with a total financial contribution of 15,000,000.00 US\$.

More Centers followed. Their mandates covered any sort of agricultural and food research and for all of them prevailed five priorities, which can be summarized as follows:

- 1) Sustaining biodiversity for current and future generations;
- 2) Producing more and better food at lower cost through genetic improvements;
- 3) Reducing rural poverty through agricultural diversification and emerging opportunities for high-value commodities and products;
- 4) Poverty alleviation and sustainable management of water, land and forest resources;
- 5) Improving policies and facilitating institutional innovation to support sustainable reduction of poverty and hunger.

In the intervening years, the membership of the Consultative Group reached a total of 47 donor countries, of which 22 came from industrialized countries

and 25 from the emerging world, 4 were private foundations and 13 regional and international organizations, i.e. in all 64 members.

The Group provides the 15 International Research Centers with strategic guidance and financial and technical support and is ultimately the decision-making body of the system, while The World Bank, FAO, UNDP and IFAD, which joined the Group in 1976, remain co-sponsors.

Yet, it should be remembered that the true creators and inspirators of the initiative are the Rockefeller and Ford Foundations.

Of the 15 Centers, one is located in North America: **IFPRI** – International Food Policy Research Institute, Washington, USA, and one in Central America **CIMMYT** – International Maize and Wheat Improvement Center, Mexico City, Mexico, two in South America: **CIAT** – International Center for Tropical Agriculture, Cali, Colombia and **CIP** – International Potato Center, Lima, Peru, one in Europe: **BIOVERSITY International** – former International Plant Genetic Resources Institute, Maccaresse, Rome, Italy, one in the Near East: **ICARDA**, International Center for Agricultural Research in the Dry Areas – Aleppo, Syrian Arab Republic, two in South Asia: **ICRISAT** – International Crops Research Institute for the Semi-Arid Tropics, Patancheru, India and **IWMI**, International Water Management Institute, Battaramulla, Sri Lanka, three in South East Asia: **WorldFish Center**, Penang, Malaysia, **IRRI** – International Rice Research Institute, Los Baños, Philippines and **CIFOR** – Center for International Forestry Research, Bogor, Indonesia. four in Africa: **IITA**, International Institute of Tropical Agriculture, Ibadan, Nigeria, **WARDA** West Africa Rice Development Association-The Africa Rice Center, Bouaké, Ivory Coast, **ILRI** – International Livestock Research Institute, and **ICRAF** – World Agroforestry Centre, both in Nairobi, Kenya.(fig. n 2).

Over the past years more Centers were established, but they were subsequently dissolved and most of their tasks have been incorporated in other Centers. **ILCA** (International Livestock Centre for Africa), Addis Ababa, merged in 1994 with **ILRAD** (International Laboratory for Research on Animal Diseases), Nairobi, Kenya, to become **ILRI** (International Livestock Research Institute). The same year **INIBAP** (International Network for the Improvement of Banana and Plantain), Montpellier, France, became a program of **Bioversity International**, Rome, Italy. **ISNAR** (International Service for National Agricultural Research), The Hague, Netherlands, was dissolved in 2004 and its main programs were taken over by **IFPRI** (International Food Policy Research Institute), Washington, USA.

The 15 Centers form a global system with a global perspective of agricultural research and training, as they cover the major aspects of food crops, livestock, forestry and fishery in the developing countries as well as food policy and institutional training. They are the functional and operational scientific core of the CGIAR System, responsible for planning, developing and implementing a research agenda that is approved and funded by the CGIAR.

The results of their research and training services are unrestrictedly and without charge available to national agricultural research organizations, to

farmers and farmers' organizations and to any other potential user worldwide. Through their annual reports, bulletins and other documents as well as their website www.cgiar.org (the CGIAR can be replaced by the name of a specific Center, if so wanted), they render public dominion the work and breakthroughs that each single Center has accomplished. (See list of Internet addresses).

CONTENT AND NATURE OF THE CGIAR SYSTEM

According to the CGIAR Charter, a loosely connected network of several components forms the CGIAR System. The pillars of the CGIAR System are **the Consultative Group, the Science Council and the Agricultural Research Centers**. These three components are all interdependent and supported by **the Executive Council**. This Council is served by a System Office unit which functions as the **CGIAR Secretariat**. The Secretariat is the principal service unit of the CGIAR System and its focal point for relations with external partners, from legislative decision makers and scientific communities in the public and private sectors, to civil society institutions and the general public. From 1974, the CGIAR Chair has been the Vice President of the Bank's sectorial work on agriculture.

The Secretariat is headed by a Director, selected by the CGIAR Chair after completion of an international search process by a Co-sponsor Committee. After endorsement of the Consultative Group, the selected Director is appointed as a senior staff member of the World Bank, heading the Secretariat, which functions administratively as a department of the World Bank's Vice Presidency for Environmentally and Socially Sustainable Development (ESSD). This procedure shows clearly the influential role that the World Bank plays in the selection and further functioning of these two top officials. As this Director can play a very decisive part as intervener in operational and managerial handlings of the different Centers, it seems to us logical that the Center Directors also should have a voice in his/her election.

The Secretariat plans and implements communication within the CGIAR System and is responsible for organizing and managing all aspects, both substance and logistics, of the CGIAR AGM, ExCo meetings, and of any other meeting by the CGIAR Chair or Director.

On the other hand, when it comes to decision-taking within his or her Center, the Center Director General is practically free to take final action and decision within the provisions of the short and medium term research program approved by the Board of Trustees.

As already mentioned, the **Consultative Group** is presently an association of 64 independent public and private sector members with the World Bank, FAO, IFAD and UNDP as co-sponsors. Its main task is to provide the 15 Centers with strategic guidance and financial support. It is ultimately the decision-making body of the system.

According to the Charter, approved by its members on Oct.28, 2004, the Group is responsible for:

- 1) Setting broad policy for the governance of the CGIAR system;
- 2) Approving research programs and research-related activities of the Centers, including Systemwide and Ecoregional programs and activities and multi-institutional Challenge Programs, that constitute the CGIAR research agenda;
- 3) Endorsing funding for CGIAR Centers to carry out approved programs;
- 4) Providing most of the funds for the CGIAR research agenda;
- 5) Monitoring and reviewing implementation of the research activities and overall programs of CGIAR Centers and, when necessary, proposing corrective action;
- 6) Ratifying or endorsing appointments to key positions in the CGIAR system;
- 7) Establishing *ad hoc* committees, study groups, or task forces to review and report on specific issues within a stated time frame;
- 8) Exercising such other functions that may be appropriate to fulfill the mission and objectives of the CGIAR.

Once a year the Group has its Annual General Meeting (AGM), which as a rule takes place in one of the member countries. It is usually divided into two different segments: a Stakeholder Meeting and a Business Meeting. The Stakeholder Meeting has no decision-making authority. Views expressed at the Stakeholder Meeting are reported to the Business Meeting, where they are taken into account. Members, who have not paid their minimum annual contribution of 500.000,00 US\$ for each of the previous two calendar years toward support of research programs approved by the CGIAR, are only admitted to participate as Member-Observers. Paying members are eligible to participate in the CGIAR decision-making and serve on the Executive Committee.

Participation in the AGM is further open to the CGIAR Chair, the CGIAR Director, the incoming and current Chair of the Center Directors, the Chair of the Boards of Trustees of the Centers (each Center has its own Board of Trustees), the Science Council Chair, the GFAR (Global Forum on Agricultural Research) and the Chair or Chairs of the Partnership Committees.

The likely number of attendants at the one-day-long AGM is obviously too big to allow for discussions in any depth on important issues on the agenda. Such discussions must therefore take place before the meeting by individuals or committees interested and concerned in a specific subject and are subsequently endorsed by the AGM.

There are three groups or councils that play important roles.

The first one is the **CGIAR Co-sponsors Group**, i.e. FAO, UNDP, the World Bank and IFAD. It is a small Group consisting of senior staff nominated by the Co-sponsors. The Group meets periodically with one of its members serving as Chair.

The second one is the **Executive Council (ExCo)** which consists of 21 members: 8 non-rotating members: CGIAR Chair, Co-sponsors hosting a CGIAR System governance unit, the Chairs of CBC (Committee of Board

Chairs of the CGIAR), CDC (Center Directors Committee of the CGIAR), Science Council and GFAR (Global Forum on Agricultural Research) as well as 13 rotating members representing geographic and functional constituencies with each member serving for a period of two years. The ExCo is a subsidiary body of the Consultative Group and acts on behalf of the Group between one AGM and another. It also facilitates Group decision-makings by reviewing major issues and submitting recommendations for consideration. Still more important, it provides synopses of the implementation of Group decisions and reviews the terms of CGIAR Committees. In carrying out these assignments, it conveys specific tasks and responsibilities to the CGIAR Secretariat.

The third one is the **Science Council**, or the Science Advisory Body which started effective operations in January 2004. Before the Science Council came into existence, the Technical Advisory Committee (TAC) provided scientific advice to the CGIAR. The Science Council has six members and a Chair, all identified through an International Search Committee established for that purpose by the CGIAR. The Selection Committee's recommendations are reviewed by the ExCo, which nominates the Chair and members for consideration and confirmation by the CGIAR. The members are elected among eminent scientists in the biological, physical and social sciences with rural development experience.

The advice of the Science Council on program priorities is taken into account by the members of the CGIAR when deciding on allocation of resources.

Their work is done through standing panels in four different functional areas:

- 1) Strategies and priorities;
- 2) Monitoring and evaluation;
- 3) Mobilizing science;
- 4) Impact assessment.

The Science Council Chair conveys to the Co-sponsors' Group, to ExCo and to an appropriate stakeholder audience the findings, advice and judgements of his colleagues on strategic issues, research priorities and the quality of research programs supported by the Group. The work of the Science Council is supported by a Secretariat, headed by an Executive Director. This man or woman is a highly qualified senior scientist, selected through an international search process and appointed as a senior staff member of FAO. The Secretariat Offices are based in FAO headquarters in Rome and the final decision for the Director's selection and appointment is made by FAO.

The Secretariat provides technical and administrative support and is responsible for the execution of activities requested by the Council. Its aim is to have a major impact on the sustainable management of natural resources through seven key elements:

- 1) Developing a cohesive research program based on a small number of CGIAR System priorities;
- 2) Developing and implementing new and improved monitoring and evaluation processes for CGIAR-supported research;

- 3) Strengthening medium-term plans (MTOs) and the related logical frameworks for Centers challenge programs and inter-Center programs in the context of the new System priorities;
- 4) Combining the MTOs with annual reporting of accomplishments for better planning and performance appraisal;
- 5) Contributing to the regional alignment of CGIAR research;
- 6) Estimating the impact of CGIAR-supported research; and
- 7) Helping to mobilize research outside the CGIAR to fight poverty and unsustainable management of natural resources.

Among its several studies on priorities and strategies, during the first year the Science Council completed studies on biosafety, on animal and fish genetic resources, on mapping poverty as well as a preliminary work on food safety and ethics.

The Science Council has developed **new medium-term plan guidelines** in collaboration with the CGIAR Secretariat, stressing the importance of realistic and measurable goals and objectives.

THE CENTERS

The 15 Centers form the operational arm of the System. Each Center is legally constituted as an independent, self-governing institution with its own mandate, its Director General, Board of Trustees, research responsibilities, staff and annual budget. It works under a legal agreement with the host country, which may vary among the Centers and the countries they are situated in.

Anyhow, a few management principles are important and, in fact, crucial at all levels of performance. Management decisions in the Centers, as in most national and international organizations, are greatly influenced by three basic factors:

- 1) Political and tactical behaviour;
- 2) Financial resources and their control;
- 3) Factual and scientific information and know-how.

As some 64 countries and financial and private organizations are potentially decision-making members in the CGIAR, it goes by itself that all these members, with different political and economic status, wish their views to be heard when it comes to programming, development and execution. As their views have to be reconciled, this has over time led to the set-up of the already described large superstructure over and recently also among the Centers.

In October 2004, the Center Directors' Committee (CDC) decided to form a coalition among themselves which they named **Alliance of Centers**. Its office is a unit of the CGIAR System Office. Today, it has 11 System-wide Programs and 6 Ecoregional Programs. The principal aims of the Alliance are to maximize cooperation between the Centers, thus strengthening the goals and objectives of the CGIAR, but also, when needed, to solve cases of conflict between the Centers, that cannot be solved by the Centers themselves.

As the Centers function as independent entities and, as happens, may be in competition with each other as a consequence of the Director General being practically independent and free to take initiatives in order to strengthen the role and functions of his or her Institute, their actions may raise conflicts of interest.

One example is of an economic and financial nature. As the Director General is free to respond positively about requests from new donors to subsidize his or her Center, this may lead to the strengthening of its budget. As said money otherwise might have been allocated also to other Centers, this could start a problem among the Centers.

Another case of possible conflict is when the mandates of the Centers are overlapping each other and no strict lines have been drawn up for their specific competences. Such conflicts have arisen from time to time for cassava, maize, rice and livestock to give a few examples. However, as it is in the interest of the Centers to solve such conflicts themselves, positive examples of cooperation are more common in practise than negative ones. A few examples of full cooperation are IITA's and CIAT's research on cassava and IITA's and ICRISAT's on sorghum.

The Director General of each Center is nominated by its Board of Trustees after a Search Committee, set up by the Board, has completed its task. The proposed candidate is normally selected on the basis of a carefully prepared set of criteria, which can differ from Center to Center and even may differ from the criteria used for the parting Director General, depending on the special needs in that specific moment.

There are a few standard criteria which never change such as that he or she should be a person with internationally recognized leadership, have a thorough knowledge of the region and possibly be familiar with the host country. The Director General should also have ability to collaborate with institutions and authorities in both developed and developing countries. A prerequisite is also his or her capacities to form a strong and enthusiastic team spirit between the staff members, considering the multifaceted and often closed community that he or she has to work and live in.

No procedure and guidelines are given in the system for the election of the Director General. Several issues can be raised in this regard. One is whether the staff should be consulted when it comes to the selection of its Chief Executive. In our opinion, at least one senior officer should be part of the Search Committee. Another is whether the final proposal for approval by the Board of Trustees should be subject to scrutiny by a Committee of senior staff of the Center. Co-responsibility of the staff for the selection and appointment of their new leader should be a prerequisite.

RESPONSIBILITIES OF THE DIRECTOR GENERAL

The Director General has full responsibility for the functioning of the Center within the framework of the decisions of the Board, which in turn reflect the guidelines of the CGIAR.

His or her specific tasks should include:

- 1) Establishing a research and development program with specific short-and medium-term objectives. This should be done together with the concerned scientific staff;
- 2) Creating a climate of harmonious and friendly relationship among the multi-faceted scientific staff and with the administrative and technical support staff, most of whom come from the host country;
- 3) Providing maximum freedom of initiative and action among scientists and supervisory staff at all levels;
- 4) Developing close cooperative relationships with the national and any other relevant organization in the mandated area;
- 5) Making all the necessary efforts to obtain financing for priority programs of the Center;
- 6) Maintaining friendly relationships with relevant high officials of the host country;
- 7) Keeping close contact with the donors of the Center and with officials in the countries of the mandated area.

The function of the Director General can best be compared to that of an executive officer of a private company. Only the Board of Trustees, which meets once or at most twice a year, can amend or change the proposed short-and medium-term program, which has been prepared in full consultation with the senior staff and scientists and vetted by the Science Council before submission to the CGIAR for approval at its annual meeting.

Sometimes a Director General has to make a decision which is not necessarily in line with the mandate for his or her Center.

An example of such a decision was the positive response to the request of IITA's host country Nigeria to develop, as rapidly as possible, a hybrid maize variety suitable for the Nigerian conditions. The guaranteed understanding was that the Nigerian Government should stand for all cost involved. Within a record period of three years, a team of IITA scientists had bred a streak virus resistant hybrid variety, for which the Center was given the King Baudouin Award.

The Director General has the final voice in the selection of the scientists for vacant posts and in the determination of their salaries. Usually, for each vacant post, senior scientists make a thorough international search to find the most suitable person and present a priority list of possibly 2 or 3 candidates to the Director General for final selection.

There is eventually a yearly evaluation of each staff member by his or her superior. The evaluation is shown and discussed with the person involved for any comments he or she may have before submitting it to the Director General with the recommendation for any possible adjustment in salary. Any staff member who has a negative evaluation is as quickly as possible discharged from his or her duties under clearly specified administrative rules and regulations.

Our recommendation is that the outgoing Director General prepares a detailed report of his or her work during the past term together with an audited

financial statement for the benefit of his or her successor and of the Board. As this has not been a standing procedure in the past, it has sometimes led to serious misunderstandings.

In the selection of the Director General, the Board should make every effort to find a person who has a clear vision about his or her future input as the leader of the Center and, at the same time, safeguard the ongoing programs as previously approved by the Board in order to prevent abrupt changes and serious repercussions among the staff.

FINANCING OF THE CENTERS

Two types of resources finance the annual budget of each Center: one is a **restricted contribution** and the other one is an **unrestricted contribution**.

Unrestricted resources are provided to finance any part of the System's activities as needed. The donor has no strings attached to their use and they can be used for any purpose within the system. These are encouraged as they allow the System much financial flexibility to deal with emerging opportunities or risks that arise in the normal course of business.

The bulk of these resources come from CGIAR members, although an increasing amount is provided by non-members. The most prominent in the last few years was the Bill and Melinda Gates Foundation, which has given a generous support to the HarvestPlus Challenge Program.

Restricted resources are of two kinds:

- a) Either the donor makes his contribution to the Secretariat, but specifies which Center or Centers should receive them and they may also indicate for what purpose. They are handled by the Secretariat.
- b) Or the donor provides direct financial resources and sometimes staff to a specific Center for a specific purpose or project, the details of which are laid down in an agreed contract between the donor and the Center. The execution of the project is a matter between the Center and the donor and the CGIAR Secretariat is not involved.

Restricted resources are available to finance a donor-specified delineated research activity such as for example breeding of a particular crop, collection of a specific kind of germplasm in a circumscribed area, improving certain farming or livestock systems, setting up water conservation projects. In most cases, these donations have facilitated and accelerated the progress of activities approved and financed by the Group while at the same time they have been in line with the wishes of the donors. The specific destination of such contributions should fall under the agreed mandate of the Center in question.

The Directors General of each Center have considerable freedom to raise proper funds for their Centers. Their impact on the research is far from negligible and may require some special arrangements. For instance, at IITA, where these direct donations amount to $\frac{3}{4}$ of the total budget, the Director General has set up a Contracts and Grants Office (CGO) for the proper preparation and

control of agreements between the donor and the Center and for the signature of the final document. The signature of the CGO on the final contracts is binding to IITA. These finances come from Governments via bilateral programs and from private groups.

Supplementing contributions from members and non-members to finance CGIAR research is a small amount of resources generated by the Centers. These are resources resulting from investment income, sale of assets, and similar undertakings by the Centers. Such Center-generated income averages about 2-4 percent of the total resources available to the CGIAR Centers each year.

In 2004, the unrestricted contributions totalled 195 million US\$, the restricted contributions totalled 242 million US\$, making a total funding to the CGIAR from members and non-members of 437 million US\$. This was supplemented by 16 million US\$ in Center-generated income. Total available resources in 2004 amounted therefore to 453 million US\$. Together they represent the single largest investment for the production of international public goods for poor agricultural communities worldwide.

This investment focuses on the following five priority areas*:

- 1) Sustainable production of crops, livestock, fisheries, forests and natural resources;
- 2) Enhancing national agricultural research systems through joint research, policy support, training and knowledge-sharing;
- 3) Germplasm improvement for priority crops, livestock, trees and fish;
- 4) Germplasm collection, characterization and conservation, as the genetic resources that the CGIAR holds in public trust and makes available to all include some of the world's largest genebanks; and
- 5) Policy research on matters that have a major impact on agriculture, food, health, the spread of new technologies, and the management and conservation of natural resources.

* *Source:* CGIAR Annual Report 2004 – Innovations

For 2004 the expenditures by object were as follows:

- 1) Personnel 45%
- 2) Supplies and services 29%
- 3) Collaboration and partnerships 14%
- 4) Travel 8%
- 5) Depreciation 4%.

Sub-Saharan Africa received as much as 47% of the total resources of the System, which was by far more than any other region.

MANAGEMENT SYSTEMS OF RESEARCH

The best management of agricultural research is a system whereby it becomes an important instrument for the possible allocation, operation and use of natural resources. This is the only single way to provide mankind with well-being.

This basic concept is insufficiently recognized both by policy makers and by private companies. An eloquent proof of this flaw is the lack of allocation that many Governments have in their national budgets for this kind of research. The results of research may take time to be tested, spread and recognized. Publicly elected officers are anxious to show immediate results in order to be re-elected. On the other hand, private organizations spend great amounts in research for immediate proper use and benefit. All this shows a weakness in a democratically organized system.

The high public money support the CGIAR received at the start, and even more so subsequently, was due to the rather rapid results that research was able to provide, thanks to the system under which it operated. This system was quite unique and until then only applied in the unrestricted private sectors, i.e. heavy contributions towards a total of planned resources and well defined objectives, with great freedom of operation for the research staff and its leadership.

Although the principal objective of agricultural research is managing natural resources, especially using and conserving efficiently land and water resources in order to provide sufficient food for all people, the first five Institutes were basically aiming at increasing staple commodity production. In other words, they focused on crop and livestock with a higher inherent genetic production capacity and on improved operational practices under the different ecosystems and physical character of available resources of land and water. Only later they realized that the relationship between higher production and well being was as difficult to establish as is that between hunger and poverty.

The results of the first five Centers were rapid. Their high level scientists worked on well-defined and important issues in a practically virgin environment, where little improvement had been accomplished under the colonial powers. The need for concrete and rapid results was a must, considering the often dramatic situations in their mandated zones.

Today the challenges have become more complex, as there is a felt need to strengthen the collaboration with the target groups for a mutual understanding of their problems and needs and for finding solutions that suit both the scientists and the farmers. A motto of the Group is: "Our founders shared the conviction that the results of scientific breakthroughs, transferred across borders and adapted to local agro-ecological conditions in developing countries, could generate a shift from handouts to hope". **But by which means?**

The lack of an efficient extension system in developing countries is certainly a serious handicap. The two-way chain *research-extension-farm/farm-extension-research* does not exist within the CGIAR. No research, however excellent it may be, is of any use if it does not reach the farmers or is not accepted by the farmers for reasons that can be of the most different kinds. There are cases in which scientists have obtained results which looked very promising, as for example with low cyanide content in cassava. It later turned out to be more a failure than a success, as the texture of the cassava was not appreciated when tested in the farmers' hand before eating and the lack of bitter taste left them little enthusiastic.

A research result needs not only to be tested but also, if accepted, to be disseminated. However, the main and largest target group in the developing agricultural world are small-scale farmers with no possibility to contact the Centers. How can these Centers reach them and by whom?

It happens that scientists in some Centers act themselves as extension agents, bringing their products to the farmers to be tested and possibly applied. This takes time, may not be the right approach and also takes these scientists away from their principal tasks. There is therefore a risk that important breakthroughs only reach a small number of the targets for which they were meant.

This is also so much more serious, as the national extension services in many of the mandated areas, especially in sub-Saharan Africa, are extremely weak and ineffective. The best solution to this problem, as we see it, would be that each Center set up a special Office within its Information Department with trained officers who are strongly connected with the existing national extension systems for the training of its personnel and for providing continuous information about what the Center in question can offer.

If this is only a question of funding, why not allot some of the research money to such an initiative instead of risking that an excellent product never reaches a target group?

Another solution could be some form of association with agricultural schools for small-scale farmers. A modest but very efficient example of diffusion of improved technologies and crops exists in Nigeria and Ghana, where some Leventis Foundation Agricultural Schools are open for English speaking young male and female farmers of good standing in their villages. In these schools IITA research results are constantly applied in practice. The schools receive regular visits from the scientists of the Center who inform teachers and students about their work, bringing simple tools and illustrating new techniques. At the end of the school year, these same students select a specialization and start their activity in their home village. Acting as catalysts, they evoke the interest of neighbouring farmers, who are keen to copy their innovating farming systems. These students can also be trained as extension workers, although this is not the very idea of the program.

Gradually, however, the need of an extension of some kind for the effective transfer and wider application of research results has been realized by the CGIAR. Many Centers have established activities in different ecological zones of their mandated areas, either in the host country and/or in other nations of their assigned region. These activities do not only cover their own specific projects but also Systemwide and Ecoregional Programs and multi-institution Challenge Programs. Although these are under the management of the Centers, they may be in collaboration with local research or development organizations. In most cases, they have a first applied approach using basic research material developed at the headquarters.

There are cases in which a basic research program has to be accomplished at a sub-station, requiring laboratories, service buildings and housing for the scientific staff. These sub-centers provide the farmers in the surrounding area an

opportunity to be familiar with certain research breakthroughs of the Center. They may also organize demonstration fields of the proven results, including research and extension workers' field days. It is a first step towards an extension work, which, according to the Charter of the System, should be the full responsibility of the local Organizations. **But is this sufficient to reach great parts of the mandated area with information of the Centers' work?**

However, no guidelines or general approach have so far been set on paper or, still less, been put into practice. Perhaps the Center Directors in collaboration with the Scientific Council should arrange for a thorough study to be made on the alternative possibilities of disseminating research results of the Centers to farmers, especially in countries with poor extension services and many small-scale farmers?

TRAINING ACTIVITIES OF THE CENTERS

Most of the Centers have three types of training activities:

- 1) The employment of post Doctorate (Ph.D. and equivalent) junior scientists who are assisting senior scientists at the Center in their activities. Often they are able to take major responsibilities and thereby speed up the work of the scientists. They normally stay one to two years, during which time they are deepening their own scientific experience. They may also make an important contribution to research for which they are credited. It gives them also the possibility to be fully acquainted with the programs and the activities of the Centers, which they can use in their future assignments. They receive board, lodging and health insurance at the Center while doing the work of a scientist. Their remuneration is often provided through a special donor contribution and in such case it does not interfere with the finances of the CGIAR.
- 2) Assisting graduate students in their Master's or Doctor's thesis, in agreement with their University Professors, by giving them the opportunity to undertake a part of the necessary work of a research activity of the scientists, while working under their day-to-day supervision. However, any necessary course work for their degree has to be taken at a University. They are usually provided board and lodging by the Center. The number varies from Center to Center, depending on their available facilities of housing them. Again special grants may be obtained from donors for this activity, which may make a contribution to the research work of the Center. Normally, the Centers' scientists who have these graduate students are members of their examination boards, while defending their thesis.
- 3) Providing short courses and seminars on a given subject to a limited number of selected participants, usually 15 to 50 for a period of up to 3 months but usually not more than two or three weeks. The participants are normally given board and lodging at or by the Center.

All three types of training activities could be, and are to some extent, a source of transfer of technology and application of research results.

This particular objective is not always sufficiently pursued, although usually the participants are also made familiar with the ongoing activities at the Center. It could be advisable to have some sort of follow-up organization to help participants in all three types of training activities to be in regular touch with the Centers to keep them informed of ongoing activities and research results. In this way they can act as ambassadors and catalysts for the application and the follow-up of the Center research results.

SOME SELECTED CENTER HIGHLIGHTS

The 15 CGIAR Centers are spread around the world, each with its own mandate and responsibilities. It would be too long here to discuss each Center and its performance. Although we recognize that all of them are making significant contributions in line with the major goals of the CGIAR, we have selected a few typical features from some of them to show some different approaches and personal initiatives in the management system. For further information about them, we suggest that the reader consult their web-sites which provide elaborate information on their activities. (See attached list)

IRRI – THE INTERNATIONAL RICE RESEARCH INSTITUTE

The International Rice Research Institute, in Los Banõs, the Philippines, was the first of the CGIAR 15 Centers to start activity in 1965. Its initial staff of scientists from 8 different countries was then 18. Today the number of international scientists working fulltime on rice reaches the figure of 70. In other words, they have increased in pace with the ever-increasing demand of the crop.

Presently, and certainly for a long time to come, rice is and will be nature's and the world's most important alimentary resource, being the staple food for half the world population. In 1971, the year in which the CGIAR was established, the world counted 3.6 billion people. This figure has now doubled and is expected to reach 9 billion by 2050. Without going so far, we can prospect that in twenty years 4.6 billion people will have rice as their staple food. In order to feed so many mouths, and at the same time leaving the cropped surface more or less the same, rice yields need to increase by 30%. Twenty years is a short period for such a challenging goal.

Fortunately, rice has great flexibility in its production potential. It grows both under flooded and dry conditions, adapts without any special problems to different climates and ecosystems, it is versatile and has produced, with nature's or with breeders' help, thousands and thousands of different varieties out of its original 23 species. A great number of these are already stored in germplasm banks for future crossing, genetic engineering or multiplication. IRRI alone has 80,000 rice accessions in its genebank.

In August 2005, the International Rice Genome Sequencing Project, a publicly funded project, formed by academic centres in 10 countries and led

by Japan, published the seven-year-long final result of its strenuous research work. It is a precious source of information for IRRI's and for all rice breeders as it shows some 400 million clearly mapped base pairs, which together form the genome of *Oryza sativa japonica*, one of three *Oryza sativa* cultivated rice varieties. Thanks to this unravelling of the *Oryza sativa japonica* rice genome it is possible to incorporate many useful traits in much shorter time not only into *Oryza sativa japonica* but into all existing rice races and also into other cereals, such as wheat and maize.

Oryza sativa originated in tropical Asia but developed later into three different eco-geographic races: *Oryza sativa indica*, *Oryza sativa japonica* and *Oryza sativa javanica*. Another species is *Oryza glaberrima*, the rice with red grains and tolerance to several diseases and pests, which originated in Africa and has now been incorporated by WARDA, Africa Rice Center, into a high-yielding new rice variety: NERICA.

China with its long farming tradition is an interesting example when it comes to intensive and successful rice production in collaboration with IRRI. It became a member of CGIAR in 1984. At that time it had already been using some of IRRI's rice varieties. Today, 90% of China's hybrid rice is based on IRRI germplasm. This equals half of the country's rice production. It is furthermore important to note that the country feeds 20% of the world population, but uses only 9% of the world surface. China can therefore stand as a very good example of superb land use and soil management.

In order to achieve a maximum of efficiency and speed to reach the goals in their breeding programs, IRRI scientists, without putting aside the old techniques, make today wide use of new technological advances such as nanotechnology, information and communication technologies as well as transgenic crop techniques. These advanced methods require coordinated input from scientists of distinct disciplines, eco-regions and types of institutions together with organization and cooperation for a prudent management of nature's most appreciated food resource.

BIOVERSITY INTERNATIONAL

During millennia every farmer has been his or especially her own breeder, selecting the best seeds from the year's harvest for a better harvest the following year. It is certainly a good and simple method, however, it is slow and has drawbacks. Today, considering the ever-rising food demand, geneticists use a more rapid tempo, better facilities and a vaster assortment of samples than the few landraces that farmers disposed of. The main advantage is that today's breeders can require their needed gene capital direct from genebanks, and receive it with a detailed characterization of each ordered accession.

The whole world's genetic resources are still very rich but under constant threat of extinction in nature. Biodiversity is the trademark under which **Bioversity International**, initially called **IPGRI - The International Plant Genetic Resources Institute** - was founded some 30 years ago in Rome. Its main office has

now moved to Maccaresse, a small town north of the capital. Besides, Bioversity has offices in more than 20 countries worldwide and a total staff of around 300. It is the world's largest international institute dedicated solely to the conservation and use of plant genetic resources and the establishment and management of genebanks.

A genebank can be a massive collection of seeds of one or more cultivated plants and their wild relatives, kept in safe custody in buildings with refrigerators and quick reproduction facilities or it can be a single field of a few labelled plants. Many crops produce seeds that can store for longer periods under cold conditions like cereals and legumes without losing their viability, others, like roots and tubers, have to be regenerated each year in the field or *in vitro*. These accessions are not allowed to run out of stock as the bank always needs to have samples available to breeders, for reproduction use and for future generations.

Genetic material can be stored in three different ways: *in situ*, *ex situ* and *in vitro*.

In situ conservation means growing and conserving plants in their natural habitat: on farms, in gardens, in nature everywhere. It is considered an ideal strategy if carried out carefully.

Ex situ is the most common practice, especially for the conservation of seeds for longer periods. The seeds are dried, fumigated, packed and stored at different temperatures according to the length they are intended to stay viable. Bioversity is presently developing strategies and methods to organize and structure *ex situ* germplasm management practices.

Some plants do not produce seeds or can not be propagated by seeds but by bulbs, cuttings, roots or tubers. The only way to keep them alive is by replanting them every year by costly time-, energy- and space-consuming procedures, involving great risk of human error and loss of material.

For this kind of germplasm there exists a more sophisticated solution: *in vitro*. It is a tissue culture method with the germplasm material kept in glass tubes for short to medium term periods. The growth of the plant in the glass tube can be slowed down either by a reduced incubation temperature or by the manipulation of culture media or by the combination of both methods. Some cultures can be maintained at low temperatures as long as 2 or 3 years.

National programs in developing countries often lack the structural backing and trained personnel, adequately equipped laboratories, including cold storage facilities, as well as distribution vehicles to keep their collections alive. Their collections are therefore at great risk. When a seed is lost, in the soil, on the plant or in the genebank, it is lost forever. A central organization such as Bioversity is therefore of utmost importance to safeguard this most precious treasure in nature named the flora.

The Norwegian Government has recently restructured and generously opened to all genebanks in the whole world an abandoned coalmine in Svalbard, at 78° north, to hold duplicated accessions of all their existing precious germplasm heritage. This deposit behind two air-lock doors and inside lined with a meter

of reinforced concrete will provide a secure safe for these millions of dormant genes at a temperature of -18°C . However, genetic material will only be used in case other genebanks are destroyed as a consequence of climatic, environmental, nuclear, bellicose or terrorist catastrophes. Responsibility for depositing and retrieving material, if necessary, has been entrusted to the Nordic Gene Bank, based in nearby Sweden. CGIAR has welcomed the initiative and announced that it will commit to this former coalmine copies of its enormous germplasm heritage.

Still remains Bioversity's task to guarantee the genetic integrity of its material, which today amounts to almost 7 million accessions stored in 1400 collections around the world. It receives material from the Centers, which often have their own genebanks and, as Bioversity, organize exploration missions.

Africa is a continent with the greatest "reservoirs of genetic variability" but other reservoirs still exist elsewhere. These reservoirs are areas where spontaneous mutations have occurred undisturbed at different rates and at different traits of plants over millions of years and created diversity among the same species through natural selection.

Diversity has three main levels: the combinations of species that make up different ecosystems, the number of different species and the different combination of genes in species. These reservoirs are gold mines for plant explorers as they contain plants, which have developed resistance and tolerance to diseases, pests, or environmental or climatic stresses as drought.

Many precious species are now at serious risk because of intensive monocropping or urbanization. The widespread adoption in modern farming of only a few improved varieties has narrowed the genetic base of food crops and caused the loss of many landraces. Today an average loss of 100 species per day during the next 20-30 years exceeds the historical rate of extinction by 1000 times. A quarter of the earth's total biological diversity amounting to 1 million or more of species is seriously affected by this threat. Considering only forest resources, the expected losses of tree species are estimated to be around 8% over the next 25 years.

The collection and conservation aspects are therefore fundamental, and Bioversity's work to store what otherwise could be future losses can never be measured and appreciated to its full extent.

IITA – THE INTERNATIONAL INSTITUTE OF TROPICAL AGRICULTURE

Sub-Saharan Africa is a diversified continent but with a common denominator: its urgent need of more and better food. When the third CGIAR Center: **the International Institute of Tropical Agriculture, IITA**, was established in 1967 in Nigeria, with the not easy task to improve – in quantity and quality – food production in the tropics and subtropics, the mandated crops which fell to its

lot were several: cassava, yam, coco yam and sweet potato among the roots and tubers, cowpeas and soybeans among the legumes and maize and rice among the cereals. Further, its mandate also included improved farming systems, implements and soil management, conservation and processing methods as well as maintenance of germplasm. It has now the largest budget of all the Centers.

The task of IITA scientists is therefore both wide-ranging and complex. Inside their working area they have 1000 ha of land, sufficient water resources, all necessary infrastructures as well as housing. Several substations and other work sites are located in Nigeria and other countries in sub-Saharan Africa.

At the beginning of IITA's pioneering activity, a little cassava mealy bug was accidentally introduced into Africa from Latin America. It was noticed for the first time in Zaire in 1973 by one of IITA's cassava breeders. By 1979 it had reached Nigeria and it did not take long before it had invaded the whole cassava belt as far as Senegal, completely destroying whole plantations and thus depriving great part of the population of their staple food. There was no way to stop its ravaging, as Africa had no predatory insects to keep its quick proliferation under control.

Identified as a *Phenacoccus manihoti*, the Center decided to start an immediate action to find predatory insects and keep its diffusion under control, as happened naturally in the American continent, where the mealy bug had various enemies. IITA contacted the International Fund for Agricultural Development, IFAD, in Rome for a special grant in order to be able to make a worldwide search for predatory enemies to be introduced into the African continent. This was the first time in CGIAR history in which a Center started a successful biological control program.

Some predators were found. To start with it was a little wasp, later three more plus a parasite from Paraguay were added and tested. The program had them multiplied at the Center and then shot from the air in mini parachutes over the most invaded areas. From there they spread, multiplied and enjoyed their plentiful meals of cassava mealy bugs. Consequently, there was no need of using pesticides, which should have destroyed also the predatory enemies, and thus there was no additional cost but only benefits for the farmers.

The quick action taken by IITA and the exceptional results of the Biological Control Program opened the way to similar pest control programs at IITA. A sub station was built in Benin where most of the work was concentrated. In collaboration with national agricultural programs and other international and national organizations in sub-Saharan Africa, IITA then completed biological control programs against the cassava green mite, the mango mealy bug and the water hyacinth.

Studies based on field trials, socio-economic surveys and information from national programs to assess the economic impact have shown very high net benefits of all these biological control activities.

A survey was undertaken at the end of last century among 39,000 households to evaluate the hyacinth infestation in the lagoon region of southern Benin. Its objective was to establish the overall impact of the biological control program

when using the water hyacinth weevil, and to which degree it affected the income of each household. The total economic loss from the water hyacinth was estimated at US\$ 83.9 million, mostly from fishing (64%) and in the fish trade (26%). The cost of the biological program of US\$ 2.09 million was mainly for operational costs and salaries of international and local staff, since the rearing of the water hyacinth weevil, which destroyed the infestations, required little equipment and space. Based on the benefits (US\$260 million) and the cost (US\$2.09), the benefit cost ratio was estimated at 124:1, not including the rather high range of ecological and human health benefits involved, as no chemical inputs were needed.

As a matter of fact, the income of the population had increased by US\$ 30.5 million, mostly from fishing (72%) and from trading food crops (17%), and this increase was entirely attributed to the reduction of the water hyacinth cover and thus represented the benefit of biological control.

The weevils were later exported, reared and released in much larger areas in similar lagoon systems (Burkina Faso, Côte d'Ivoire, Ghana, Nigeria, Tanzania and Uganda), but at much lower costs and thus at an even higher benefit-cost ratio.

ICARDA – THE INTERNATIONAL CENTER FOR AGRICULTURAL RESEARCH IN THE DRY AREAS

The very idea of establishing a Center in the drought-haunted areas of the world was conceived in 1972, when a Review Mission commissioned by the CGIAR reported a great potential threat of food shortages and loss of natural resources and its global implications. When ICARDA, which stands for **the International Center for Agricultural Research in the Dry Areas** was first established, it was based in three countries: Lebanon, Iran and Syria. But as the political situation became unstable in the first two, Syria became the sole host in 1975. It proved to be a good choice.

Situated on 948 ha of farmland provided by the Syrian Government some 30 km south of Aleppo, ICARDA's influence stretches far beyond its boundaries and includes the areas of Central and West Asia and North Africa known as CWANA as well as other developing countries with subtropical and temperate dry areas. In all, its mandate covers one third of the land surface of our earth, and much of its material has also found practical use in some industrialized countries.

ICARDA's recently redesigned portfolio focuses on human welfare, agricultural productivity and economic growth. The main barrier, that its 100 and more international staff have to overcome in their breeding programs, are high temperatures and drought. So far, science has not shed light on what makes a plant drought tolerant. However, local landraces and their wild progenitors often provide drought tolerant traits and therefore serve as basic material in their breeding.

Another intolerance problem affecting crops on around 20% of the land in WANA countries is soil salinity. The relationship between drought and salinity tolerance, if any, varies among the plants and have now been evaluated for most of ICARDA mandated crops.

These crops include durum and bread wheat (CWANA accounts for the largest wheat growing area in the world, about 80% of the world's durum is grown there, but the yields are still low), barley, lentil, chickpea and faba bean.

Pasture is another part that weighs heavily on ICARDA's mandate. Encompassed by ICARDA research in the WANA area alone are some 20 million square-kilometres of pastures.

To restore this vast but overgrazed pasture land has become an urgent matter. The area has almost half a billion head of sheep and other small ruminants and this number is steadily increasing as grazing, apart from being a deep-rooted tradition, has lately become popular among young landless people without any better expedient for their living.

To put a halt to the over-grazing and erosion problem, ICARDA pasture scientists work simultaneously on several levels: improving the pastures, better and more forage, collection and multiplication of suitable seeds for rejuvenating the pastures and involving the shepherds/farmers in their work. The management of the various production systems makes it necessary that all the research components are put into a single farming systems perspective, to be eventually managed by the farmer/shepherd as his responsibility.

This forces ICARDA scientists to work closely together, overlapping their research activities and improvising new ones. The barley breeders work on special high-yielding barley with long and soft stalks and abundant heads, as that is the feed farmers need for their sheep. Legume breeders have projects that include crossing wild lentils and other wild legumes with improved varieties for a better forage.

The pasture scientists work either as geneticists, ecologists, agronomists, engineers or extension agents to involve the farmers/shepherds in their pasture improvement process, which is probably the hardest part. They have already identified several seeds, which need multiplication before being spread on the pastures. They have created simple, hand-driven pod sweepers that farmers can reproduce and use to harvest the pods in their multiplication fields. They have identified that the low productivity of the land is also caused by a lack of phosphorus and added small doses of phosphate to it. In all this complex work process ICARDA research staff has involved national research institutes and extension agencies.

A continuing theme of the ICARDA program has been to keep close contact with the farmers, to talk and to listen to them, to carry out on-farm experiments to find out what works with them and what does not, in order to feed any positive result back into their research. Because, according to ICARDA scientists, studying drought, salinity or overgrazing of pasture land just as a technical problem is not so difficult as conveying the research results to the human factor for approval, acceptance and application.

CONCLUDING REMARKS

Although the CGIAR system is generally appreciated for the impact it has had on agricultural and rural development, from time to time certain criticism is raised about its work and especially about the large amount of money devoted to it.

Its superstructure, as described in this Chapter, has gradually grown to its present rather complex nature. The change from a simple head office with a technical advisory committee to its present number of Centers and central offices is a rather normal process in an international organization with members of different political, economic and social background and interests. Its effect on the work of the Centers may have been marginal and, in fact, it may have increased the administrative work of providing the central offices with the necessary information.

The real effective use of the resources of the System rests with the Centers and in particular with their Director General and staff. The selection of the right persons is therefore essential. If mistakes are made in this aspect, the Board of Trustees or, in last instance, the CGIAR Secretariat, on behalf of the donors, should take fast corrective action.

Overtime it has happened that a mandate of a Center was not appropriate or became obsolete because of research developments elsewhere at a national or international level. In such cases, corrective action has been taken by either closing a Center and/or transferring its activities to another Center.

Most important for the activities of all Centers is the fact that all contributions of the donors are voluntary and that each donor can stipulate to which Center the contribution should be allocated. If a Center runs short of donors, it has automatically to curtail its research activities or it must be terminated. It is noted that a number of cost-benefit studies have been made by independent scientists on research of the Centers. In practically all cases, they showed a very high positive cost/benefit ratio. Perhaps more of these studies in collaboration with Universities could be made at the instigation of the Centers or the Science Council, especially for the fulfilment of Master's or Doctor's theses.

We find it a positive sign that the number of donors has steadily increased and with them the total voluntary contributions. This is no doubt a valid proof of international appreciation for the work produced by the CGIAR System through its Centers and its 8000 international and other staff.

However, with all the agricultural research that is presently undertaken by both public and private enterprises, the CGIAR in its quality of International Organization may well take it as a major task to function as an objective screening house, i.e. to collect, examine, interpret and evaluate these results against the five priorities which prevail for all the Centers. (see page 190).

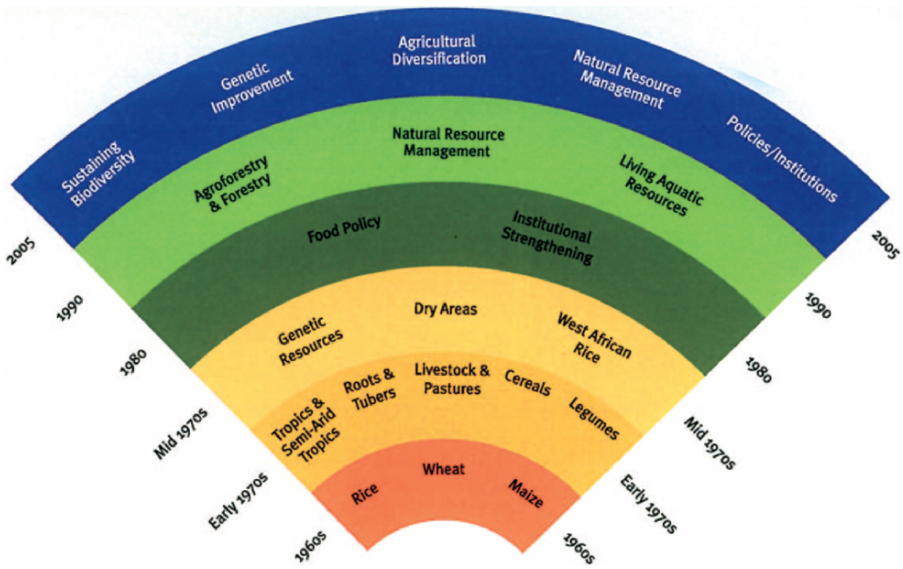

Figure 1. GGIAR research agenda with the year in which mandate was initiated. (see Color Plate 3 following p. xiv.)



Figure 2. Map showing headquarters and other locations of GGIAR centers. (see Color Plate 4 following p. xv.)

REFERENCES

- The Consultative Group on International Agricultural Research (CGIAR) – THE CHARTER OF THE CGIAR SYSTEM, November 8, 2004.
- Science Council – CGIAR: Science for Agricultural Development – Changing contexts, new opportunities, 2005.
- FAO – Rice is Life – International Year of Rice 2004 and its Implementation, October 2005.
- International Research in Agriculture – Consultative Group on International Agricultural Research, New York, 1974.
- Scientists of the CGIAR – November 2005.
- Research for Sustainable Development: From Words to Action CGIAR Annual Report 2002.
- System Priorities for CGIAR Research 2005–2015, Science Council Secretariat, December 2005.
- Science Council Brief – CGIAR – Summary Report on System Priorities for CGIAR Research 2005–2015, Science Council Secretariat, FAO, Rome, January 2006.
- Innovations – Consultative Group on International Agricultural Research – Annual Report 2004.
- IPGRI – GeneFlow – A Publication about Agricultural Biodiversity, 2005.
- IPGRI Issues on Gene Flow and Germplasm Management, 2005.
- ICARDA Annual Report 2005.

WEBSITES

- International Center for Tropical Agriculture (CIAT) www.ciat.cgiar.org
- Center for International Forestry Research (CIFOR) www.cifor.org
- International Maize and Wheat Improvement Center (CIMMYT) www.cimmyt.org
- International Potato Center (CIP) www.cipotato.org
- International Center for Agricultural Research in the Dry Areas (ICARDA) www.icarda.org
- International Crops Research Institute for the Semi-Arid Tropics (ICRISAT) www.icrisat.org
- International Food Policy Research Institute (IFPRI) www.ifpri.org
- International Institute of Tropical Agriculture (IITA) www.iita.org
- International Livestock Research Institute (ILRI) www.ilri.org
- Bioversity International (Combining the International Plant Genetic Resources Institute (IPGRI) www.ipgri.org and International Service for National Agricultural Research ISNAR)
- International Rice Research Institute (IRRI) www.irri.org
- International Water Management Institute (IWMI) www.iwmi.cgiar.org
- West Africa Rice Development Association – The Africa Rice Center (WARDA) www.warda.org
- World Agroforestry Centre (ICRAF) www.worldagroforestrycentre.org
- WorldFish Center www.worldfishcenter.org

CHAPTER 11

LINKING PRIORITIES AND PERFORMANCE

Management of the USDA Agricultural Research Service research portfolio

EDWARD B. KNIPLING¹ AND CAIRD E. REXROAD, Jr.²

¹Administrator and ²Associate Administrator, Agricultural Research Service, United States Department of Agriculture, Beltsville, Maryland, USA

INTRODUCTION

The agricultural system in the United States is a complex structure that interweaves a myriad array of high- and low-tech techniques for livestock and crop production. This system has evolved – and continually changes and advances – because of contributions and innovations from many players, including private industry, public research organizations, and agricultural producers.

ARS online

ARS maintains an extensive website that contains links to every one of its National Programs, research facilities, and current research projects, as well as updates on short and long-range research plans, staff contacts, and other useful information. The main website is found at www.ars.usda.gov.

The United States Department of Agriculture (USDA) is a key participant and collaborator in agricultural research and development, and supports a broad range of research, production, and management programs for the benefit of domestic and international agriculture.

USDA mission

USDA provides leadership on food, agriculture, natural resources, and related issues based on sound public policy, the best available science, and efficient management. Six strategic goals support this mission:

- Enhance international competitiveness of American agriculture
- Enhance the competitiveness and sustainability of rural and farm economies

(continued)

 USDA mission—continued

- Support increased economic opportunities and improved quality of life in rural America
- Enhance protection and safety of the nation's agriculture and food supply
- Improve the nation's nutrition and health
- Protect and enhance the nation's natural resource base and environment

The USDA was established by the Organic Act of 1862, which directed the Commissioner of Agriculture “to acquire and preserve in his Department all information he can obtain by means of books and correspondence, and by practical and scientific experiments,” and to write reports for the President and Congress. The scope of USDA's agricultural research programs has been expanded and extended more than 60 times since the Department was created. In the 1940s, to better support the war effort, USDA's various research components were brought together into the Agricultural Research Administration (ARA), and in 1953, the ARA was reorganized and renamed the Agricultural Research Service (ARS).

AGRICULTURAL RESEARCH SERVICE

ARS is USDA's principal in-house science research agency, and as a Federal agency, it is tasked with conducting publicly funded research for the benefit of the nation. To meet this mission, ARS has developed a transparent system for developing and managing the Agency's research priorities. This system requires frequent assessment and input from internal and external sources to ensure that ARS continues to generate relevant, significant, and timely scientific information. This information is used by stakeholders, including agricultural producers, food processing industries, natural resource managers, and universities and other nonprofit research institutions. The larger universe of USDA beneficiaries, customers, and stakeholders includes US consumers, other Federal agencies such as the Food and Drug Administration and the Environmental Protection Agency, and international markets.

 ARS mission

ARS conducts research to develop and transfer solutions to agricultural problems of high national priority and provide information access and dissemination to:

- Ensure high-quality, safe food and other agricultural products
- Assess the nutritional needs of Americans
- Sustain a competitive agricultural economy
- Enhance the natural resource base and the environment
- Provide economic opportunities for rural citizens communities, and society as a whole

ARS is one of four agencies that make up USDA's Research, Education, and Economics (REE) mission area. Another REE agency, the Cooperative State Research, Education, and Extension Service (CSREES), administers extramural



Figure 1. ARS locations. (see Color Plate 5 following p. xv.)

funding programs, including the National Research Initiative (NRI), USDA’s primary competitive research grants program for extramural investigator-initiated research into agricultural science. However, federally funded intramural research, the principal focus of this chapter, is the responsibility of the ARS.

Management of the ARS national research programs is headquartered in Beltsville, Maryland—also the location of a sizable ARS research facility—which is in close proximity to USDA headquarters in Washington, DC (Fig. 1). There are over 100 ARS laboratories and locations around the United States, Puerto Rico, and the US Virgin Islands, and four laboratories overseas. The laboratories are grouped into eight geographical areas, each of which is under the direction of an Area Director. Laboratories are led by Research Leaders, who oversee a number of related research projects, and who are responsible for ensuring the quality and performance of each project. The number of facilities in each Area varies, as does the research focus, but all ARS scientists are tasked with tackling agricultural issues of regional and national significance. These issues are identified and selected through a national priority-setting process involving scientists, customers, stakeholders, and program officials. Scientific direction is provided by the National Program Staff (NPS) located in Beltsville.

The ARS workforce of around 9,000 staff members includes some 2,500 career scientists and postdoctoral associates; the balance includes executives, managers, support scientists, technicians, and other support personnel. Approximately 1,000 research projects are underway at any one time, ranging in scope and size, but each one passes through the same rigorous approval and monitoring process.

Research conducted by ARS is supported by an annual appropriation of US\$1.1 billion (fiscal year 2007), and is a critical component of maintaining a secure, safe, competitive, and sustainable agricultural production system. A key part of the ARS budget and planning process is careful management of limited resources so that all of its programs are successfully supported. Each component of the budget is assessed annually to make sure it receives the appropriate level of funding in light of how events have unfolded during the previous fiscal year. For instance, in 2008, the proposed ARS budget has increased funding for research on biofuel initiatives, animal genomics and the preservation of animal germplasm, plant genomics and the preservation of plant genetic resources, food safety surveillance and detection techniques, invasive species, emerging livestock diseases, crop diseases, obesity research, and water resource management.

ARS NATIONAL PROGRAMS

In the mid-1990s, ARS revamped the way it manages its research portfolio; the 1,000-plus research projects were aligned into National Programs (NPs) that encompasses all the research of the Agency. There are now 19 NPs grouped into four program areas (see box).

Each of the four program areas is managed by a deputy administrator, and each NP is led by a team of National Program Leaders (NPLs). Currently, some 30 NPLs are responsible for planning and developing research strategies to address critical issues affecting American agriculture. These research strategies are implemented through the development of specific Action Plans designed for each NP, which will be discussed in more detail later.

ARS National Programs	
<p>Nutrition, Food Safety/Quality</p> <ul style="list-style-type: none"> • Human nutrition • Food safety (animal and plant products) • Quality and utilization of agricultural products 	<p>Animal Production and Protection</p> <ul style="list-style-type: none"> • Food animal production • Animal health • Veterinary, medical, and urban entomology • Aquaculture
<p>Natural Resources and Sustainable Agricultural Systems</p> <ul style="list-style-type: none"> • Water Availability and Watershed Management • Soil and Air Resource Management • Bioenergy • Agricultural Waste and Byproduct Utilization • Pasture, Forage, and Range Land Systems • Agricultural System Competitiveness and Sustainability 	<p>Crop Production and Protection</p> <ul style="list-style-type: none"> • Plant genetic resources, genomics, and genetic improvement • Plant biological and molecular processes • Plant diseases • Crop protection and quarantine • Crop production • Methyl bromide alternatives

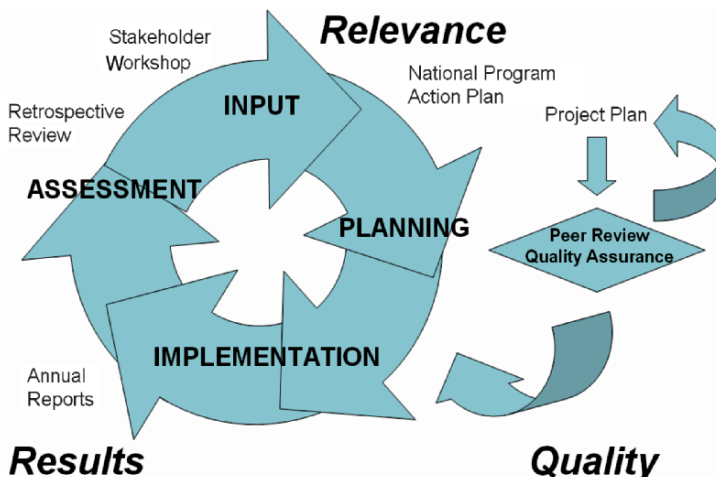

Figure 2. ARS 5-year research program cycle. (see Color Plate 6 following p. xvi.)

ARS 5-YEAR RESEARCH PROGRAM CYCLE

Assuring relevance, quality, and results

Each Presidential administration sets its own goals and priorities, which USDA then incorporates into a departmental Strategic Plan; ARS, in turn, fulfills its role as a Federal agency by ensuring its research addresses the goals and priorities outlined in the USDA Strategic Plan. ARS begins this process with the development of its own strategic plan, which provides the framework for presenting the ARS budget and reporting accomplishments, and for tracking ongoing activities (Fig. 2).

Specific protocols are in place to ensure that ARS work is relevant to either immediate or long-term scientific efforts, and that it is of the highest quality. These protocols involve extensive planning by ARS, and input from staff, the external scientific community, stakeholders, customers, and government.

NATIONAL PROGRAM WORKSHOPS

NPS define and direct the ARS NP. Each program has a 5-year cycle that begins with a National Program Workshop (NPW), which defines the purpose and goals of the NP. In these workshops, a cross section of customers and stakeholders participate in identifying and prioritizing research needs for each program. Due to logistic issues, the NP cycle schedules are staggered, so that they are all at different points in the 5-year cycle at any given time.

ARS Beneficiaries, customers, stakeholders, and partners

- **Beneficiaries:** Individuals whose well-being is enhanced by ARS activities
- **Customers:** Individuals (agricultural producers or processors) or organizations directly using ARS developed knowledge, technologies, or services
- **Stakeholders:** All customers are stakeholders. In addition, stakeholders are organizations or individuals with an interest in the work of ARS, including: advocacy groups, commodity organizations, national and international trade organizations, Federal government agencies, ARS employees, consumers, etc. even if they do not directly use the Agency's products
- **Partners (and cooperators):** Organizations that ARS works with collaboratively, including research groups located at universities, other government laboratories, and in the private sector

To ensure ARS research is relevant, input is obtained from several groups to help identify the major issues confronting American agriculture and related industries. In this ongoing interaction with stakeholders, ARS receives the view of:

- Each Presidential Administration and each Secretary of Agriculture. While the core research activities remain relatively constant from year to year, changing Administrations highlight different priorities. For example, the current Administration has placed great emphasis on research issues related to trade enhancement. These priorities are generally expressed in budget initiatives (requests for additional funding to expand research in the area of interest).
- A wide array of customers, stakeholders, and partners who represent the spectrum of the national agricultural enterprise. These may be groups like the National Cattlemen's Beef Association, the United Soybean Board, food processors, nutritionists, environmental groups, or other interest groups. Representatives from these groups identify their key issues/problems requiring technological solutions, which are then taken into consideration during the program planning process that produces the NP research agenda. The scientific community – national and international, public and private – is part of the discussion about where to most effectively and efficiently deploy national research capabilities. ARS scientists and managers bring their background and experience into this decision-making process. Their knowledge of what ARS has done or is doing, coupled with their understanding of related work being conducted by universities, private research laboratories, and other institutions, helps the Agency meld the input from all the above identified sources into a coherent research agenda that addresses the highest priority issues.
- Beneficiaries such as American citizens, who provide input about agricultural issues they rank as research priorities through communication with their Congressional representatives or through direct communication with ARS staff.

NATIONAL PROGRAM 5-YEAR ACTION PLANS

In developing 5-year Action Plans, NPLs evaluate and assess the needs and priorities exchanged at the NPWs, and identify research priorities for each NP. Once these priorities are identified, the NP team responsible for each program

then develops the 5-year Action Plan to guide the overall research for that program.

Listening to stakeholders

Although nurseries and floriculture produce the third-largest cash crop in the United States, they have traditionally received little Federal support for research and development. In 2000, ARS partnered with industry and universities to create the Floriculture and Nursery Research Initiative. This Initiative resulted from 5 years of survey and discussion among private industry, academic scientists, and government researchers, and was fine-tuned through the efforts of a joint working group of industry leaders. Federal attention to the issues and research goals identified in this Initiative has been critical to the continued success of environmental horticulture.

QUALITY: IMPLEMENTING THE PLAN

Developing project plans

After the research priorities, goals, and 5-year Action Plans have been developed for each NP, NPLs assign one or more of the specific research objectives and allocate funds to lead scientists or research teams. These individuals are tasked with devising a project plan that addresses – either with basic, applied, or developmental science – the assigned objective(s) to help reach the goals outlined in the NP with which that project is aligned. A robust Project Plan defines and outlines research approaches, defines interactions with other team members, enhances scientist productivity and impact, and creates opportunities for working with other ARS groups doing related research. Project Plans are the foundation of ARS research, and serve as working agreements between NPS, line management, and the science teams.

All Project Plans must meet stringent criteria for scientific purpose and methodology. The primary purpose of the Project Plan must be to address a research challenge outlined in one of the NP 5-year Action Plans, using the best available science to do so – not just to study an issue to satisfy the investigator's personal curiosity, or to pursue research because it presents a new or novel challenge, if the results would not substantially contribute to a research priority already identified by ARS.

A targeted Project Plan begins with a concise research purpose statement. This rationale is presented in the context of both the specific NP Action Plan and the larger body of scientific knowledge. The Plan identifies the target group of customers and stakeholders who will benefit from this research, and provides a scientific survey of the topic, including a critical review of relevant literature. The Project Plan also lists the scientists who will be conducting the research, including their qualifications and prior professional accomplishments.

ARS research collaboration

To fulfill its mission, ARS looks for opportunities to partner with the private sector, other Federal agencies, State and local governments, and universities. These partnerships are designed to augment research programs, expedite the transfer of research results to the private sector, exchange information and knowledge, stimulate new business and economic development, enhance US trade, preserve the environment, and improve the quality of life for all Americans.

ARS establishes Specific Cooperative Agreements (SCAs) with universities and other research institutions. In these agreements, ARS funds extramural research by laboratories that have expertise to help carry out project objectives. ARS also implements and coordinates large-scale research consortiums. The US Wheat and Barley Scab Initiative is one such effort; 20 state universities and more than 40 national wheat and barley stakeholder organizations have been working together with ARS funding support since the late 1990s to battle wheat scab.

A Cooperative Research And Development Agreement (CRADA) links ARS scientists with external industry researchers, and is the mechanism by which private sector partners provide funding and/or in-kind resources to ARS. This arrangement allows Federal laboratories and businesses to form commercial partnerships that help move new technologies into the marketplace. ARS scientists and companies work together to develop a research plan that is consistent with the Agency's mission, and ARS scientists collaborate with private firms to help ARS technologies to a commercial stage. A CRADA allows a company first rights in negotiating exclusive licenses to any inventions that emerge under the agreement. The objective of the CRADA is to expedite the transfer of federal research activities to the private sector to enhance the global and domestic competitiveness of American agriculture.

The most critical section of the Project Plan presents research approaches and procedures. In this section, scientists clearly describe their experimental strategy, illustrate how their stated objectives can be achieved, and demonstrate that the proposed research protocol uses appropriate and technologically sound approaches and methods. The specific responsibilities of each investigator are listed, along with research timetables and protocols. In addition, project management, project evaluation, contingency plans, and details of any collaboration are outlined.

A series of critical milestones and outcomes must be clearly identified and characterized. This includes identifying the overall projected results and impacts of the project after its completion, designating team members responsible for milestones, predicting significant intermediate research accomplishments, and reinforcing the overall logic and organization of the experimental plan. Expected milestones and outcomes are stated in discrete modules, not as a desired continuum of progress. Reporting on these milestones and outcomes is a central component in the completion of the annual status updates that must be submitted for each project (to be discussed in more detail later).

PEER REVIEW AND THE OFFICE OF SCIENTIFIC QUALITY REVIEW

After the lead scientist has completed the Project Plan, it is reviewed by line management, including the research leader and Area Offices, and submitted for peer review. Peer review is an independent, external, and expert evaluation

of the scientific and technical merit of each prospective ARS Project Plan to ensure scientific quality and enhance its chance of success. ARS regards peer review as an integral part of the Agency's overall scientific program, and works with its scientists to refine and revise Project Plans as appropriate in response to the recommendations of the peer review panel. Sound and credible scientific peer review improves the quality of research ideas, approaches, and techniques, and encourages ARS scientists and staff to explore new thinking, new ideas, and alternative approaches to research issues. Since NPS has already agreed to fund the project under review, this process does not affect the selection or rejection of any project, and does not affect allocated funding levels. Peer review does provide an additional level of assurance, transparent to stakeholders and policy officials, that ARS research will be conducted appropriately and in line with accepted scientific methods.

The Office of Scientific Quality Review (OSQR), which was established in 1999 to manage and implement the ARS peer review system for research projects, assembles the organization and composition of panel members to conduct peer reviews. Peer review panels are made up almost entirely of non-ARS scientific professionals, including an external Panel Chairperson, with expert knowledge pertinent to the research being reviewed. Each panel reviews up to 15 Project Plans (although typically they review 10–12), all of which relate to a given NP or broad component thereof. In their evaluations, they assess each Project Plan's research methodology, probability of success, and scientific merit. The peer review panel then generates an "action class" recommendation (see box).

Project plan action classes

- No revision required, Project Plan is already at its highest quality level, and is feasible as written
- Minor revision is required to increase quality to its highest level, but the Project Plan is feasible as written
- Moderate revision is required to increase quality to its highest level, but the Project Plan is feasible as written
- Major revision is required to achieve its highest quality level, and the Project Plan is not feasible as written
- The Project Plan is not feasible, has major flaws or deficiencies, and cannot simply be revised to produce a sound product

The peer review process gives researchers the opportunity to obtain constructive feedback from their peers on ways to improve the scientific quality of their projects. The review criteria assure that ARS research scientists develop carefully conceived Project Plans that incorporate three key elements of research planning: (1) sufficient project approaches and procedures; (2) a reasonable probability that projects will be successfully completed, and (3) demonstrable merit and significance as projects align with the National Program Action Plan. When major revisions are required, Project Plans are sent back to Lead Scientists with suggestions on what improvements are needed to win approval. If revised Project Plans are

rejected, management takes action to reallocate human and fiscal resources and/or redirect the focus of the research so that it will result in an acceptable plan.

After a Project Plan has been reviewed and evaluated, OSQR distributes the results to appropriate ARS staff. The lead scientist is responsible for implementing the research program. This includes evaluating and documenting the progress of the Project Plan through its 5-year cycle, and providing information on the progress being made towards meeting customer needs. The research leader and lead scientist(s) prepare the necessary reports to both the NPS and line management, and prepare research papers and summaries of the project research findings for publication. Support scientists play a number of roles in a Project Plan: contributing expertise to one or more objectives within a project, serving as a member of a research team responsible for the successful conduct of the research, and assisting with the development of papers, technology transfer opportunities, or other products originating from the research project, as appropriate.

The maize genome database: a work in progress

The collaborative process that ARS used to establish and achieve its research goals takes time, energy, and commitment. The development of the Maize Genetics and Genome Database is a key example of a shared mission—and a shared success.

Corn is one of the leading crops in the United States, and a large number of public and private sector stakeholders actively pursue maize-related research and development interests. Corn is a valuable food and feed export commodity. It is also used domestically in biofuel production, and researchers are developing methods for using all the plant's available biomass—stalks, roots, leaves, and all—in the production of biofuels. Investigations are also being conducted to enhance traits that would further the development of corn as a sustainable crop requiring limited production inputs—less irrigation, and fewer applications of fertilizers and pesticides.

For years, corn stakeholders have highlighted the need to identify and describe the complete maize genome and the need to make this information freely available to scientists, growers, processors, and consumers. This goal received a major boost in 1998 when the National Plant Genome Initiative (NPGI) was established as a coordinated national plant genome research project. Various Federal agencies partnered in this effort. As part of USDA's contribution, ARS agreed to support the development of a first-generation, Web-based genome database at Columbia, Missouri, that would serve as the centralized location for the storage and access of maize genome information.

This project fell under the management of NP 301: Plant Genetic Resources, Genomics, and Genetics Improvement, which included research components on crop bioinformatics, genomics, and genetic improvement. Starting in 2001, National Program Leaders worked with scientists in Ames, Iowa; Columbia, Missouri; and Iowa State University to develop a plan for the next-generation maize genome database needed to handle high-throughput genomic data. After completion, this database would become publicly accessible to users via the Internet, and serve as a model for other crop genome databases.

The research reached a milestone in 2006: The Maize Genetics and Genomics Database (MaizeGDB) was up and running to serve the maize (*Zea mays*) research community by making a wealth of genetics and genomics data available through an intuitive Web-based interface. With the databases' successful establishment, the NP 301 Program achieved one of the Actionable Strategies in the ARS Strategic Plan: Maintain genetic and genomic databases and effective "bioinformatic platforms" that distribute genomic information via standard software from the Internet. External reviewers were impressed with ARS project outcomes, and strongly recommended that ARS continue this database development and management as a service to the genomic research community.

ASSESSING PERFORMANCE AND RESULTS

Assessing performance at ARS involves more than simply measuring technical inputs and outputs. It is hard to develop measures for evaluating the impact of basic science research because so many factors come into play before basic science is incorporated into applied methodologies or production processes with quantitative value. Depending on legislative and executive mandates and on the process under review, ARS protocol for research assessment has incorporated multiple processes and mechanisms that range from fairly straightforward procedures to multistep assessments.

Annual project reports

Internal accountability begins with input from every lead scientist, who is required to submit an annual progress report for their Project. This Annual Report asks for information about research progress, any impacts of this progress, and any publications that have resulted from the research. These reports, in turn, provide information used by the NPLs in the compilation of annual reports assessing the yearly progress that each NP has made in meeting the goals set in their 5-year Action Plans. These reports are available on the Internet at www.ars.usda.gov.

Retrospective reviews

In addition to annual progress summaries, the NPs are subject to another level of review near the end of the 5-year Program cycle. These reviews verify the scientific impact and programmatic relevance of the work conducted under each NP Action Plan. NP teams provide external retrospective review peer panels with accomplishment summaries for each NP, using the aggregate information contained in the annual reports and projects aligned with that NP. After evaluating the aggregated accomplishment summaries, the retrospective review panel assesses the value of the research that has actually been conducted as it compares to the accomplishments that had been projected in the NP Action Plan. The Panel also makes recommendations for future research priorities, which are then used by NP teams during the next NP Workshop and the development of the next 5-Year Action Plan. At this point, the current 5-year NP Action Plan is concluded, and the planning process for the next 5-year NP Action Plan begins.

BUDGET DEVELOPMENT

Establishing annual budgets

The annual fiscal budget year for ARS, as for all US government agencies, begins on October 1 of one calendar year and runs to September 30 of the following year. ARS budget planning reflects the Agency focus on assessing

research relevance, quality, and results. Every spring, NPLs, Area Directors, budget staff, and the Agency Administrator decide on budget requests to be made for the fiscal year that will begin in 18 months, including what research should be continued, what new research should be initiated, and what research, if any, should be terminated. In June, ARS submits its final recommendations for the ARS base budget (continued funding for ongoing research) and new funding for research initiatives to USDA. These recommendations are based on Administration priorities, progress included in the individual Annual Reports submitted for each project, and research needs identified through ongoing contacts with stakeholders and customers associated with each NP.

In September, USDA submits its consolidated Budget Request for all USDA agencies to the Executive Office of the President (Office of Management and Budget, or OMB) for further review and revision. In February, when the President's budget for the following fiscal year is submitted to Congress, it is accompanied by ARS Explanatory Notes that provide detailed justification for program changes; they also illustrate the link between individual Annual Reports and key agency wide research. The process of individual project accountability provides justification for its continued support and funding within ARS and USDA, and support from the President and Congress.

LONG-TERM AGENCY ACCOUNTABILITY

ARS 5-Year strategic plan

ARS is committed to its program of internal quality controls, and is also a full participant in the execution of external quality control processes mandated by the Federal government to address long-term performance accountability. ARS uses its 5-Year Strategic Plan as a key benchmark to assess Agency performance and progress. Using the Strategic Plan in this manner was facilitated in part by the passage of the 1993 Government Performance and Results Act (GPRA), which issued a comprehensive mandate for all Federal agencies to integrate strategic planning, budgeting, and performance measurement in order to better account for program results.

The ARS Strategic Plan outlines several broad Goals that clearly define what the Agency hopes to accomplish in the next 5-year cycle. In its 2003–2007 Plan, ARS derived its strategic goals directly from the USDA Strategic Plan, the REE mission area Strategic Plan, and legislation defining the purposes of federally supported agricultural research, extension, and education (Fig. 3). ARS customers, stakeholders, and partners were also consulted as part of the development process.

Each goal has several objectives that more precisely focus on furthering the mission and work of ARS, and performance measures and actionable strategies are developed for each objective. The performance measures describe specific measurable achievements that indicate progress toward reaching the broader

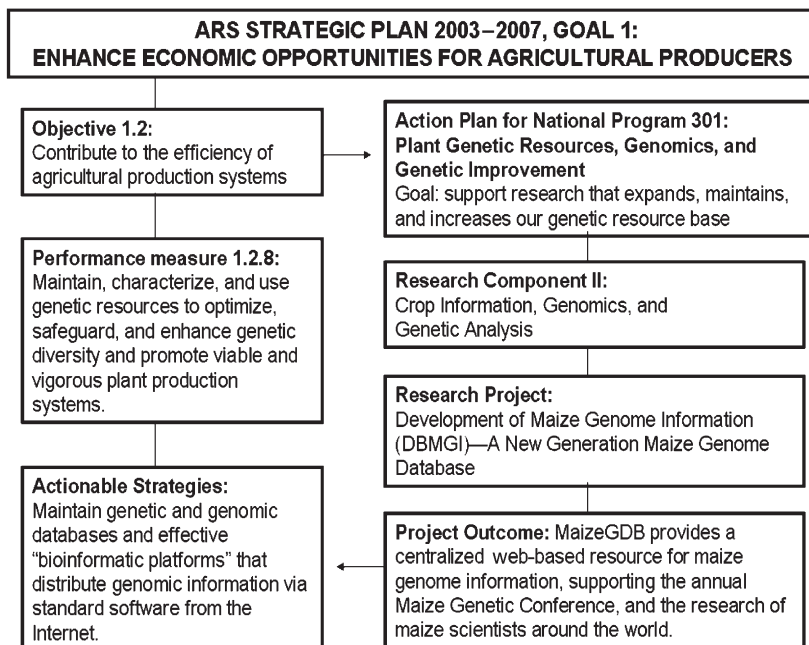

Figure 3. ARS strategic plan 2003–2007.

objectives and goals; actionable strategies spell out activities that need to be completed in order to mark progress in meeting the performance measures.

For example, evaluating the success of the Maize Genomics Database would consider how well it addressed the following factors:

- The first **Goal** in the 2003–2007 Strategic Plan is to enhance economic opportunities for agricultural producers.
- **Objective 1.2** under this **Goal** is to contribute to the efficiency of agricultural production systems.
- **Performance Measure 1.2.8** under **Objective 1.2** is to maintain, characterize, and use genetic resources to optimize, safeguard, and enhance genetic diversity and promote viable and vigorous plant production systems.
- An **Actionable Strategy** for this **Performance Measure** is to maintain genetic and genomic databases and effective “bioinformatic platforms” that distribute genomic information via standard software from the Internet.

The end result is a Plan that contains strategies, objectives, and tasks that are specifically designed to accomplish the broad Goals outlined in the 5-Year Strategic Plan. Using this framework ARS is able to verify that its work is ultimately directed toward achieving these long-term, desirable societal results. The strategic plan can be found at www.ars.usda.gov.

ANNUAL PERFORMANCE PLANS AND ANNUAL PERFORMANCE REPORTS

In response to directives developed for promoting government-wide accountability, ARS compiles Annual Performance Plans and Annual Performance Reports that review progress made in meeting goals established in the ARS 5-Year Strategic Plan. Annual Performance Plans identify specific performance indicators and projected outcomes that will indicate progress toward achieving set objectives and goals in the year to come if these indicators and outcomes are met. The Annual Performance Report reviews the mission and progress of the Agency as a whole in meeting the specific performance measures and indicators-of-progress in the previous year's Annual Performance Plan. The ARS Annual Performance Plan and Annual Performance Report are also available to the public at www.ars.usda.gov.

PROGRAM ASSESSMENT RATING TOOL

The President's Management Agenda (PMA), which was instituted in 2001, directed all Federal agencies to assemble a periodic assessment of their performance and results to strengthen the management of Federal programs and increase program accountability. In response, ARS began to assess Agency activity using the Program Assessment Rating Tool (PART). PART is a procedure developed and evaluated by the Office of Management and Budget that measures a program's effectiveness by evaluating four program components: purpose and design, strategic planning, management, and results/accountability. PART analysis provides ARS with an ongoing yardstick for measuring the overall, long-term effectiveness of its research programs. PART results can be found at www.expectmore.gov.

RESEARCH AND DEVELOPMENT INVESTMENT CRITERIA

Another element of the PMA is the Research and Development Investment Criteria (RDIC) of relevancy, performance, and quality. ARS conducts surveys of its activities using the RDIC, which are applied as follows:

- For relevance, NPLs assess whether ARS research is consistent with the Agency's mission and relevant to the needs of American agriculture, as identified by the Administration and ARS customers and stakeholders, and reflected in NP Action Plans.
- For performance, NPLs reviews the annual project reports submitted by each research unit. Beginning with FY 2004, these reports provide information on how well each research project did in achieving the milestones in its Project Plan, which is then used as an indicator of program performance.
- For quality, the Agency relies on data from the prospective ARS OSQR reviews of each research project at the beginning of its 5-year program cycle.

The information gained from PART and the RDIC review helps ARS identify low-performing and/or low-priority research. It is used in shaping future budget requests, program management decisions, and adjustments in the project's base funding.

All of the above assessments and reports keep the work of the Agency focused on achieving the larger goals established in the ARS 5-Year Strategic Plan. The reporting processes serve to strengthen ARS research programs and provide the basis for an accountability system that effectively measures the progress made in achieving established goals and outcomes.

EVALUATION OF PERSONAL SCIENTIFIC PERFORMANCE

ARS uses another highly regarded peer evaluation tool to ensure that scientists are appropriately recognized and compensated for their contributions toward achieving agency goals. This tool, the Research Position Evaluation System (RPES), is administered on a nationwide basis by the Research Position Evaluation Staff in the ARS Human Resources Division. RPES reviews ARS career research scientists (also called Category 1 positions; see box) to ensure classification accuracy, based on the "person-in-the-job" concept that gives research scientists the opportunity for advancement and open-ended promotion potential based on personal scientific accomplishments and professional stature. These professional classification reviews are regularly scheduled, but can be requested early.

With a few exceptions, research positions are reviewed by panels on a 3- to 5-year cycle to ensure professional classification remains appropriate given current job responsibilities.

Category 1 scientists include lead scientists and research leaders. Lead scientists have the responsibility to develop 5-year project research plans in consultation with other scientists, and modify plans in response to peer review recommendations. After projects have been approved, lead scientists coordinate the research activities of the other participating scientists, and make sure the project stays on its designated research track. In addition, professionals in this position manage personnel, funding, and facilities assigned to the project; prepare annual reports; and provide other technical information for internal and external dissemination.

Category 1 scientists

Category 1 scientists occupy permanent positions in which the highest level of work for a major portion of time involves personal research, or research and leadership, in theoretical and experimental investigations primarily of a basic or applied nature. This activity could include determining the nature, magnitude, and interrelationships of physical, biological, and psychological phenomena and processes; or creating or developing principles, criteria, methods, and a body of knowledge that could generally be used by others. RPES determines appropriate grade categories for Category 1 scientists, which in turn determines base salary levels.

Research leaders head management units and exercise direct authority over scientific and support personnel assigned to each unit. Research leaders are accountable for each project’s direction and scope, and ensure that research Project Plans meet approved standards for content and quality. They also monitor research teams to make sure Project Plans are being followed, hire staff, manage the unit’s budget, and oversee facilities and equipment in accordance with established ARS policies and procedures. Additional responsibilities include communicating technical information to internal staff and external parties, and verifying that the results of scientific research are properly interpreted and reported.

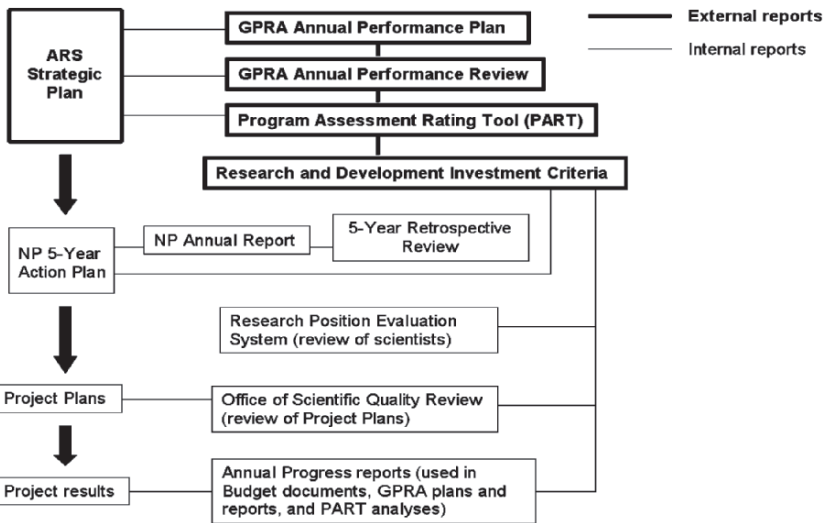

ARS ASSESSMENT PROGRAMS

Value of ARS research management

Measuring the economic benefits of scientific research is a difficult challenge for research managers and policymakers, especially in the short term. Several aspects of the research process contribute to this difficulty:

- The outcomes/impacts of research are difficult to identify and measure in advance.
- The value of knowledge gained is not always immediately recognized.
- Results are not always predictable.
- There is a high percentage of negative determinations or findings.
- Regardless of any data that may be generated from a research project, it remains impossible to measure the unknown.

Because of these factors, ARS uses a narrative approach in describing accomplishments in Annual Performance Reports, rather than attempting to

quantify research output using numeric metrics. Nevertheless, a USDA Economic Research Service survey indicates that most studies consistently find high rates of return (40–60%) for public investment in agricultural research and development. This high return rate is supported by carefully managing the process for selecting and implementing research projects, even if it is difficult to identify their immediate or long-term value in economic terms.

ARS research is not managed in a vacuum – it is constantly assessed for its relevance and its utility for agricultural producers and related industries that depend on agriculture to provide the raw materials for their own production processes. Transparent internal and external review processes keep ARS research on its defined path, and identify future research tracks that offer the greatest returns to American stakeholders and consumers. As the tools and results of ARS research evolve, so will the ways in which ARS establishes its short- and long-term research agendas, but the mandate will always remain—to use Federal resources in the most effective way for the greatest benefit of American citizens.

ACKNOWLEDGMENTS

The authors gratefully acknowledge the editorial contributions made by Ann Perry and David A. Rust, from the ARS NPS, throughout the development of this chapter.

REFERENCES

- Agricultural Research Service, www.ars.usda.gov
- ARS Plant Genetic Resources, Genomics and Genetic Improvement National Program (301). http://www.ars.usda.gov/research/programs/programs.htm?NP_CODE=301
- Agricultural Research Service Strategic Plan: 2003–2007. <http://www.ars.usda.gov/aboutus/docs.htm?docid=1766>
- Baker, G.L., Rasmussen, W.D., Wiser, V., and Porter, J.M., 1963. *Century of Service: The First 100 years of the United States Department of Agriculture*. US Government Printing Office, Washington, DC.
- Coulson, J.R., Vail, P.V., Dix, M.E., et al., (eds.) 2000. *One Hundred Ten years of Biological Control Research and Development in the United States Department of Agriculture, 1883–1993*. US Department of Agriculture, Agricultural Research Service, Washington, DC.
- Department of Agriculture Organic Act. <http://www.csrees.usda.gov/about/offices/legis/organic.html>
- Economic Research Service/USDA Briefing Room – Agricultural Research and Productivity: Questions and Answers. www.ers.usda.gov/Briefing/AgResearch/Questions/APRDQA6.HTM
- Forming Partnerships With the Agricultural Research Service, USDA-ARS Office of Technology Transfer Program Aid 1706, October 2005.
- National Science and Technology Council, July 2004. *Science for the 21st Century*. <http://www.ostp.gov/nstc/21stCentury/>
- Office of Management and Budget, Government Performance Results Act of 1993. <http://www.whitehouse.gov/omb/mgmt-gpra/gplaw2m.html>
- Office of Management and Budget, Program Assessment Rating Tool. <http://www.whitehouse.gov/omb/part/>

Rubenstein, K.D., and Heisey, P.W. 2005. Can technology transfer help public-sector researchers do more with less? The case of the USDA's Agricultural Research Service. *AgBioForum* (2&3):134–142.

www.expectmore.gov

www.whitehouse.gov/omb

CHAPTER 12

AGRICULTURAL RESEARCH MANAGEMENT IN US LAND-GRANT UNIVERSITIES

The state agricultural experiment station system

DONALD A. HOLT

Senior Associate Dean, Retired; Professor Emeritus of Crop Sciences; College of Agricultural, Consumer, and Environmental Sciences; University of Illinois

INTRODUCTION

Agricultural research management continues to evolve in US land-grant institutions. However, to some extent, it is still guided and constrained by historic legislation that specified the institutional structure within which publicly funded agricultural research is conducted in the United States. The legislation created the unique US institutions generally known as Land-Grant Universities, Agricultural Experiment Stations, and Cooperative Extension Service.

These institutions have been remarkably durable. For the most part, they were customer-oriented; served well-organized, supportive political constituencies; were quite decentralized; and adapted well to dramatic changes in agriculture. In fact, the institutions were architects of many of the changes.

However, it is difficult for the institutions to provide satisfactory service to an increasingly diverse clientele, increasingly specialized industry, increasingly complicated relationships with private firms and other agencies and organizations, and increasing competition for public funds.

ORGANIZATION OF AGRICULTURAL RESEARCH IN LAND-GRANT UNIVERSITIES

Agricultural Experiment Stations (AESs) are organizational units within land-grant universities. These units conduct and administer agricultural research programs. The officially designated state AESs are known collectively as the State Agricultural Experiment Station System (SAES).

Each state has only one land-grant university with comprehensive agricultural research and education programs. Each state has only one AES identified formally as part of the SAES. Some territories (e.g. Virgin Islands, Puerto Rico) have AESs also. Altogether there are 58 AESs in the United States and its territories.

It should be pointed out that many states have other universities and colleges besides land-grant universities that teach some agricultural courses, offer some agricultural degrees, and even perform some agricultural research. For example, in Illinois there are 25 institutions that teach agriculture at some level. A few have undergraduate and MS programs, and one offers a Ph.D. in agriculture. Three of these perform some research and share some state research funds with the Illinois Agricultural Experiment Station. Their programs are small, however, compared to those of the land-grant institution.

An AES (administrative unit) may include under its administrative umbrella several research stations and research farms (specific research locations and facilities). Because of the confusion caused by naming the collective agricultural research people, facilities, and programs of a university “the Agricultural Experiment Station”, some institutions have changed the name of their state AES to “Division of Agricultural Research” or some similar designation. In their relationships with the federal government, however, they are still SAESs.

HISTORY OF AES

Agricultural research management in the United States is guided to some extent by the history of public research institutions. Certain traditions and values were developed that still influence the management of agricultural research in these institutions.

Early agricultural research farms and stations

AESs were preceded historically by research farms and research stations. In 1669, the Lords Proprietors of Carolina commissioned a Joseph West to establish an agricultural research station on the Ashley River near old Charles Town in South Carolina (True, 1937). West was ordered to “find out the soil to which each species of plant was best adapted and the season of the year most favorable for planting”. The trials conducted by West and his Irish servants were probably the first systematic agricultural research conducted in North America.

Of research stations still in existence, the Rothamsted plots in England are considered the oldest. The Rothamsted research station was established in 1841 through an endowment provided by Sir John Lawes, owner of the Rothamsted estate and inventor of superphosphate, a manufactured fertilizer that is still in wide use.

In 1852, the first publicly supported “Landwirtschaftliche Versuchsstation” (agricultural research station) was established at Moeckern, Germany. By the mid-1870s, there were over 70 agricultural research stations in the German empire.

Active agricultural research programs in Germany inspired agriculturalists to establish agricultural research stations in the United States.

The first official state AES in the United States was established by a combination of private contribution and state appropriation in Connecticut in 1875 (Kerr, 1987). By the time the federal government began to provide support for agricultural research at state AESs, there were already 13 such stations in existence. These early experiment stations were focused primarily on agricultural chemistry, which in those days consisted mostly of analyzing soils, plants, and other agricultural materials.

The oldest continuously operated research plots in the western hemisphere are the Morrow Plots, now maintained as a National Historic Landmark on the campus of the University of Illinois. An experiment still underway on the Morrow Plots, a study of crop rotation and fertilization practices, was established in 1876, 12 years before the official establishment of the Illinois AES. The second oldest continuously operated research station in the United States is the Sanborn Field, established in 1888 and still maintained as an active research site on the campus of the University of Missouri in Columbia, Missouri.

Creation of the state agricultural experiment station system

The State Agricultural Experiment Station (SAES) system in the United States was created by the Hatch Act, federal legislation enacted in 1887. Earlier legislative efforts to create the system had failed. The successful effort was sponsored by William H. Hatch, representative from Missouri, who saw it as a way to make US agricultural industry more competitive in world markets for agricultural products.

Hatch proposed some clear practical objectives, that is, desired practical outcomes for federally funded agricultural research. In support of his proposed legislation, he wrote as follows:

It is becoming apparent from year to year that the United States have not the undisputed monopoly as the producers of cereals. For many years, owing to the newness and richness of our soils, we had a decided advantage over our competitors, much of which was due to advantages in transportation as well as ease and cheapness of production, and we held the markets of Southern Europe and Great Britain. Of late years Russia has become a large producer and exporter of wheat, while Australia and India are rapidly developing as wheat producing and exporting countries. The same is true of meat and other agricultural products. While this competition is sharp, and becoming more so, as transportation facilities are afforded our competitors, it would seem that every encouragement consistent with economy derived from science and experiment should be given in aid of this great industry. The object should be to increase production at a decreased cost and at the same time to preserve the fertility of our soils.

Hatch also recognized the site- and situation-specific nature of agricultural research results as indicated by this statement:

Experiments that are at all reliable can only be performed in the several localities and under their varying conditions.

The Hatch Act authorized the use of federal funds for the creation of state AESs within each land-grant university. Each year since then, the congress

appropriated money for AESs under the Hatch authorization. To implement the Hatch Act and receive federal funds, the boards of trustees of land-grant Universities had to commit to housing a state AES as part of the university and to match the federal contribution with state funds.

The land-grant universities themselves had been created earlier by the Morrill Act of 1862, signed into law by President Abraham Lincoln. The original concept of a Land-Grant University is attributed to Jonathan Baldwin Turner, an Illinois educator, who wrote extensively about the “industrial” university. In 1914, Congress added the cooperative extension function to land-grant universities by passage of the Smith-Lever Act.

The Morrill Act dedicated support “to the endowment, support, and maintenance of at least one college [in each state] where the leading object shall be – to teach such branches of learning as are related to agriculture and the mechanic arts”. The Hatch Act assigned to the land-grant institutions responsibility “to conduct original and other researches, investigations, and experiments bearing directly on and contributing to the establishment and maintenance of a permanent and effective agricultural industry of the United States, including researches basic to the problems of agriculture in its broadest aspects, and such investigations as have for their purpose the development and improvement of the rural home and rural life and the maximum contribution by agriculture to the welfare of the consumer, as may be deemed advisable, having due regard to the varying conditions and needs of the respective states”.

The original Smith-Lever Act (1914) added the important dimension of “diffusing among the people of the United States useful and practical information on subjects relating to agriculture and home economics and encouraging application of the same”.

Inclusion of the 1890s colleges

Enactment of the Second Morrill Act in 1890 provided land grants for the historically black colleges. It was not until 1967, however, that those colleges began to receive direct federal support for agricultural research. First by a grant in the Cooperative States Research Service (CSRS) Special Grants category and later through the Evans-Allen Act, the 1890s land-grant institutions were integrated into the federally supported agricultural research system. The Evans-Allen Act provides for an allocation equal to 15% of the Hatch appropriation, to be divided among the 16 1890s land-grant institutions using the Hatch formula. Research administrators of the 1890s colleges participate as full partners in national and regional planning and administration of the SAES.

Uniqueness of the land-grant universities

The Morrill, Hatch, Smith-Lever, and Evans-Allen Acts were remarkably visionary pieces of legislation. Universities focused on “agriculture and the mechanic arts” were indeed unique inventions. Teaching, research, and extension were not

new concepts, but putting these functions together in the same institutions was a unique approach to higher education, one that yielded tremendous positive benefits for the United States and the world. Often, individual scholars were asked to perform two or all three of these functions.

In each land-grant institution, the functions were directed by people who answered to the same dean, typically the dean of the college or school of agriculture. In many cases, the agriculture dean was also the director of research, teaching, and extension. This juxtaposition of functions and managerial responsibilities created not just a *research* system but also a *research and development* (R&D) system. This facilitated the transformation of new knowledge gained in research into practical technology employed by farmers and other AES clientele.

Scope of AES research

In general, the people employed by AESs conduct research on the basic things of life: the nurture of crops, animals, and families; and the provision of food, clothing, and shelter. AESs receive and allocate money and other resources from various sources to support agricultural research. Some of the funds are used to create and maintain a physical infrastructure for agricultural research. Administrators of these institutions also allocate funds to scientists and support staff that conduct the research.

AESs conduct research leading to improved productivity and efficiency of agricultural operations. They also conduct research leading to improvements in the quality of the products and processes associated with the industry of agriculture. In addition, the utilization of agricultural products and services by consumers is a subject of AES research. To appreciate fully the scope of AES research programs, one must understand some of the history of US agriculture.

Response of AESs to agricultural industrialization

Before 1860, farmers produced, processed, distributed, and retailed almost all agricultural products. Because almost all citizens were farmers, farmers consumed almost all agricultural products and services. Farmers also provided almost all of the necessary inputs and support services for agriculture. As US agriculture developed, agricultural tasks became increasingly specialized and a division of labor developed within US agriculture.

Now, US agriculture is a vast, geographically dispersed, decentralized, loosely organized conglomerate of producers, processors, distributors, and retailers of agricultural products and services. This conglomerate is served by an equally vast and complex infrastructure of private and public firms, institutions, organizations, and individuals.

US agriculture provides consumers with high-quality, safe, convenient, and affordable agricultural products and services. The products fall into categories of food, feed, fiber; and renewable sources of fuel and chemical feedstocks.

Agricultural services range from providing information on, and technology for, convenient packaging of meat products to providing information and management protocols for recreational activities in national forests.

The products and services of agriculture originate in managed ecosystems, but often go through many economic stages, at which intermediate products and services are produced, before reaching the final consumer. Producers play an important role in this system, but there are many other participants, as well.

Early AESs conducted research in support of farmers. Later, like agriculture as a whole, Agricultural Experiment Station programs became much more specialized, serving many newly emerging agricultural constituencies. In most land-grant universities, agricultural programs were originally organized into one department of agriculture. Later, these programs were subdivided into a number of agricultural disciplines, including agronomy, animal husbandry, agricultural engineering, and agricultural economics, among others.

Traditional agricultural disciplines continue to be subdivided into new specialties. For example, plant breeding might be divided into plant breeding and genetics. Genetics might be further subdivided into molecular genetics, classical genetics, population genetics, and physiological genetics. Now, molecular geneticists increasingly specialize in cell and tissue culture, gene identification, gene expression, gene transformation, and functional genomics.

AESs mount research programs in support of every constituency indicated in Figure 1. For example, some AESs conduct research on agricultural

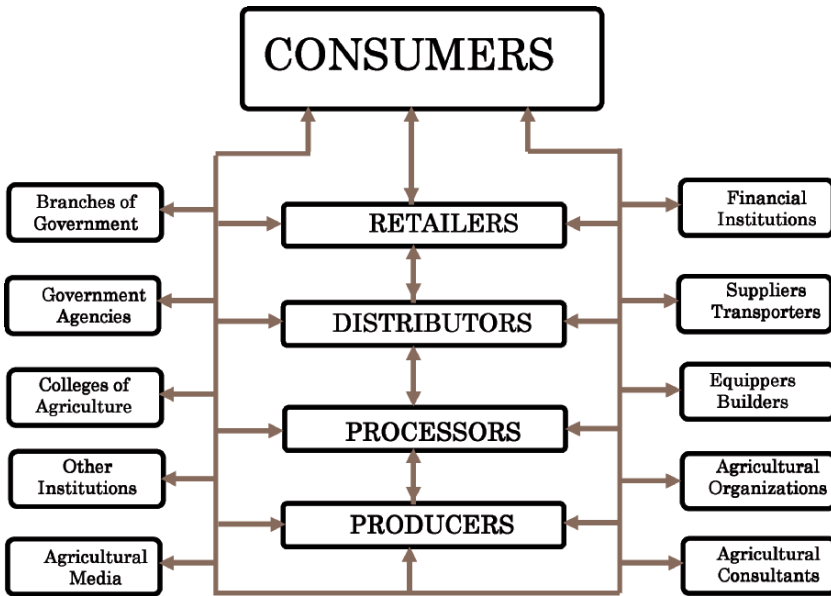

Figure 1. Diagram depicting the flow of products and information within the food and agriculture sector. (see Color Plate 7 following p. xvi.)

finance. They generate information that is useful to banks and other financial institutions. Some AESs have strong research programs in agricultural policy. These programs produce information used by various agriculture-related branches of government and government agencies.

Size and location of AESs

Good measures of the size and activities of AESs can be seen in the summaries of their expenditures. These expenditures are recorded and summarized in the Current Research Information System (CRIS, see CRIS website), a national system of accounting for AESs expenditures. Total annual expenditures for fiscal year 2005 ranged from US\$1,332,000 by the Virgin Islands Agricultural Experiment Station to US\$276,805,000 by the California Agricultural Experiment Station.

These expenditures included funds from all sources, including federal and state recurring allocations and federal, state, and private gifts, grants, and contracts. AESs also generate some resources from the sale of agricultural products (e.g. grain, livestock) and services (soil testing, plant disease diagnosis) produced and/or provided by the AES. The total SAES system expended over US\$3.3 billion for agricultural research in fiscal year 2005. About 40% of the total came from state appropriations earmarked for agricultural research and about 6% from federal formula funds.

AESs vary widely in the number of full-time equivalent (FTE) scientists employed in their operations. In 2005, that number varied from 4.3 FTE at the Virgin Islands AES to 459.2 FTEs at the New York AES. The total for the SAES system was estimated at 7,650 FTEs in 2005.

Location of AESs

As indicated earlier, AESs are located in every state and in some territories. Administrative headquarters are usually located at the state's land-grant institution, but the research facilities, including research farms, are usually distributed around the state or territory. The research farm locations are selected because they represent unique soil, climatic, and socioeconomic environments. Agricultural research facilities of AESs can be found in such diverse locations as river bottoms and high mountain meadows. They will be found in areas that are primarily crop-land or forest, in cold and hot regions, and under wet and dry conditions.

The diversity of locations of AESs helps to assure that agricultural technology and information is tailored to the unique needs and conditions of specific sites and situations. This is appropriate because the results of agricultural research, particularly adaptive research (see glossary), are characteristically site- and situation-specific. Taken collectively, the research farm system of the SAES is representative of every significant agricultural soil and climatic environment in the United States.

Organization of the SAES

Organization within the USDA

The Secretary of Agriculture is the chief executive officer of the United States Department of Agriculture (USDA Organization Chart). The research component of USDA is administered by an Assistant Secretary for Research, Education, and Economics. Currently, that person has general administrative responsibility for three subagencies, namely: the USDA-Cooperative States Research, Extension, and Education Service (CSREES), which is the extramural research arm of the science and education division; USDA Extension Service (ES), which is the extension arm, and USDA-Agricultural Research Service, the intramural research arm. The CSRS serves as the liaison between the state AESs and USDA.

Organization within NASULGC

AES administrators participate in the National Association of State Universities and Land-Grant Colleges (NASULGC). At its higher levels of organization, NASULGC includes a Board of Directors and several Commissions, which are made up of various lower groups. The Experiment Station Section functions within an Agricultural Assembly, which functions within the Commission on Food, Environment, and Renewable Resources (CFERR).

The executive group of the Experiment Station Section is known as the Agricultural Experiment Station Committee on Organization and Policy (ESCOP). There are parallel committees within NASULGC, designated ACOP, ECOP, and ICOP for the academic programs, extension, and international programs functions, respectively, of land-grant universities.

NASULGC provides an organizational mechanism through which AES administrators can develop program and budget recommendations for USDA. Those recommendations, backed by the prestige and influence of land-grant institutions, are usually heeded by USDA and incorporated into USDA recommendations for the Executive Branch (of the federal government) budget.

NASULGC's agriculture-related recommendations usually concern the federal formula funds and various federally funded competitive and special grant programs through which funds are channeled to the AESs. These recommendations are reviewed and modified by USDA and the Office of Management and Budget before they become part of the executive branch budget. The executive branch budget for federally funded agricultural research is ultimately presented as part of the President's budget recommendations to Congress.

NASULGC also makes its views about proposed programs and budgets known to members of Congress, either by direct communication or through the Council for Agricultural Research, Extension, and Teaching (CARET), which is made up of prominent agriculturalists from each of the states. These communications are not viewed as lobbying activities, but rather as educational activities solicited by members of Congress and congressional committees. NASULGC does employ lobbying firms, however, to enhance its communication with congress and the executive branch.

Organization within regions

The SAES are organized within each of four regions, namely the northcentral, northeastern, southern, and western regions. Regional organizational structure includes regional associations of Agricultural Experiment Station directors and regional research committees. Each director's association has an Executive Director, who coordinates regional activities and serves as a channel of communication with CSREES, other government agencies, and NASULGC.

Regional research committees are organized around specific research topics (NCRA website). They have designations such as: NC-1100, Rural Development, Work, and Poverty in the North Central Region; NC-1018, Impact of Climate and Soils on Crop Selection; NC-205, Ecology and Management of European Corn Borer and Other Lepidopteran Pests of Corn.

There are currently hundreds of such committees operating in the SAES system. The membership of a regional research committee is not restricted to scientists located within a specific region. For example, NC-140, entitled Rootstocks and Interstem Effects on Pome and Stone Fruit Trees, has representatives from over 30 states, Canada, and Mexico.

In an example of highly coordinated research, each member of NC-140 plants a replication of an experiment involving different combinations of rootstocks and interstems. In this manner, trees made up of these combinations can be observed and their yield, fruit quality, disease resistance, and other characteristics can be compared under virtually all the fruit-growing environments of North America. The information generated is of great practical and scientific significance.

Organization within states

As indicated earlier, AESs reside within land-grant institutions. They are ordinarily found within colleges of agriculture or colleges with agriculture in their titles, e.g. College of Agriculture and Life Sciences at the University of Wisconsin and the College of Agriculture and Natural Resources at Michigan State University. While there are some structural differences in colleges of agriculture, they are typically organized around higher education functions, namely research, teaching, extension, and, sometimes, international programs.

The chief executive officer of a college of agriculture may be called the Dean or Vice-President. In some institutions the Dean also serves as Director of each of the functions and so some deans are designated Director of the (state) AES. In the latter situation, the job of administering the everyday operations of an Agricultural Experiment Station is often delegated to an officer of the Dean's staff, who usually carries the title Associate Director.

Sometimes, each function has a separate Director and the Dean is responsible for coordinating the administration of the functions. In these situations the Director of the AES is a line officer in the SAES system, answering in his director role to the USDA-CSREES Administrator as well as to the Dean of his college. Directors may also carry the title of Associate Dean of the College of Agriculture, reflecting their status not only as line officers, but also as members of the Dean's staff. In their capacity as Associate Deans, Directors bear a

broader responsibility, helping the Dean coordinate the various functions within the college.

The administration of most AESs is decentralized, with most of the direct research responsibilities delegated to departments within colleges of agriculture. Common practice is to assign more than one function to each faculty member within a department. Such “split appointments” often entail a responsibility for research and teaching or research and extension. The three-way combination and the combination of teaching and extension are more rare. Split appointments foster the integration of research, teaching, and extension functions into a total R&D system.

Organization of AES programs and projects

Within AESs some funds are normally allocated directly to departments and further allocated to specific projects and programs. Some funds are retained at the level of the AES director and allocated to projects, programs, or needs that cut across two or more departments. The relative proportion of funds maintained for allocation at the AES Director’s level reflects the degree of central management of research activities. In fact, the level at which allocation decisions are made in the entire system determines the degree of central management. That degree decreases as authority to allocate funds to specific projects moves down in organizational hierarchy from congressional legislators through USDA, CSREES, regions, states, departments, and individual scientists.

The management at any level may be consensus-based, that is, policies may be developed through consensus-building processes. The level at which the consensus is sought determines the degree of central management, because it determines the level at which funds are allocated and policy implemented. Depending on the level at which consensus is sought, consensus management may be either centralized or decentralized.

Most research administrators would agree that certain research efforts, in which the results are very broadly applicable, could be effectively administered at the federal level. As the results become more site- and situation-specific, only decentralized management is effective. The results of adaptive research, for example, are usually site- and situation-specific. Therefore, adaptive research needs to be managed locally, often by such people as research scientists and research farm superintendents.

Financial support of the SAES

Costs associated with AESs

Since the subject matter of agricultural research is very diverse, this activity must be performed by people with diverse training, skills, and experience. Professorial and professional scientists of the AESs are trained in such diverse fields as plant pathology, animal physiology, microbiology, education,

sociology, and child psychology. They conduct research on microbes, plants, animals, humans, and communities.

AES scientists are supported by cadres of technicians and clerical people, some highly trained and experienced and possessing highly specialized skills. Graduate students play especially important roles in the conduct of agricultural research. Undergraduate students often are employed to help with laboratory and field operations. Of course, almost all of these people must be paid for their services.

To conduct their research, SAES scientists require laboratories, greenhouses, workrooms, research farms, pilot plants, computer centers, laboratory animal care facilities, and auditoriums. Their equipment ranges from electron microscopes, spectrophotometers, and supercomputers to no-till planters, tractors, sprayers, plows, disc harrows, and combines. For supplies, they require seed, gasoline, fertilizer, pesticides, animal pharmaceuticals, feed, and feed ingredients, laboratory chemicals, textiles, animals, laboratory glassware, lubricants, office supplies, tools, and countless other items. They require fleets of trucks, vans, automobiles, and other vehicles.

Agricultural research facilities are located on university campuses and on research farms scattered over the many soil, climatic, and socioeconomic environments of each state. These facilities must be operated and maintained. So AESs, like most other businesses, must pay electric, water, heating, and telephone bills.

Agricultural research programs require many support services, including procurement, accounting, waste removal, biosafety, administration, library services, publication capabilities, mail services, janitorial services, grounds maintenance, safety/security, and others. In various ways, AESs pay the costs of support services they provide for themselves as well as those they receive from their institutions.

Most AESs are multimillion dollar businesses. They face all the typical management problems of large-scale business operations plus a few more that are uniquely characteristic of public institutions.

Sources of funds to support SAES

All state AESs receive regularly recurring appropriations of state funds. The budget line for a state AES may be in a college of agriculture budget, university budget, higher education budget, or state budget. Thus, in some institutions, state money supporting agricultural research must move through several layers of administration.

In other AESs, the money comes more or less directly from the state budget. AES budget lines originating in state and college budgets represent the two extremes, with most institutions falling somewhere between. In states in which the Agricultural Experiment Station budget is actually reviewed by state legislative committees and voted upon as a separate budget line, the experiment stations seem to be somewhat better funded, dramatically so in some cases.

In addition to state funds, AESs receive federal formula funds authorized by the Hatch Act (1887). The formula used to determine each state's share of the appropriation is based on the relationship between the state's farm and rural population and the national farm and rural population. The formula causes each state's share to be roughly proportional to the magnitude of that state's agricultural enterprises relative to the total agriculture of the nation.

The formula is less than perfect. In 2005, formula allocations ranged from about \$940,000 for the Rhode Island and Alaska (the smallest and largest states) AESs to \$5.9 million for the North Carolina AES. California, with a far larger agricultural enterprise than any other state, did not receive the highest formula allocation.

For many AESs, over half the financial support comes in the form of gifts, grants, and contracts. These come from private individuals, businesses, foundations, and government agencies, both state and federal. Commodity groups and trade organizations contribute significantly to agricultural research in experiment stations.

Funds provided by any individual or group without restrictions on their use are classified as gifts. Monies provided by various granting agencies and private firms for research on specific topics are referred to as grants. Contract funds are similar to grant funds except that the expected outcome is defined more specifically. For example, universities enter into contracts with the private sector to test the efficacy and safety of specific prototype products, such as new pesticides.

Indirect cost recovery

Some granting agencies agree to pay the total indirect costs (utilities, administration, accounting, etc.) of projects, the levels of which are calculated by individual institutions and reviewed and approved by federal auditors. These often exceed 50% of the direct costs of projects. Some granting agencies insist on lower indirect cost rates, which are sometimes negotiated. To illustrate, the Illinois AES is able to recover indirect costs at the rate of 10% of direct costs from state agencies, resident USDA-ARS units, and some commodity groups. Ten percent is regarded as the state's "inside" indirect cost rate, a courtesy provided to other public agencies.

Organizations that refuse to pay indirect costs are actually asking the universities to pay those costs, which are real costs that must be recovered from somewhere. Universities sometimes agree to such arrangements if the amounts of money involved are relatively small, the restrictions on use of the funds are minimal, or the university stands to receive significant amounts of money in the form of royalties or other payments as a result of the funded research.

Indirect costs that are recovered in individual research projects are placed in an indirect cost fund or pool. University units can draw on this pool to purchase expendable supplies and services, such as gasoline and paper clips, in large quantities, taking advantage of bulk discounts. Were it not for this pool, the only legal way supplies, utilities, or services could be purchased for an

individual project is if an audit trail is established between project expenditures and each box of paper clips, gallon of gasoline, hour of clerical service, or other supplies or services used by the individual project. The bureaucracy required for such detailed accounting would greatly increase the cost of conducting research projects.

AESs obtain some funds through the sale of products and services generated in the research process. For example, AESs produce crops and livestock, some of which can be sold. Sales income may constitute 10% or more of AES budgets in some situations. Other sources of AES income include R&D fees (fees for research services rendered, usually to private firms) and royalties on the sale and/or licensing of intellectual property generated by AES research.

Trends in SAES funding

Originally SAESs were supported almost entirely by state and federal, regularly recurring funds, including formula funds. This situation has changed gradually to the point at which about a third of the total support for AESs comes from state funds, about 5% from federal formula funds, and the rest from gifts, grants, contracts, and sales of products and services.

In most cases, regularly recurring state funds are used to pay the salaries of relatively permanent people including professors, other professionals, and clerical and service people. These salaries might be considered the fixed costs of an AES. To an increasing extent, the variable costs of conducting AES operations are paid for with income from gifts, grants, and contracts.

Thus, in many ways, states provide the infrastructure, including permanent employees, buildings, facilities, and large durable items of capital equipment, for agricultural research in land-grant institutions. Granting agencies, contractors, and benevolent individuals provide the program support. To an increasing extent, those who provide the gifts, grants, and contracts are controlling the direction of research programs in the SAESs.

The increase in gifts, grants, and contracts as a proportion of total SAES support means that SAES people spend a greater proportion of their time competing for funds, since institutions must compete for gifts, grants, and contracts. The organizations and individuals providing gifts, grants, and contracts ordinarily award them to people they deem most likely to generate a high return on their investment. They are not necessarily selfishly motivated. Some wish their money to be used most effectively to benefit the general public or other groups.

Relationships of the SAES

Through their research and because their activities are closely integrated with those of academic and extension programs of land-grant universities, AESs have relationships with all other components of the industry of agriculture. No other entity within the industry has such elaborate relationships and such potential to create alliances that lead to improvement of the industry.

AESs and veterinary medicine

Colleges of veterinary medicine within land-grant universities receive some federal formula funds, i.e. formula funds for animal disease control, through the USDA. Also, AES directors ordinarily allocate some Hatch funds to veterinary medicine faculty for veterinary research essential to agricultural operations. Veterinary faculty often cooperate closely with agriculture faculty, especially animal scientists, in research and research animal health maintenance.

AESs and home economics

Research on the subject of home economics is conducted within AESs. This subject matter includes foods and nutrition, family and consumer economics, textiles and apparel, interior design, child development, and family ecology. In recent decades, most home economics colleges and departments have changed their names to such designations as human ecology or human resources and family studies.

Even when home economics units are organized as separate colleges in land-grant institutions, their research programs are usually administered at least in part by state Agricultural Experiment Stations. This is because federal formula funds identified for agricultural research were historically and traditionally allocated to home economics research, in accord with the stated goals of the Hatch Act with regard to the rural home. The use of funds for agricultural research to fund home economics research reflects the continuity that exists across the subject matter of agricultural research, from the planting of the seed to the manifestations of agricultural products and services in the health and welfare of consumers.

Originally, home economics research programs, like other agricultural research programs, were focused on the agricultural problems and opportunities of rural families, which constituted most of the population and were almost all farm families. Now most of the agricultural workforce and the vast majority of consumers of agricultural products and services live in urban areas, so home economics programs deal with both rural and urban concerns.

Relationships with the cooperative extension service

Since its origin in 1914, the Cooperative Extension Service has been the principal communication link among AESs, farmers, and other rural clients. Cooperative extension people work closely with agribusinesses, especially those who supply inputs, such as pesticides and fertilizers, to farmers. The common practice of appointing people to both research and extension responsibilities fostered a high degree of integration of research and extension activities.

As agriculture became more complex and specialized, however, AESs developed direct communications, through the medium of grant and contract research and educational activities, with some components of agriculture. Now processors, distributors, and retailers of agricultural products; consultants; large farmers; policy groups; seed firms; machinery and equipment suppliers; and some other groups often communicate directly with AES researchers, many of whom do not have extension appointments.

Originally the activities of AESs and cooperative extension services were very similar in subject matter and goals. In the last two decades, however, the scope of extension activities expanded into such areas of youth and families at risk and community development. While AESs mount some research in those areas, they have tended to remain focused on topics specifically related to the needs and opportunities of the industry of agriculture, broadly defined, and the consumers of agricultural products and services.

Relationships with farmers and agribusiness groups

In many ways, the AESs serve as the research arm of the business of farming. In this role, they test and compare the alternative practices and products associated with farming; identify the alternatives that are best suited for use in specific soil, climatic, and socioeconomic situations; and transfer information to farmers and agribusiness people that enables them to select the optimum combination of products and practices and integrate them into profitable farming systems.

Private firms conduct agricultural research of great benefit to the industry. Collectively, they invest more in R&D than AESs. In part this is because they must conduct both research (R) and development (D). For any given product development effort, the cost of D is generally 10 times that of R. Private sector research tends to focus on product development. Private firms, however, cannot be expected to provide totally objective information on competing products and services. Actually, a private firm must charge enough for products and services to pay for and profit from its R&D activities.

There are significant economies of scale and scope in agricultural research activities. Most farms are not big enough to mount their own complete R&D programs. It has proven more efficient and effective for some agricultural research to be a collective enterprise, conducted primarily within public institutions, especially the land-grant institutions. Since most of the benefits of agricultural research accrue to consumers of agricultural products and services, consumers need to bear some of the costs of agricultural research programs. Through a small portion of their taxes, US citizens support and benefit from agricultural research.

Through the medium of gifts, grants, and contracts, AESs work closely with agribusiness firms on specific R&D efforts. In recent years more and more of these relationships have involved proprietary considerations, e.g. patents, trade secrets, licenses, and copyrights. In many cases, ownership of new technology and rights to commercialize it must be established before research projects start. An attempt is made to divide some of the returns, namely royalties and profits, of commercializing new agricultural technology among those who contributed to developing the technology, more or less in proportion to their contribution.

AESs work primarily with the innovators and early adopters among the practitioners of agriculture at all levels. Other practitioners tend to get their information from the early adopters. According to 1960s research on the diffusion of technology (Rogers, 1962), about 15% of farmers are innovators and early adopters. I suspect that proportion may be somewhat higher now, but AESs still

work most closely with the leaders among producers and agribusiness people. This turns out to be the way to have maximum impact on the industry of agriculture.

Relationships with consumers of agricultural products and services

To the extent that AESs are a very important part of the nation's agricultural R&D capacity, the work of these institutions directly benefits the consumers of agricultural products and services. Numerous studies show that consumer benefits of publicly supported agricultural research are more than twice as great as producer benefits (Huffman and Evenson, 1993). In many ways, the consumers are the customers of the SAES. Farms, agribusinesses, and all other components of the industry of agriculture are partners with AESs in serving consumers' needs for agricultural products and services.

Relationships with public and private, nonprofit organizations

State AESs have close relationships with other AESs. Because of the regional organization of AESs, this relationship is especially close within regions. AESs work closely with other government agencies and subagencies, including the Environmental Protection Agency and Agency for International Development, as well as the US Forest Service, US Soil Conservation Service, and many other parts of the USDA. Many private, nonprofit agricultural organizations, such as commodity organizations, are sponsors and beneficiaries of AES work. Likewise, the AESs have benefited considerably from their association with these private organizations.

Relationships with other units of land-grant institutions

As an intrinsic part of a land-grant institution, an AES may allocate experiment station funds to several different administrative units within its university. Besides allocations to colleges of veterinary medicine and home economics, it is most common for AES funds to be allocated to colleges of engineering and biological sciences, since they deal with subject matter that is relevant to agriculture.

Contributions of the SAES

Scientists in state AESs, through their efforts in basic research, have contributed much to our understanding of the physical, chemical, biological, economic, and sociological nature of agricultural systems and materials. Besides these contributions of basic knowledge, through developmental research SAES have enabled development of an enormous number of new products and practices for agriculture.

These include such diverse contributions as new crop varieties, pesticides, fertilizers, tillage methods, animal breeds, animal products, foods, food processing techniques, machines and equipment, forest management techniques, renewable energy sources, building materials, and countless others. Through adaptive research SAES researchers help practitioners sort and select, among the vast

number of alternative products and practices, those that are best suited for the particular conditions faced by each practitioner.

One of the most important contributions of the SAES to agriculture are relationships among agricultural scientists in the SAES and the many client and customer groups they serve. Because of these relationships, the SAES are in good position to organize and participate in the alliances required to achieve specific practical agricultural objectives and thereby to achieve the mission of agriculture.

When a useful new item of agricultural technology or information generated by an AES is first introduced, the first people to employ the technology or information are the first to benefit from it (Figure 2). They produce and/or market more or higher quality products at the same or less cost and realize higher profits. When many people have adopted the new technology or information, supplies of the resulting product or service increase, prices come down, and benefits begin to accrue to the consumers. Those who are late to adopt the new approach may actually be disadvantaged by it, because they are placed in a less desirable competitive position. Thus, the primary beneficiaries of agricultural research are the early adopters and the consumers, with the consumers realizing most of the benefit.

Economists have attempted to calculate the producer and consumer benefits of public investment in agricultural research (Huffman and Evenson, 1993). The results of many studies suggest an average pretax return of 30–60% for major agricultural commodities, with an overall range from less than zero return (a loss) to over 200%. The consumer benefits of agricultural research are regressive, that is, lower income people realize much greater benefits in proportion to the amount they pay in taxes to support agricultural research.

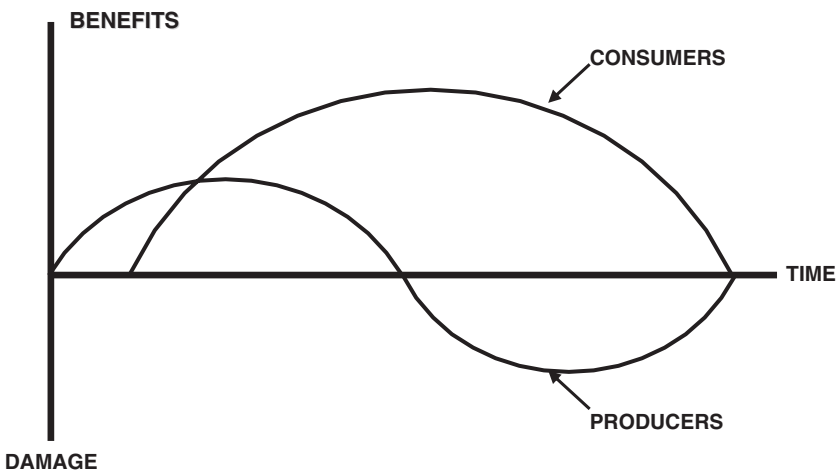

Figure 2. Diagram depicting the accrual of benefits and damage to consumers and producers with time from the introduction of a new item of technology generated by agricultural research.

The benefits become most apparent when one realizes that only about 20% of US resources (workers, purchasing power) are required to meet the effective demand for agricultural products and services, whereas in nations with less efficient agriculture, from 60–80% may be required. By continually helping the industry of agriculture improve the quality, safety, affordability, and convenience of its products and services and fostering change and competition within that industry, the AESs generate a constant stream of benefits for the general public and for industry participants.

Management challenges faced by AESs

The following discussion of management challenges focuses in part on the manner in which money is allocated to public sector agricultural research. Also emphasized is the level at which key management decisions are made and funds and other resources are allocated to subject matter areas. These levels include federal and state legislatures, government agencies, regional programs, land-grant university and campus administrations, and agriculture colleges, departments, and investigators. Providers of gifts, grants, and contracts for agricultural research also make important management decisions. Prevailing organizational paradigms of agricultural research profoundly affect management as well.

Formula funds versus competitive grants

In my opinion, the enduring viability and success of AESs is primarily attributable to the decentralized decision-making that characterized their management procedures and protocols for the first century of their existence. The high degree of decentralization, rare in federal- and state-funded organizations, was favored by formula allocation of federal and state (institutional) funds, which delivers resources to the frontline people (administrators, researchers, students, and staffs) in the AESs with relatively few restrictions on their use (Holt, 1990).

Information flowed both ways in these situations. New scientific advances flowed to the states via their AES scientists, who had national and international stature. Information about the site- and situation-specific needs of local and regional stakeholders flowed from the grassroots to the AESs via the Cooperative Extension Service as well as AES relationships with state agricultural constituencies. AES scientists and their local administrators, who came up through the academic ranks themselves, bridged the information gap between national and international scientific communities and those constituents facing local and regional problems and opportunities.

It was in these scientific communities that new technological possibilities were created. It was in the local scientist-stakeholder communities that the new possibilities were translated into advances that performed optimally in the diverse local and regional sites and situations within a state.

The decentralized approach enabled AESs to conduct research that was truly “mission-linked”, that is, organized around and directly linked to desired

practical outcomes in the state's diverse soil, climatic, and socioeconomic sites and situations. A more centralized approach might enable "mission-oriented" research. This deals with subject matter that might be relevant to agriculture, broadly defined, but not necessarily to the specific agricultural problems and opportunities of a state or region.

The decentralized system of AES research has come under attack, however, as a result of dramatic changes in federal research funding philosophy and policy over the last several decades. The era of "big science" in the United States started in the late 1950s and 1960s with the rapid growth of research funded through competitive federal grants offered by the National Science Foundation, National Institutes of Health, Department of Defense, and, to a lesser extent, other agencies. The US Department of Agriculture soon fell far behind as a sponsor of extramural research.

The Department of Agriculture was criticized for not allocating research funds on a competitive basis. They were also criticized for supporting "applied research". People in the Office of Management and Budget (OMB), who prepare the executive branch budget, and other groups admonished the land-grant institutions that "government should support basic research and the private sector will conduct the applied research". In a variation of this theme, it is asserted that the federal government should only support basic research and the states should support the applied research specific to their interests and concerns.

There is a perception that formula funds, which are not allocated competitively at the federal level, are in the same category as "earmarks", usually referred to as "pork barrel" politics. They are not regarded as addressing issues of national importance. Critics argue that formula funds are allocated on some other basis than the recipient scientists' capabilities. Almost every year since the 1980s the federal budget proposal from the executive branch included sharp reductions in or elimination of formula funding. Congress, representing the interests of the states, always restored the formula funds, but resistance continues to grow.

The outcome of federal budget deliberations with regard to formula funds becomes more uncertain every year. The executive branch budget proposal for fiscal year 2008 includes "redirection" of some of the formula funds toward nationally competitive programs. There are USDA competitive grants offered under the National Agricultural Research Initiative (NRI), which now totals over US\$180 million, about the same as the total of the formula funds. NRI grants are available primarily for basic research relevant to agriculture, broadly defined.

In total, federal (USDA) funding of agricultural research is miniscule compared to programs of other federal agencies, e.g. NSF (about US\$5.6 billion in 2006; NSF website) and NIH (nearly US\$28 billion in 2006; NIH website). This situation exists in spite of numerous studies showing the exceptionally high rate of return on public investment in agricultural research (Huffman and Evenson, 1993). Of course, some research funded by nonagricultural agencies is relevant to agriculture, just as agricultural research contributes greatly to biomedical research and other fields of investigation.

Because of the decentralization, the key strategic management decisions involved in AES research were traditionally made by agricultural college and department-level administrators and research faculty. The key decisions in each case, and the ones with the most far-reaching consequences, are the selection of the subject matter areas to be addressed by new tenure-track faculty.

Such decisions shape the research program for decades into the future. For example, should we hire a genomics specialist to replace the plant breeder who just retired? Of course, it is important to create positions in which scientists can be successful. This means positions in which they can obtain adequate funds and other resources for their research programs.

Ideally, hiring decisions are influenced by input from organized agricultural constituencies in the state. These groups are likely to be keenly aware of problems and opportunities affecting their members. Also, through their financial support, they often are able to help recruit outstanding people to occupy key research positions.

Increasingly, hiring decisions are influenced by the current areas of emphasis of the major federal granting agencies. To illustrate, when considering the strategy for staffing a new genetics building at the University of Illinois, an administrator recommended that the building be populated with people who can compete successfully for NIH grants. NIH is by far the largest source of federal funds for research. Of course, those funds are focused on biomedical research, only some of which is relevant to agriculture.

Because of the changes in federal funding philosophy, it is increasingly difficult for an AES to be “internationally preeminent and locally relevant,” a goal established for the University of Illinois College of Agricultural, Consumer, and Environmental Sciences by Dean Robert Easter. Were it not for the need to address important agricultural research needs within individual states, AESs could deploy their formula and state recurring funds to attract and retain outstanding scientists, regardless of discipline.

These people, provided excellent facilities and salaries, are increasingly expected to compete for the funds required to support their research programs. This is the easiest way to manage public sector research and the way to achieve international preeminence. Ordinarily, this approach stretches the recurring funds over the largest (although not necessarily the most relevant) research program. It would be reasonable to ask, however, if AESs evolve into basic research operations only indirectly relevant to state agricultural problems and opportunities, why have state AESs?

In general, the most successful individual scientists in modern AESs assemble large, well-financed and well-equipped teams of postdoctoral students, graduate students, other professionals, technicians, and laborers. Few such programs could be financed in AESs with only formula or state recurring funds. Such large individual programs can only be financed by a combination of institutional funds (formula and state recurring) and large federal or, rarely, private grants, and almost always more than one such grant.

Strategy and tactics

Important management decisions address both the strategic question (what is the most important thing to do?) and tactical question (what is the best way to do it?). Within an AES, the strategic question is answered in a broad sense when decisions are made to hire people who will work in certain disciplines. More specific strategic decisions are made when a scientist selects the subject matter of individual projects.

The need to obtain funds through competitive grants strongly influences the strategic decisions. Researchers are selected because they work in a certain discipline or subdiscipline, one in which ample grant monies are available. Researchers make strategic decisions based on their ability to compete for grants available for research in various disciplines.

Increasingly, important strategic decisions are strongly influenced by granting-agency people. They decide what the portfolio of federal research investments will look like in terms of disciplines within which grants will be solicited and the relative amounts of funds to be allocated among the disciplines and subdisciplines.

Agency people, using various techniques for soliciting the input of scientists, seek a consensus in the scientific community across and within disciplines as to how appropriated grant funds should be allocated. Unfortunately but inevitably, consensus-based decision-making is sometimes influenced by prevailing paradigms and fads and often arrives at the lowest common denominator.

Tactical decisions are strongly influenced by the people who review and approve competitive grants for funds. Only those proposals seen by the review panels as employing the correct methods and materials are funded. The usual condition is that there are far more applicants than available funds. This discourages review panels from funding high-risk research enterprises, such as those using new and unproven approaches. In the best situations, research investment portfolios are balanced in terms of subject matter and risk.

Huffman and Just (2000) list institutional problems arising from the potential shifting of formula funds to competitive grants as major sources of research funding. These include (reworded in some cases): (1) scientist time is diverted from directly productive (to the employing state) activities to proposal writing, reporting, reviewing, and related administrative activities; (2) costs are compensated according to a proposed budget rather than actual research output; (3) quality proposals rather than quality research output is rewarded, in spite of the fact that the two are imperfectly correlated; (4) compensation is determined before the grant is deployed thus eliminating quality of output as incentive; (5) the riskiness of research is imposed unduly on scientists, encouraging them to be risk-averse; (6) the highest quality scientists may tend to focus on proposal writing and other aspects of grant solicitation while less experienced and capable people conduct the actual research, and (7) peer-review committees sometimes misjudge project potential and/or impose narrow views on research approaches, thus reducing the sampling diversity.

These problems seem to me to be inherent in situations in which individual investigator competitive grant programs are the principle source of extramural

research support. They are not a result of mismanaging the competitive grant programs. The unresolved question is whether the advantages of the competitive grant system of allocating research funds outweigh the disadvantages.

While an increase in funds for federally administered competitive grants for agricultural research is certainly desirable, the elimination of formula funds is not desirable. Econometric studies indicate that an increase in federal competitive grant funding at the expense of federal formula funding would lower the productivity of public agricultural research (Huffman and Evenson, 2003). That change would also reduce the positive impact of the research on “total factor productivity” of a state’s agriculture. Such changes move the SAES system away from its decentralized management of the past. They make the AESs less responsive to local problems and constituencies.

The agricultural problems and opportunities of specific sites and situations and local constituencies may be state and local from a producer standpoint but they are national and even international from the standpoint of processors, distributors, retailers, and consumers and most of the supporting infrastructure. Thus, agricultural research conducted in a specific region or locale often has great “spillover” benefits for consumers and some producers outside the region or locale.

Formula allocations to states are a mechanism by which a state recovers a portion of the cost of creating the spillover benefits through state-supported research. Without this compensation, state AESs will be consistently underfunded. The nation will forego a very high rate of return on that potential investment.

A nation’s agricultural producers compete with those of other nations for global commodity markets. Nations gain competitive advantage by enabling their producers to be the early adopters of new and improved new technology. Historically, AESs helped US producers capture large shares of those markets by enabling them to be low-cost producers, just as William Hatch foresaw when he authored the Hatch Act, which created the SAES.

In an age of information technology and multinational agribusinesses, the results of basic research and the new technologies generated by developmental research rapidly become available to all competing nations. The nation that mounts the most effective adaptive research program enables its producers to select the technologies best suited to the specific soil, climatic, and socio-economic situations in which they operate (Holt, 1987). Through this selection, they gain competitive advantage. Because the results of site- and situation-specific research are not very relevant to the sites and situations of other nations, that research is the key to gaining competitive advantage.

Organizational challenges facing public agricultural research managers

AESs conduct and cooperate in basic, developmental, and adaptive research. Ideally, these functions are integrated with technology transfer mechanisms, including the Cooperative Extension Service.

The research and technology transfer functions can be organized in a linear, sequential mode (Fig. 3, upper diagram). In this linear paradigm, basic research is conducted first. The philosophy of the linear paradigm is that if a suitable

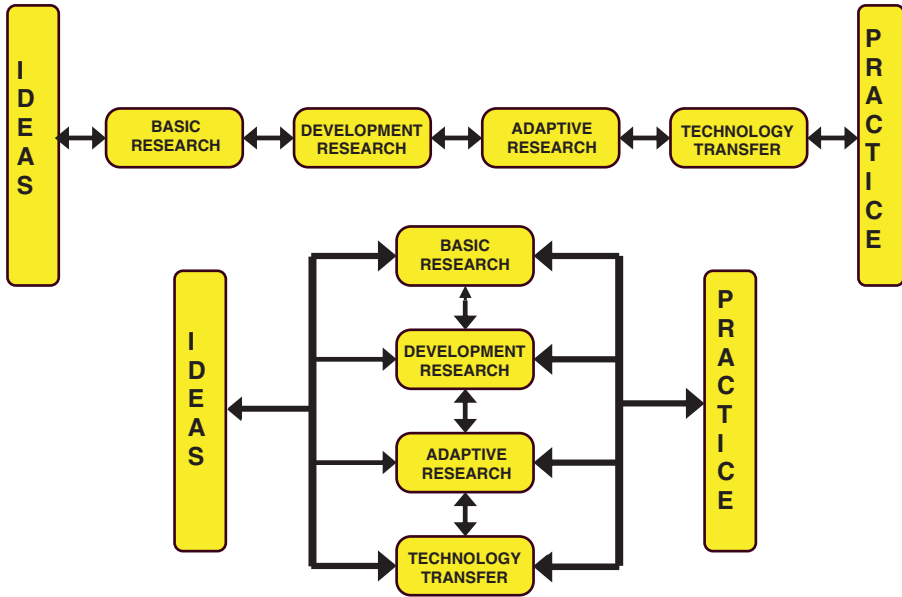

Figure 3. Two organizational paradigms of agricultural research. Upper diagram depicts linear organization of research and development (R&D) functions linking ideas to commercial practise. Lower diagram depicts parallel organization of R& D functions. (see Color Plate 8 following p. xvii.)

knowledge base is created, institutions, agencies, and private firms with capacity for developmental and adaptive research and technology transfer will function sequentially to translate the basic knowledge into practical technology and information for use by agricultural practitioners.

In an alternative organizational approach, the functions are conducted simultaneously instead of sequentially (Fig. 3, lower diagram). In this parallel model, desired practical outcomes are identified and described as specific, quantifiable, practical goals. Teams of research and technology transfer people are organized to accomplish the goals. Literature on private sector R&D describes the parallel approach as functionally integrated R&D or “concurrent engineering.”

The parallel organizational paradigm is favored in private sector R&D and is gaining favor with such agricultural research sponsors as commodity groups. This is because it is seen as more closely focused on desired outcomes. It is more likely to shorten the development process, thus reducing R&D costs and increasing return on investment. This is accomplished through more timely introduction of new and improved products and services.

A further level of complexity is added as a project progresses and the level of activity within functions shifts from early-stage to later-stage R&D. At times project progress is evaluated, the composition of teams changes, and managers make go no-go decisions. This is illustrated diagrammatically in Figure 4, representing the concept of the stage-gate system of product development (Cooper, 1990).

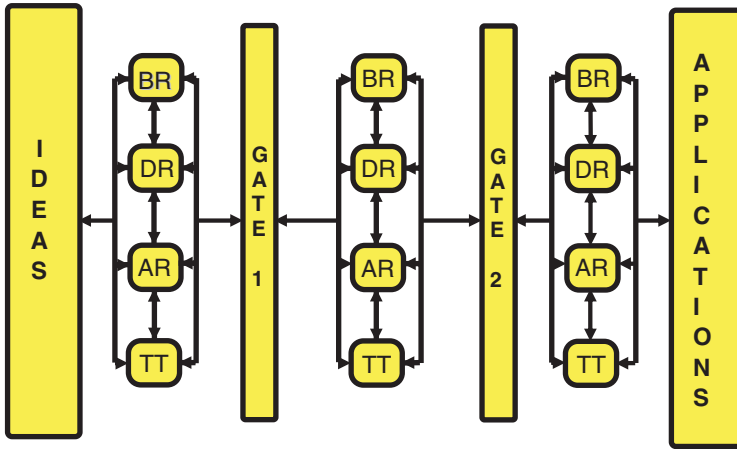

Figure 4. Diagram depicting the stage - gate paradigm of agricultural research organization. (see Color Plate 9 following p. xvii.)

Early experience with commodity checkoff programs illustrates a practical dimension of organizational paradigms. Money collected from farmers through assessments on the sale of commodity crops was used by commodity groups to sponsor competitive research grant programs within their states. At first, they solicited proposals in categories of scientific disciplines, such as genetics, plant pathology, or animal sciences, just as federal grants are usually solicited.

After a period of years, farmer board members began to ask, when are we going to see improved varieties or other new practical technology coming out of the research we sponsored? Both farmers and researchers were perplexed, because good research was conducted and reported and yet the sponsors were not getting what they expected. The problem was that they had not asked for what they expected. They asked for good research and they received good research.

The situation improved when commodity groups were asked to solicit proposals in categories of desired practical outcomes. Among other revelations, it became evident that a single investigator, no matter how sophisticated his/her research program, rarely produces new practical technology. New technology is almost always the result of team effort, involving people with diverse knowledge and skills.

To be relevant to the agriculture of their states and the nation, AES scientists must be able to function within teams. This will be necessary especially when the teams are comprised of people from different institutions, organizations, and firms. Experience shows that organizations such as universities with high individual performance standards and less well-defined organizational performance standards are less effective in mounting or participating in team efforts (Katzenbach and Smith, 1993). Private firms, on the other hand, which have

high and readily measurable organizational performance standards, are more successful in mounting team efforts.

Ideally, when R&D is fully integrated, it is integrated not only over R&D functions, but also over scientific disciplines and links in value chains. In a project integrated over disciplines, the physical, chemical, biological, economic, social, and political dimensions of a scientific/technological problem or opportunity are explored simultaneously. In a project integrated over the links or economic stages in value chains, which include R&D, production, processing, distribution, retailing, and utilization, all these dimensions are investigated simultaneously.

Economic stages in converging and diverging value chains, such as those providing inputs and those generating by-products, may also need research support as part of a parallel research effort. For example, improved ethanol production technology might never be adopted unless there are related improvements in by-product processing and utilization technology.

For each specific practical goal there is an appropriate combination of functions, disciplines, and value-added tasks that should be conducted by the R&D team. To achieve full integration it is probably necessary to have people on R&D teams representing those who will implement the potential new technology and information, those who will supply it, and those who will consume the resulting products or services.

Of course, such a high degree of integration may not be practical in many cases, in part because the transaction costs (costs of communicating and coordinating within complex projects) may be too high to justify the additional effort. In reality, not all tasks in an R&D effort can be conducted simultaneously. Nevertheless, private sector R&D managers have advanced the art and science of research management beyond that practiced in universities.

R&D managers identify all the tasks required in an R&D effort to produce the desired outcome. They identify those tasks that must be conducted simultaneously. These determine the "critical path" and specify the minimum time to accomplish the objective. Other tasks can be carried out simultaneously within the project timeframe. Information technology, including sophisticated project management software, is used to organize projects. Sometimes, these projects involve thousands of tasks and achieve extraordinary levels of communication and coordination among project participants.

AESs, because of their unique positions within land-grant institutions and their close integration with academic and extension programs, were originally organized ideally to expedite and foster functionally integrated R&D. These unique institutions brought together people with expertise in the various functions and disciplines. This, coupled with the close relationships with their traditional clientele, mostly farmers, helped link and integrate all the activities leading from ideas for new technology to practical application on the farm. A land-grant university was almost self-sufficient in its service to its farmer clientele.

As the agricultural infrastructure became more complex, however, it became more difficult to coordinate and integrate all the activities required to translate

ideas to practical technology in use in agriculture. The value chains became more complex, involving more stages and participants. The disciplines divided into subdisciplines and sub-subdisciplines. Now, no single institution can afford or is inclined to employ people with all the necessary and useful disciplinary expertise.

For reasons described earlier, federal funding programs and universities tend to focus on basic research, expecting the private sector to perform the developmental and adaptive research and technology transfer. This complicates the task of organizing functionally integrated R&D efforts involving AES scientists. Further complications arose as universities realized the need and opportunity to protect and manage intellectual property generated by university scientists. This was especially difficult for agriculture colleges within land-grant institutions. Their tradition and culture has been free exchange of knowledge and technology. Until the last two decades, intellectual property generated in AESs was placed in the public domain without restrictions on its use.

To remain relevant, AES researchers need to participate in functionally integrated R&D projects conducted by private firms. They can make important contributions at almost every stage of team efforts required to accomplish objectives in complex vertically coordinated markets. Even now, if you look back down those large-scale, increasingly sophisticated, and highly organized supply chains, you will see land-grant university colleges of agriculture and their AESs, as well as other colleges and universities.

These institutions supply: diverse human capital; some biophysical capital, such as germplasm; a really vast scientific infrastructure; knowledge capital; prototype technology; formal education and in-service training; a superb communication infrastructure; and effective institutional structures. Among their less tangible contributions is a vast network of worldwide personal and institutional relationships that foster and enable unusual levels of communication, cooperation, coordination, and integration.

Firms, agencies, institutions, organizations, and even individuals at all levels in these complex value chains sponsor AES research likely to create possibilities for new or improved technology and information. Actually, these groups out-source the research they want to accomplish. AESs become suppliers, facing increasing competition from other suppliers of research-based technology and information.

In these team efforts, AES scientists may only be involved in the basic and early stage developmental research, or they may also be involved in adaptive research, e.g. variety trials and nutritional studies, in which the new technology is tested and compared with competing products and services. This research also allows researchers to identify the soil, climatic, and socioeconomic regions or sites in which the new products perform well or do not perform well. Most AESs routinely conduct product testing, especially with such products as pesticides, insecticides, fertilizers, feed additives, etc. under material testing agreements with private firms.

The complexity of relationships involved in functionally integrated R&D is analogous in some respects to the complexity faced by modern manufacturing firms. Increasingly, manufacturing firms purchase components and services from specialized suppliers (outsourcing) and merely assemble the final product. For the manufacturing process to work, each component must fit in the final product and perform its unique role effectively. The components must arrive on time, arrive in appropriate quantities, and meet exact specifications required for the manufacturing process, so that it is unnecessary for the manufacturer to maintain large inventories of parts or products (just-in-time manufacturing).

In the outsourcing situation, each of the suppliers has marketing, design, manufacturing, accounting, and business administration functions, among others, that must be closely coordinated with those of its customer, the manufacturer. In this situation, the high degree of interdependency among manufacturers and suppliers mandates an extraordinarily high level of communication, cooperation, and coordination.

The industrialization that characterizes modern agriculture increasingly involves contract production, outsourcing, just-in-time manufacturing/production, and other mechanisms by which markets are vertically coordinated. If AESs can effectively integrate their research operations with other participants in complex agricultural value chains, they will continue to play a unique and vital role and make extremely valuable contributions to the success of the US food and agriculture sector, global agricultural operations, and world health and welfare. A more detailed description of how AESs can and, hopefully, will play a role in agriculture of the 21st century can be found in Holt and Sonka (1994).

REFERENCES

- Cooper, R.G. 1990. Stage-gate systems: a new tool for managing new products. *Business Horizons* May-June.
- Holt, D.A. 1987. A competitive R&D strategy for agriculture. *Science* 237:1401-1402.
- Holt, D.A. 1990. Recapturing the vision: the case for formula funds. Proc. 1989 *Annu. Meet. Agric. Res. Inst.* Agricultural Research Institute, Bethesda, MD.
- Holt, D.A. and Sonka, S.T. 1994. Virtual agriculture: developing and transferring agricultural technology in the 21st century. *Proc. 2nd Internat. Conf. Site-Specific Manag. Agric. Syst.* American Society of Agronomy, Madison, Wisconsin.
- Huffman, W.E. and Evenson, R.E. 1993. *Science for Agriculture: A Long-Term Perspective*. Iowa State University Press, Ames, IA.
- Huffman, W.E., and Evenson, R.E. 2003. New econometric evidence on agricultural total factor productivity determinants: impact of funding sources. Working paper 03029, Iowa State University Department of Economics, Ames, IA.
- Huffman, W.E., and Just, R.E. 2000. Setting efficient incentives for agricultural research: lessons from principal-agent theory. *American Journal of Agricultural Economy* 82:4:828-841.
- Katzenbach, J.R., and Smith, D.K. 1993. *The Wisdom of Teams: Creating the High-Performance Organization*. Harvard Business School Press, Boston, MA.
- Kerr, N.A. 1987. *The Legacy: a Centennial History of the State Agricultural Experiment Stations*. Missouri Agricultural Experiment Station, Columbia, Missouri.
- Rogers, E.M. 1962. *Diffusion of Innovations*. Free Press of Glencoe, New York.

True, A.C. 1937. *A History of Agricultural Experimentation and Research in the United States, 1607–1925, Including a History of the United States Department of Agriculture*. USDA Misc. Publ. No. 251, United States Government Printing Office, Washington, DC.

WEBSITES CITED

USDA Organization Chart, <http://www.usda.gov/ling/content/org_chart_enlarged.jpg>, viewed 2/12/1907

NIH Website, <http://www.nih.gov/about/>, viewed 3/07/07.

NSF Website, http://www.nsf.gov/about/congress/109/highlights/cu06_0112.jsp, viewed 3/07/07.

NCRA Research Portfolio Website, <http://www.wisc.edu/ncralregional.htm>, viewed 3/0

CHAPTER 13

USDA-CSREES NATIONAL RESEARCH INITIATIVE: SUPPORT FOR AGRICULTURAL RESEARCH

The competitive grants program in the United States

CHAVONDA JACOBS-YOUNG, MARK A. MIRANDO,
AND ANNA PALMISANO

*Competitive Programs Unit, Cooperative State Research, Education, and Extension Service, US
Department of Agriculture, Washington, DC 20250-2241, USA*

INTRODUCTION

The United States Department of Agriculture (USDA) supports extramural agriculturally related science through the Cooperative State Research, Education, and Extension Service (CSREES). The mission of CSREES is “to advance knowledge for agriculture, the environment, human health and well-being, and communities.” All CSREES programs support one or more of six strategic goals:

1. Enhance International Competitiveness of American Agriculture
2. Enhance the Competitiveness and Sustainability of Rural and Farm Economies
3. Support Increased Economic Opportunities and Improved Quality of Life in Rural America
4. Enhance Protection and Safety of the Nation’s Agriculture and Food Supply
5. Improve the Nation’s Nutrition and Health
6. Protect and Enhance the Nation’s Natural Resource Base and Environment

While CSREES supports extramural research, education, and extension through several different funding mechanisms, herein we will focus on competitive grants.

The National Research Initiative (NRI) Competitive Grants Program is the USDA’s major competitive grants program and is administered by CSREES. The NRI provides funding for work on a wide range of research and integrated research, education, and extension activities. Topics range from animal agriculture, to plant science, microbiology, natural resources, and the environment, human nutrition and food safety, economics, and rural sociology. Rigorous peer review, a hallmark of the NRI, facilitates the identification of grant proposals with the greatest merit and contributes to the outstanding scientific reputation of the program. NRI funding is provided to US institutions, organizations, and

individuals through several different types of grant award mechanisms. This chapter will describe: (1) a brief history of competitive grant funding within the USDA; (2) program scope and structure; (3) priority setting and the development of proposal solicitations; (4) the peer review process; and (5) post-award management of funded projects.

HISTORY OF COMPETITIVE RESEARCH AT THE UNITED STATES DEPARTMENT OF AGRICULTURE

Before 1978, competitive grant funding for agricultural research was not available from the US Federal Government. Federal funding support for agricultural research occurred primarily through noncompetitive funding of the USDA in-house research agency, the Agricultural Research Service, and through funding provided to individual state agricultural experiment stations on a formula basis under the provisions of the Hatch Experiment Station Act of 1887.

Establishment of Competitive Research Grants Programs resulted from a National Research Council report criticizing the quality of agricultural research in the United States and recommending funding of research on a peer-reviewed competitively awarded basis (National Research Council, 1972). This program was authorized by the US Congress in the Food and Agriculture Act of 1977 (Public Law 95–113) for 5 years beginning at a funding level of US\$25 million in the first year and increasing gradually to US\$50 million in the fifth year (Lipman-Blumen et al., 1989). For its initial year, Congress appropriated only US\$15 million of funding for the new competitive grants program. The USDA's Competitive Research Grants Programs was modeled after the highly regarded competitive research grants programs of the National Science Foundation and National Institutes of Health.

In 1990, a report by the US Congress' Office of Technology Assessment recommended funding for a new competitive research grants program in agriculture, food, and the environment (US Congress, 1990). Later that year, the National Research Initiative (NRI) Competitive Grants Program was authorized by Congress in the Food and Agriculture Act at a funding level of US\$500 million; however, the NRI has never been appropriated the maximal level of funding authorized. In fiscal year 2006, the NRI reached approximately US\$181 million (Figure 1).

PROGRAM SCOPE

Currently, the NRI consists of 26 programs organized into four program clusters: Agricultural Biosecurity and Genomics; Agricultural Production and Value Added Processing; Nutrition, Food Safety, and Quality; and Agroecosystems and Rural Prosperity (Table 1). The NRI supports both basic and applied research approaches, as well as integrated research, education, and extension activities (USDA, 2006).

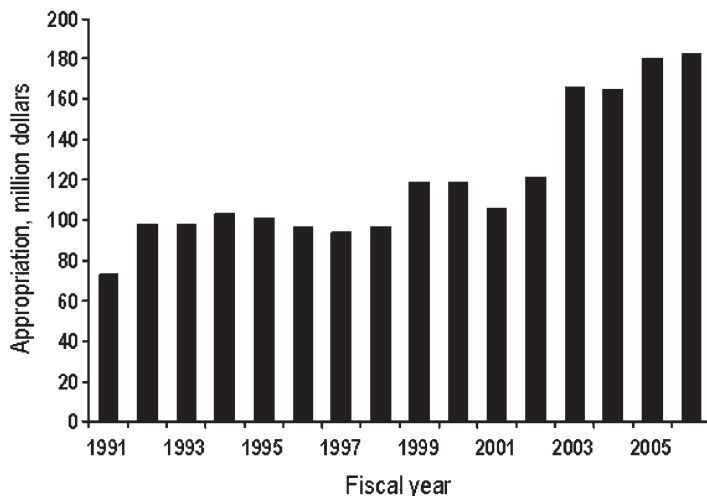

Figure 1. Total Congressional appropriations to the National Research Initiative Competitive Grants program for fiscal years 1991 through 2006.

Agricultural Genomics and Biosecurity. The agricultural genomics and biosecurity program cluster addresses new and reemerging pathogens or pests of major economic significance in the United States that threaten both industry viability and consumer access to safe and affordable food. Crop, forestry, and animal improvements are supported within this program cluster. The programs offered in this cluster contribute to an effective security program for animals and plants that will allow the United States to respond effectively to the intentional or accidental entry of a foreign pathogen, pest, or other biological threat to the US food supply. Knowledge derived from programs in this cluster also helps to improve agricultural efficiency and sustainability, lower production costs, and aid the discovery of new and improved food and forest products for consumers, as well as development of alternatives to pesticides and antibiotics to control disease outbreaks.

Agricultural Production and Value-Added Processing. Agricultural production and marketing play a crucial role in the success and growth of the Nation's economy. The Agricultural Production and Value-Added Processing cluster addresses current and future challenges to food, feed and fiber production, postharvest processing, and competitiveness of US agriculture in domestic and international markets. Projects in this cluster also support the science-based knowledge and technology development needed to identify new and improved uses for agricultural and forestry biomass in the production of biofuels and bio-based industrial products. Basic research supported by the agricultural production and value-added processing program cluster is

Table 1. National Research Initiative program clusters

Program cluster	Programs
Agricultural Genomics and Biosecurity	Plant Biosecurity Animal Genome Animal Protection and Biosecurity Microbial Genomics Arthropod and Nematode Biology and Management Microbial Biology Plant Genome
Agricultural Production and Value-Added Processing	Animal Reproduction Animal Growth and Nutrient Utilization Plant Biology: Foundation for Agricultural and Forest Plant Production and Improvement Agricultural Markets and Trade Biobased Products and Bioenergy Production Research Nanoscale Science and Engineering for Agriculture and Food Systems
Nutrition, Food Safety, and Quality	Bioactive Food Components for Optimal Health Human Nutrition and Obesity Food Safety and Epidemiology Improving Food Quality and Value
Agroecosystems and Rural Prosperity	Managed Ecosystems Soil Processes Water and Watersheds Global Change Initiatives Air Quality Biology of Weedy and Invasive Species in Agroecosystems Rural Development Agricultural Prosperity for Small and Medium-Sized Farms

essential to forming the foundation of scientific knowledge needed to use the increasing amounts of genomic data, tools, and resources for food, feed, and fiber production. Projects supported in this cluster incorporate cutting-edge technologies and tools, such as nanotechnology, genomics, proteomics, and metabolic engineering to ensure that agricultural production in the United States remains competitive, innovative, and sustainable.

Programs in the agricultural production and value-added processing cluster range from fundamental research on plant and animal biology to applied research on product development, improvement, and agricultural markets and trade, thus linking basic research to application, policy, and practice. Education and outreach activities supported by integrated project grants in these programs enable transfer of knowledge from researchers to producers, consumers, industry, and other stakeholders.

Nutrition, Food Safety, and Quality. Nutrition, obesity prevention, and food safety are of paramount importance to the producer, processor, distributor, and consumer. Projects supported in this cluster improve the understanding of behavioral and environmental factors that influence obesity and that lead to development and evaluation of effective interventions for obesity prevention. It also contributes to knowledge of the requirements and bioavailability of food components and factors, including food processing technologies and interrelationships among dietary components, that impact optimal human nutrition or food quality. Work supported by this program cluster increases understanding of disease-causing pathogens and toxins, the risk factors that influence foodborne organisms and food safety, and the risk factors that lead to the development and implementation of mitigation or control strategies. Results from this program cluster also are used to update dietary recommendations, formulate national nutrition and food safety policies, and stimulate the development of new products by the food industry.

Agroecosystems and Rural Prosperity. Agroecosystems are inherently complex, being composed of agricultural, natural, and social systems. The fundamental concept behind the projects supported in this cluster is the application of ecological, economic, and sociological principles to agricultural and community systems. The concept of agroecosystems is applied to agriculture, rangeland, forested or community systems at a range of spatial scales at the level of the field, family, farm enterprise, landscape, watershed, institutional, and community. The Agroecosystems and Rural Prosperity program cluster supports projects that address the design or function of productive agriculture and rural communities that sustain yields and rural prosperity while minimizing the negative environmental impacts of agricultural practices and technologies on surrounding natural ecosystems.

PROGRAM STRUCTURE

The NRI provides funding through several different types of grant mechanisms. These include standard research grants, research conference grants, standard strengthening research grants, new investigator awards, postdoctoral fellowships, seed grants, career enhancement awards, and equipment grants. More recently, the NRI has developed programs for integrated research, education, and extension project grants and coordinated agricultural project (CAP) awards.

Standard research grants typically range from US\$300,000 to US\$1,000,000 for 2–4 years of support, with funding limits established for each individual program. Standard research grants are independent investigator awards made to individual investigators or multidisciplinary teams of investigators. Research conference grants bring together scientists to identify research, education or extension needs, update information, or advance an area of science as integral parts of scientific efforts. Standard strengthening research grants, new investigator awards, postdoctoral fellowships, seed grants, and career enhancement awards are types of Agricultural Research Enhancement Awards (AREA). The AREA program targets specific groups of individual investigators and/or institutions to enhance their research capabilities and assist in building their competitive research programs.

In fiscal year 2003, Congress authorized expenditures of up to 20% of funds appropriated to the NRI to support projects that integrate at least two of the three functions of research, education, and extension. For integrated projects, “education” is defined as formal classroom instruction, laboratory instruction, and practicum experience in the food and agricultural sciences and other related matters, such as faculty development, student recruitment and services, curriculum development, instructional materials and equipment, and innovative teaching methodologies. “Extension” is defined as a series of educational activities with identified learning objectives that deliver science-based knowledge to people outside of the traditional classroom (e.g. agricultural producers), enabling them to make better-informed practical decisions.

The NRI also has the ability to target specific gaps and make rapid progress on emerging issues through CAP awards. CAP awards are special types of large multi-investigator, multi-institutional integrated project grants that promote collaboration, coordination, and communication in high priority areas. The awards are up to \$5 million for 2–4 years of support, depending on the individual program area. CAP awards have been used successfully to address emerging topics, such as avian influenza, translating rice genomics to application, and epidemiologic food safety research.

For the NRI, the average grant duration is approximately three years. Grants are regulated by terms and conditions, which are established by the CSREES and issued to the performing institution or organization prior to the start of the award. These terms and conditions provide details on reporting requirements, policies, and regulations that apply to the grant award. Funding for each NRI grant award typically is provided as a single payment of total funds awarded for the entire award period and is made at the beginning of the award.

Eligibility for receipt of NRI grants is restricted to institutions, organizations, and individuals residing within the United States. Entities eligible to apply for and receive NRI grants include State Agricultural Experiment Stations, US colleges and universities, other US research institutions and organizations, state laboratories and agencies, Federal agencies, national laboratories, private organizations or corporations, and individuals. Eligibility for NRI postdoctoral

fellowships is limited to US citizens. For integrated research, education and extension grants, eligibility includes State Agricultural Experiment Stations, US colleges and universities, research foundations maintained by colleges or universities, private research organizations with established and demonstrated capacities to perform research or technology transfer, Federal research agencies, and national laboratories. Proposals from scientists at non-US organizations are not eligible for consideration of support.

SETTING PROGRAM PRIORITIES AND DEVELOPING A REQUEST FOR APPLICATIONS (RFA)

The NRI sets priorities based on five criteria: (1) mission relevance; (2) potential impact on science, agriculture, and society; (3) scientific opportunity and enabling technologies; (4) linkages to other programs; and (5) stakeholder input. Mission relevance, criterion 1, means that all programs must be aligned with the six CSREES strategic goals, as previously discussed. Criterion 2 addresses the broader impact and significance of our program investments to scientific knowledge, to agriculture in its broadest sense, and to our society. Criterion 3 helps to ensure that our programs are taking advantage of recent scientific breakthroughs, as well as new enabling technologies, such as genomic sequencing technologies or new bioinformatics tools.

Interagency collaboration (criterion 4) is key to leveraging the limited funds appropriated to the NRI to achieve greater impact in areas of high priority. These collaborations also minimize duplication of effort among funding agencies by minimizing overlap and enable the identification of critical knowledge gaps. Program staff play essential leadership roles in many interagency working groups under the President's National Science and Technology Council. Examples of NRI programs involved in interagency collaboration include the Microbial Genome Sequencing Program (with the National Science Foundation [NSF]), the Maize Genome Program with NSF and the Department of Energy [DOE]), Microbial Observatories (with NSF), Plant Feedstock Genomics for Bioenergy (with DOE), Metabolic Engineering (with NSF, National Institutes of Health, DOE, National Aeronautics and Space Administration [NASA], and other agencies), and the Climate Change Science Plan (with DOE, NASA, NSF, and other agencies).

NRI program staff seeks external input from a wide range of stakeholders (criterion 5) to establish program priorities. Stakeholders include scientific societies; the National Academy of Science; USDA's National Research, Education, Extension and Economics Advisory Board; producers, processors, and industry groups; the university system; non-governmental organizations; other federal science and regulatory agencies; international organizations, and others. The NRI program staff are responsible for integrating all of the information gathered, identifying the highest priority topics, and developing a Request for Applications that is commensurate with the funding available (USDA, 2006).

NRI program staff also seeks guidance from the CSREES Science Advisor and the Education and Extension Advisor who are appointed by the agency to assist in program strategic planning and to facilitate communication among a broad array of stakeholders in the scientific and academic communities. Both the Science Advisor and the Education and Extension Advisor are highly respected professionals recruited from the academic community to serve temporary (i.e. 2-year) appointments as part-time employees of the agency. An example of how stakeholder input for the NRI Animal Reproduction Program was gathered and utilized in formulating focused funding priorities can be found in Mirando and Hamernik (2006).

THE PEER REVIEW PROCESS

The NRI request for applications. The review process for proposals submitted to the NRI begins with the publication of the Request for Applications (RFA). The RFA is published on the agency website and available through an array of individual funding opportunity web pages. The RFA includes all of the pertinent information for the current funding cycle, including changes in legislative mandates, award types, eligibility requirements, evaluation criteria, submission instructions, program goals and funding priorities, and proposal submission deadlines. The NRI also conducts two grantsmanship workshops annually to educate applicants on the individual funding opportunities available in the program. Applicants review the RFA and frequently contact the program staff to discuss applicability of a topic to the program goals and suitability for prospective submission as a proposal. Applicants are encouraged to submit only those proposals that are responsive to the funding priorities outlined in the RFA. Acceptable proposals are evaluated using the peer review process, whereas proposals that are not responsive to the RFA are returned to the applicant without further review.

Selection of a panel manager. Each program leader selects a panel manager to assist with administration of the program. The panel manager is an individual that is an active and established scientist possessing broad-based knowledge within the program area. The professional stature of the panel manager within their respective scientific community brings additional visibility and recognition to the program. The panel manager is hired as a part-time temporary (i.e. 1–2 years) USDA employee. Duties of the panel manager include assisting the program leader in selecting panel members and ad hoc reviewers, assigning proposals to reviewers, chairing the panel meeting, and assisting the program leader with making final funding decisions.

Selection of reviewers. The program leader and panel manager study the proposals carefully and assign them for review to panel reviewers and, when additional expertise is needed, to ad hoc reviewers. Each proposal is assigned to 3–4 panelists for review. Each panelist typically is assigned 15–20 proposals, for which they provide written reviews, and also provide oral evaluation of the proposals during the review panel meeting. It is critical to assemble a diverse

panel of individuals who are active in research, education, and/or extension, and whose composition is reflective of the applicants submitting to the program. The goal is to create a balanced panel with the necessary expertise to cover the breadth of the proposals submitted, while also maintaining diversity in geographical location, institution size and type, professional rank, gender, and ethnicity. Programs also strive to have continuity on the panel from previous years by inviting at least 30% of the panelists to return for a subsequent year.

Confidentiality and conflicts of interest. Confidentiality is critical to ensuring the integrity of the peer review process. Proposal content and identity of applicants, reviewer identity and discussion comments made during the review panel meeting are all to remain confidential. This issue is emphasized repeatedly from the time that invitations to serve on the panel are extended through to completion of the panel meeting. Additionally, written reviews and evaluations of each proposal are shared only with the respective applicant. The obvious exception to the latter is that the panel manager, panel reviewers, and program staff are permitted access to the other written reviews immediately before and during the panel meeting.

During the review process, special care is taken to avoid conflicts of interest. Individuals involved in the review process may not participate in any aspect of the proposal evaluation if they have: (1) served as an advisor or advisee to the applicant; (2) collaborated or served as a coauthor with the applicant during the past 3 years; (3) are currently affiliated with the institution of the applicant or coapplicant, or (4) stand to materially profit from an award decision. These rules apply to the program staff, as well as to the panel manager, panelists, and ad hoc reviewers.

The review panel meeting. Reviewers prepare written reviews using the evaluation criteria, published in the RFA and available on the CSREES website, to assess the strengths and weaknesses of each proposal. Proposals are evaluated for scientific merit, qualifications of project personnel, and adequacy of facilities, and relevance to program priorities and importance of the topic. During the panel meeting, the panelists discuss the proposal and arrive at a consensus ranking of the proposal. Ranking categories used within the NRI are “outstanding”, “high priority”, “medium priority”, “low priority” and “do not fund”. Only proposals ranked in the first three categories may be considered for funding, whereas those ranked in the latter two categories are ineligible to receive an award. Realistically, however, most NRI programs are unable to fund all of the proposals ranked as high priority and several programs are unable to support all proposal ranked in the outstanding category.

Following the evaluation and initial ranking of each proposal, a “panel summary” statement is written by a panel member that details the panel’s assessment of the strengths and weaknesses of the proposal and provides a synthesis statement, which includes areas for improvement and provides comments that either encourages or discourages resubmission of a revised application. On the final day of panel meeting, the panelists reassess the initial rankings

of the proposals and rerank proposals, as needed, to ensure that the proposals have been categorized accurately. After the completion of the panel, the program leader and panel manager review the top proposals to arrive at final award funding decisions. Following the review panel meeting and the program's arrival at funding decisions, applicants receive verbatim copies of the written reviews of their proposal (with reviewer name removed), the panel summary statement, and information on the relative ranking of their proposal. This information is sent to the applicant electronically through e-mail correspondence.

POST-AWARD MANAGEMENT

Impact of Competitive Research and Integrated Activities. The NRI strives to support high quality, innovative, and hypothesis-driven research and integrated activities that are of high scientific merit. Assessing the quality and impact of projects funded by the NRI is critical to the success of the program. The impact of funded projects is assessed through post-award management, which includes annual progress reports and awardee meetings. Currently within the NRI, submission of a progress report is required annually near the anniversary of each project's start date. In the progress report, project directors must provide a comparison of actual accomplishments with the goals established for the reporting period, including a statement of impact and information on deliverables (e.g. publications, patents, development of new products or technologies). Within 90 days after the award's expiration date, awardees also must submit a final report that describes progress made during the entire period of the project, including a disclosure of any inventions or publications not reported previously. These reports are reviewed by scientific staff and posted on the CSREES website to keep the public informed of supported projects and the impacts on agriculture.

Project Directors of NRI awards are required to attend an annual awardee meeting during the duration of the award. The awardee meeting provides project directors an opportunity to provide an update on the progress of the supported project, as well as share information with other awardees. The meetings often lead to collaborations and networking among participants. Information shared at the meetings can be used by National Program Leaders to assist in program planning and to identify success stories for communicating program impact.

Site visits are also important to post-award management. Program leaders and other scientific staff visit research sites and keep in touch with researchers on a routine basis to monitor project progress. Acknowledgment of support from the NRI is also required to appear in any publications and presentations that are based substantially upon or developed under the award.

NRI Accomplishments. CSREES publishes information throughout its website on results and impacts of completed and ongoing research and integrated activities, including the NRI annual report (<http://www.csrees.usda.gov/funding/nri/nri.html>). Significant accomplishments of NRI-funded projects are many and varied. Achievements include:

- As part of an international effort, the NRI contributed support to the successful completion of the sequence of the rice genome. In addition to facilitating the application of genomic information to improve rice cultivation, completion of the rice genomic sequence will serve as a model system that is now greatly accelerating the understanding of all cereal grains.
- Biofuels research resulted in the development of recombinant yeast capable of increasing the ethanol production from wheat straw by 40%.
- Fundamental research on pests and diseases has led to the development of a preventative treatment for screwworm, an important insect pest of livestock. It is estimated that this development will save US agriculture over US\$1 billion annually by preventing losses in production and overcoming international trade barriers related to this pest.
- NRI supported research examining the spatial and temporal dispersion of fungal spores is currently being utilized to inform growers of the danger of soybean rust in their region, to prevent the spread of the disease, to reduce the use of expensive fungicides, and to produce healthier crops in a cleaner environment.
- Fundamental research in animal reproduction has elucidated the function of a key protein system, the ubiquitin-proteasome system, in sperm and its role in livestock fertility. The research has resulted in a patented procedure for rapidly and inexpensively assessing the fertility of genetically superior males.
- Scientific knowledge has been generated to engineer corn to improve its nutrient and economic value. The findings could enhance our ability to address world hunger by providing corn with more protein and oil to those in the world who depend on grain as their primary source of nutrients.

The NRI advances fundamental science in support of agriculture and provides opportunities to build on these discoveries. Funding agricultural research and integrated activities utilizing a competitive funding mechanism provides many advantages, including: (1) the ability to respond quickly to new and emerging issues by issuing a request for applications to solicit the best and most innovative approaches; (2) the ability to bring together world class scientists from all disciplines to address a topic area; (3) the ability to leverage investments made by other federal agencies in specialized capabilities; (4) the ability to translate research results into tangible benefits and outcomes, and (5) the ability to advance training and education through the participation of degree granting institutions for long-term national benefits. The NRI is internationally recognized and has served as a model for the development of agriculturally related competitive programs throughout the world.

REFERENCES

- Lipman-Blumen J., DeRyke S., and Carlson M. 1989. Metaphor for change: The USDA competitive grants program, FY78-FY84. LBS International, Ltd., Claremont, CA.
- Mirando M.A., and Hamernik D.L. 2006. Funding priorities in animal reproduction at the United States Department of Agriculture's Cooperative State Research, Education, and Extension Service. *Biology of Reproduction* 74:459-462.

- National Research Council. 1972. Report on the Committee on Research Advisory to the US Department of Agriculture. National Technical Information Services, Springfield, VA.
- US Congress. 1990. Agricultural research and technology transfer policies for the 1990s. A special report of OTA's assessment on emerging technology: issues for the 1990s. Office of Technology Assessment, Congress of the United States, Washington, DC.
- United States Department of Agriculture. 2006. Cooperative State Research, Education, and Extension Service; National Research Initiative Competitive Grants Program FY 2007 Request for Applications RFA. http://www.csrees.usda.gov/funding/rfas/pdfs/07_nri.pdf. Accessed May 31, 2007.

CHAPTER 14

AGRICULTURAL RESEARCH GOVERNANCE AND MANAGEMENT IN NIGERIA

N.O. ADEDIPE^{1,2,3}

Department of Crop Protection and Environmental Biology, University of Ibadan, Ibadan, Nigeria

HISTORICAL

First generation (regional) research institutes 1893–1955

In Nigeria, agricultural research, in its ramifications of plans, strategies, programmes, governance, and management, dates back to over one century. The profile is characterized by three periods: the first generation of *regional research departments* (1893–1955); the *inter territorial (West African) research institutes* (1944–1954); and the *second generation of (national) research institutes* (1975–2006). These have culminated in 17 agricultural research institutes, which respectively deal with specific, narrow range of commodities and are predominantly crop-based, with only five dealing with livestock, animal health, and fisheries, respectively, and are described below.

As detailed by Okigbo (1994), the rudiments of agricultural research commenced with a Botanical Research Station at Ikoyi, Lagos, in 1912 through the establishment of a Southern Nigeria Department of Agriculture at Moor Plantation, Ibadan, and a Northern Nigeria Department of Agriculture in Samaru, Zaria. The two were amalgamated in 1922 with mandate-oriented agricultural research and extension policies. In 1951, the Southern component bifurcated into the Eastern and Western research stations at Umudike and at Ibadan respectively, consequent on the creation of three geopolitical Regions for the governance of Nigeria. The Federal Institute of Industrial Research was also established in Oshodi, Lagos. This was followed, in 1955, by the establishment of the Federal Department of

¹ Currently, Visiting Professor (Capacity Building), National Universities Commission, Abuja, Nigeria.

² Former Project Manager, World Bank supported National Agricultural Research Project, Federal Ministry of Agriculture and Rural Development, Abuja, Nigeria.

³ Foundation Vice-Chancellor, University of Agriculture, Abeokuta, Nigeria.

Agricultural Research, with headquarters in Moor Plantation, Ibadan. This signalled the adoption of four main research stations, the one being Federal (Central) to cater for an apical overview, and the three others being Regional to take care of the major economic and food crops of each Region.

INTER-TERRITORIAL (WEST AFRICAN) RESEARCH INSTITUTES 1944–1954.

During 1944–1954, the Colonial Government, in consonance with its policy for British West Africa, established: the West African Cocoa Research Institute in Tafo, Ghana, 1944, and later at Ibadan, Nigeria; the West African Institute for Trypanosomiasis Research, Kaduna, 1947; the West African Institute for Rice Research at Rokupr, Sierra Leone, 1954; the West African Institute for Oil Palm Research, Benin, 1954; and the Storage Products Research Institute, Ibadan, 1954.

Second Generation (Commodity) National Research Institutes, 1975–2006 are as follows:

- *National Cereals Research Institute, Ibadan, now at Badeggi*
- *National Root Crops Research Institute, Umudike*
- *National Institute for Horticultural Research, Ibadan*
- *Cocoa Research Institute of Nigeria, Ibadan*
- *Rubber Research Institute of Nigeria, Benin-City*
- *Forestry Research Institute of Nigeria, Ibadan*
- *National Veterinary Research Institute, Vom, Jos*
- *National Animal Production Research Institute, Shika, Zaria*
- *National Institute for Trypanosomiasis Research, Kaduna*
- *Nigerian Institute for Oil Palm Research, Benin*
- *Lake Chad Research Institute, Maiduguri.*
- *National Agricultural Extension and Research Liaison Services, Samaru, Zaria*
- *Institute for Agricultural Research, Samaru, Zaria.*
- *Institute of Agricultural Research and Training, Ibadan*
- *National Institute for Freshwater Fisheries, New Bussa.*
- *Nigerian Institute for Oceanographic and Marine Research, Lagos.*

From the above, it is clear that Nigerian Agricultural Research, changing with prevailing circumstances, has been around for over 100 years. The extent to which the institutes have delivered research dividends for agricultural efficiency towards national economic growth and development is, however, debatable, and will be discussed later.

DETERMINATION OF RESEARCH PRIORITIES

The national agricultural research institutes: unstable governance structure

In 1969, the institutes were coordinated by the National Council for Science and Technology (NCST), followed by the Agricultural Research Council of Nigeria (ARCN) in 1971. As presented above, the number of research

institutes stabilized at 16 in 1975. Till then, but inconsistently, the institutes had a governmental overseer-agency, the names and compositions of which were unstable. In 1977, the institutes (each with its own governing board) were coordinated by the National Science and Technology Development Agency (NSTDA) which was replaced by the Federal Ministry of Science and Technology (FMST) in 1980, succeeded by the Federal Ministry of Education, Science, and Technology in 1984, back to the Federal Ministry of Science and Technology in 1985 (Adedipe, 1994; Idachaba, 1987). Since then, the coordination of the institutes has been under the Federal Ministry of Agriculture and Water Resources, now Federal Ministry of Agriculture and Rural Development, clustered under the Department of Agricultural Sciences. During these periods of instability, however, research priorities were mainly at the level of each institute, with informal inputs from some University Faculties of Agriculture and some State Ministries of Agriculture. The typical institute management, headed by its Director, and within its research mandate, utilized programme leaders (Heads of Divisions) to formulate projects, involving the Extension Officer and a few selected prominent farmers. Some elements of monitoring and evaluation were periodically injected depending on the life cycle of the project.

Current status of the national agricultural research system

With the advent of the World Bank-supported National Agricultural Research Project (NARP) in 1991 (Shaib et al., 1997), the National Agricultural Research System (NARS) was formally composed and structured to include the following stakeholders:

- National Agricultural Research Institutes (NARIs) – 16
- Universities of Agriculture – 3
- Faculties of Agriculture in the Universities – 26
- Agricultural Development Projects of the Federal Ministry of Agriculture and Rural Development – 36
- Some prominent Private Organizations
- Consultative Group on International Agricultural Research (CGIAR) comprising the International Institute for Tropical Agriculture (IITA), The International Livestock Centre for Africa (ILCA), and the International Crops Research Institute for the SemiArid Tropics (ICRISAT), also made inputs of generic nature with the NARIs.

The NARS was coordinated by the National Advisory Committee for Agricultural Research (NACAR), an independent body set up by the Federal Government of Nigeria, within the NARP context. A major responsibility mandate was the improvement of the overall focus of research and its relation to agricultural policies and priorities, as well as linking research with policymakers. It also reviewed national research thrusts, and the performances of different institutes, through its five Technical Sub-Committees on crops, forestry and tree crops, livestock, fisheries, extension and training.

To a large extent, NACAR was effective in reinstating (by restructuring) the modus operandi of the Nationally Coordinated Research Programmes, through reasonably harmonized research project task allocation and peer review mechanisms (Adedipe et al., 1997a). Some of the review-mediated coordination schemes such as Monthly Technological Review Meetings and On-Farm Adaptive Research have been retained, since the termination of the World Bank support. However, the effectiveness has declined substantially, given that the coordinating role now performed directly by the Ministry, has not met the set standards by NACAR; a situation earlier predicted by the stakeholders (Adedipe et al., 1997b,c; Shaib et al., 1997). The NARS has also given some level of collaborative participation by the International Institutes of Agriculture to make vital inputs by way of strategic programme interventions.

RESEARCH PLAN PROPOSAL, PROGRAMMING, AND EXTENSION SERVICE DELIVERY

Research plan formulation

As for most Sub-Saharan African countries (Kassapu et al., 1998), Nigeria's weakness in Agricultural research stems from the combined inability to provide the required framework for planning, organization, management, evaluation, and coordination of research programmes on the one hand; and gaps in linkages between research, extension, and farmers on the other hand. Yet, the starting point is the ability to formulate responsive research proposals. As aptly observed by Spencer and Kaindaneh (1988), constraints to research management and results delivery are traceable to weaknesses in human resources. This, therefore, calls for enormous human capacity building, given that a good percentage of research staff do not possess Ph.D.s (Idachaba, 1998) and those who do are not up-to-date in research technological tools. At the moment, a considerable number of agricultural researchers in Nigerian research institutes fall into these two categories. The advent of NARP has, however, stimulated the capacity to formulate the kinds of proposals that will generate time-conscious and production-responsive technologies, including methods of appropriate packaging and assessment. In such cases that satisfy these conditions, the qualified and capable staff and research teams are unfortunately incapacitated by poor funding, to the extent that, in some cases, up to 90% of research budget is spent on salaries and wages (Shaib et al., 1997), leaving very little for the sustainable conduct of research.

Research programming

Research programming is based on the specific mandate of each of the 17 Institutes, three of which are within the university subsystem of agricultural research. These are, notably, the Institute for Agricultural Research and the

National Agricultural Extension and Research Liaison Services (NAERLS) as part of the Ahmadu Bello University, in Northern Nigeria. Its near equivalent in Southern Nigeria is the Institute of Agricultural Research and Training (IAR&T) in Ibadan as part of the Obafemi Awolowo University Ile-Ife. The two engage in multiple crop commodities, and sometimes, particularly the latter, in livestock research. The former has been in existence with interactive relationships since 1924, while the latter came into being in 1969. These university-based research institutes have succeeded for two main reasons; first, reasonably adequate high-level manpower; and second, mutually beneficial research collaboration.

The other research institutes are, largely, independent; and to that extent, lack some of the expected high-level research expertise in the universities.

Without prejudice to this differentiating characteristics of the two, and taking advantage of the World Bank-supported NARP, there was considerable progress in research programme formulation and linkage. In more specific terms, research proposals are derived from the inputs from interdisciplinary team of scientists (Shaib et al., 1997). The review committee of each programme assesses the relevance of each proposal and determines the level of priority. This is done through Nationally Coordinated Programmes (Iyamabo, 1997), which specify themes and priorities. It also outlines the zonal task allocation to participating institutes. The programmes specify objectives and strategies for implementation, including time frame. However, external assessment of research programme is very limited.

Research results communication

Research results are published in the institute technical reports, bulletins and extension pamphlets, while a substantial percentage of the professional staff publish in peer-reviewed Nigerian and International Journals. The university-based institutes, in particular, publish in peer-reviewed Journals since this is an absolute requirement for their personal career advancement.

A recent Journal assessment exercise (Okebukola and Adedipe, 2006) indicated 22 Nigerian agricultural discipline Journals in which most institute research staff do publish. These are among 211 submitted for assessment, some of which are web online.

In addition, there are Annual Reports, with considerable difference in regularity of publication; while there are regular presentations at annual meetings of the specific professional associations and societies (crops, soils, horticulture, animal production, among others).

Research/extension linkages

Extension services date back to 1910, using the Northern and Southern Nigeria dichotomy. This subsequently transformed into the three Regional Government Extension Services in the 1950s, based in their respective Ministries of Agriculture.

This later developed into 5 Agroecological Zones (North-East, North-West, Central, South-East, and South-West of the 1990s to date (Williams, 1994)). For each zone, there are specified coordinating and collaborating institutes, using the Agricultural Development Projects (ADPs) of the Federal Ministry of Agriculture; that is, the Federal Agricultural Coordinating Unit (FACU), which essentially adopts the Training and Visit system, which has also been found to be expensive, and therefore not sustainable. The research-extension linkage model adopted is presented in Figure 1.

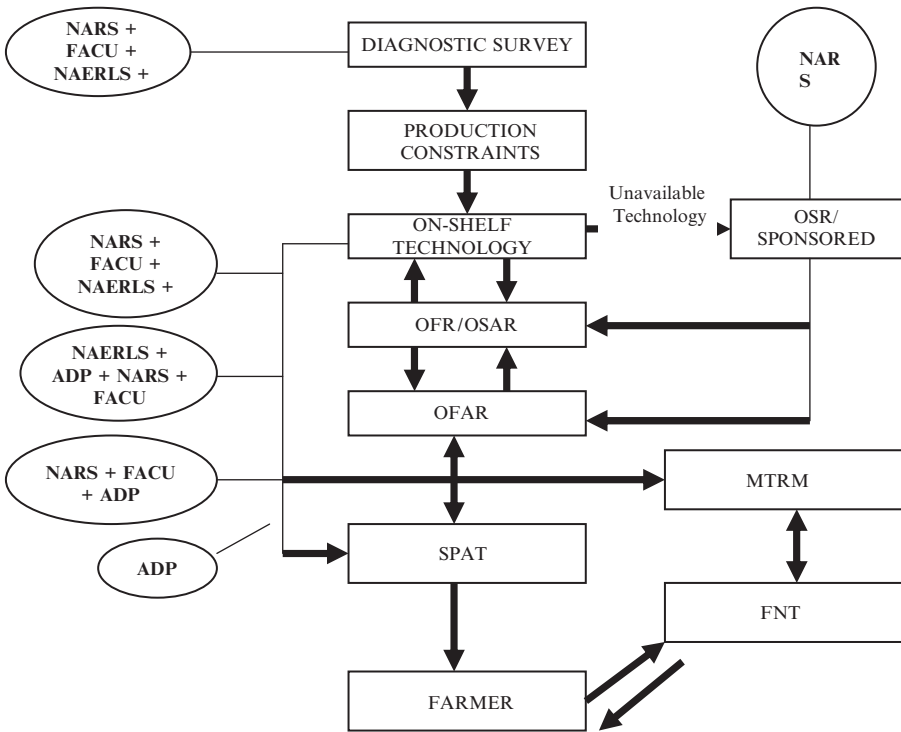

Figure 1. Research / Extension linkage model of NARS.

- FNT – Fortnightly Training
- MTRM – Monthly Technology Review Meeting
- SPAT – Small Plot Adoption Technology
- NARS – National Agricultural Research System
- FACU – Federal Agricultural Coordinating Unit
- ADP – Agricultural Development Programme
- OFAR – On-Farm Adaptive Research
- OFR – On-Farm Research
- OSAR – On-Station Adaptive Research
- OSR – On-Station Research

In recent times, however, the Pilot Villages concept has been introduced. This is primarily based on a combination of On-Station Research (OSR), On-Farm Adaptive Research (OFAR), coupled to Monthly Technology Review Meetings (MTRMs). There is farmer (Grower) participation through the Research-Extension-Farmer-input-Linkage-System (REFILS) (Unamma et al., 2004).

GOVERNANCE AND MANAGEMENT OF NIGERIAN AGRICULTURAL RESEARCH

There are two levels of governance, the first being at the Ministerial level (macro-governance) and the second at the Institute level (minigovernance) (Adedipe, 1994). At the ministerial level, and as indicated above, governance has been unstable. Between 1971 and 2006, there have been frequent changes leading to instability in the ever-changing superintending agencies. Usually, at the ministerial level, the Honourable Minister oversees the entire research institutes, through the Agricultural Sciences Department. This is compounded by frequent changes in the persons of the Ministers, to the extent that the average tenure of a Minister was less than 2 years. This has been reasonably stabilized, with the current Minister being in office for almost 7 years.

The macrogovernance level between 1969 (NCST) and 1971 (ARCN), though short-lived, was the most professionally effective, while the dominant direct Ministerial system has tended to be politicized.

Aside from the World Bank NARP Project period of 1993–1998, which had the National Advisory Council for Agricultural Research (NACAR), there has since been no macrogovernance level body. That role is being played by the Department of Agricultural Sciences, which is one of the 8–10 Departments and associated parastatals of the Ministry of Agriculture, with the stultifying administrative bureaucracy and limited funding.

At the minigovernance level, each Institute is supervised by a Board consisting of private and public sector stakeholders. This level also is very unstable, often with extended interregnum periods. Its main responsibility is to supervise the institute by ways of screening and approving research proposals, approving budgets for capital and running costs, as well as appointments and promotions.

At the management level, the Institute is headed by a professional, variously designated Director, Director-General, or Executive Director. The appointment is by advertisement and interviews by a panel of stakeholders, headed by the Chairman of the Board of the Institute. The Directorate is broken into Divisions with Programme Units. The extent to which an Institute succeeds depends on the management capability and the administration competence/style of the Director/Director-General and the management team. The maximum tenure is now two terms of 5 years each. From the above, the rapid turnover of actors in research is clearly identified as a stultifying and destabilizing factor in agricultural research retardation (Adedipe, 1994; Okigbo, 1994; Idachaba, 1987, 1998). Consequently,

there is the need to address this vital stumbling block to a sustainable agricultural research product delivery.

Financing and budgeting for Nigerian agricultural research

In general, agricultural research is poorly (inadequately) funded. The problem is tripartite: first, the low budgetary subvention; second, the percentage of the approved budget that is actually released; and third is the erratic pattern of release. As with most items, data are very sparse and oftentimes disjointed. A case study is Ahmadu Bello University, which has three of Nigeria's oldest institutes: Institute of Agricultural Research (IAR), which is crop-based; National Animal Product Research Institute (NAPRI); and the National Agricultural Extension and Research Liaison Services. For 1987–1992 for which data are completely available, as in the following profile (Table 1):

Table 1. Budget Profile of IAR, 1987–1992

TOTAL		Million naira		
		IAR	NAPRI	NAERLS
646	Total Budget Request	424	131	91
114	Total Amount Released	60	32	22
18	Received as % Total Request	14	24	24

1 US\$ = 80 naira.

It is obvious that, aside from the low absolute fund allocation, less than 25% was released to any of the three institutes. A more comprehensive and recent data for its Southern counterpart, the Institute of Agricultural Research and Training (IAR&T) as part of the Obafemi Awolowo University, further illustrates the research- funding problem (Table 2).

Table 2. Capital Budget Profile of the IAR&T, 2003–2005

Year	Million naira			Budget released as % proposed	Budget released as % approved
	Budget proposed	Budget approved	Budget released		
2003	125	37	No Release	–	–
2004	253	172	No Release	37	49
2005	276	206	101		
Total	654	415	101	15	24

1US\$ = 130 naira.

Table 3. Recurrent (Overhead) Budget Profile of the IAR&T, 2003–2005

Year	Million naira			Budget released as % proposed	Budget release as % approved
	Budget proposed	Budget approved	Budget released		
2003	90	7	5	6	71
2004	94	3	3	3	100
2005	78	24	19	24	126
Total	262	34	27	10	79

1 US\$ = 130 naira.

Just as for IAR, the percentage of the fund released has been low in the IAR&T (Table 3.). The latter also shows less than 25% over a 3-year period, as recently as 2003–2005. Lack of sustainable funding is clearly evident in the fact that capital funds were not released for 2 years, meaning that existing structures and infrastructures as well as major equipment could not be maintained and serviced, nor could new ones be procured or installed.

As shown above, 79% of the approved budget was released. This means that the Institute could not have maintained the level of staff and consumables for the 3-year period. Only 10% of the proposed budget was released, indicating that the funding level requested to enhance capacity (number and mix of research staff) as well as matching levels of consumables and services was depressingly far from being attained.

These two data-supported examples are typical of the Research Institutes since they draw their research funds from the same Ministry of Agriculture, as part of one Department of Agricultural Sciences requesting and distributing funds from a pool meant for over 8 Departments and a number of parastatals of the Ministry. Also, the agency responsible for Extension Services (to deliver agricultural research technology generated by the Institutes), as recently as August 2006, stated (Banta, 2006):

the system put in place to ensure that the farmers benefit from the technologies emanating from researchers has remained inadequately funded.

Part of the solution lies in a reasonably independent supervisory body like the defunct Agricultural Research Council of Nigeria (ARCN) as was the case.

Periodic external reviews of performance

The only comprehensive external review was carried out December 2–19, 1996 as part of the World Bank- supported National Agricultural Research Project (Federal Ministry of Agriculture and Natural Resources, 1996). The two key Terms of Reference (TOR) were:

Review and assess the agricultural research institutes; and make recommendations that would enhance the effectiveness and efficiency of the research institutes.

The External Review Panels constituted three groups:

1. Arable crop-based research institutes, with panel members from ISNAR, the Hague, as Chair; INERA, Burkina Faso; WARDA, Cote d'Ivoire; NARP, Ghana; former Minister of Agriculture, Nigeria
2. Forestry and tree crop-based research institutes, with panel members from FAO, Accra; Nigerian Horticultural Private Consultant; Nigerian Public Consultant
3. Livestock, fisheries and research extension linkages, with panel members from CORAF; FARA; Nigerian Public Consultant

These external members were drawn from African subregional agricultural research coordinating agencies.

Overall, the External Review Panel, after considering the TOR (involving structures, infrastructures, staffing, programme profile, management, and financing), made far-reaching **generic recommendations**, prominent among which were:

1. Rationalization of organizational administrative structure into well-defined Techno-professional Divisions
2. Installation of a Divisionalized Budget System to enable the Divisions carry out their mandate-driven functions effectively, thus ensuring devolutionary accountability and transparency in financial management
3. In the light of the successful implementation of the Nationally Coordinated Research Programmes (NCRPs), emanating from the National Agricultural Research Strategy Plan (NARSP), the need for resource-consuming, elaborate sub-stations, has become unnecessary
4. The emplacement of an organized Committee System as a means of effective consensus-building in the key areas of the Institutes' functions and operations, including, for each institute:
 - Management committee
 - Tenders and procurement committee
 - Works and services committee
 - Seminar and publications committee
 - Institute marketing and revenue generation committee
5. Appointments of Directors to be by Interview Panels with external membership as do obtain in respectable research institutes the world over and in the Nigerian University System
6. Adoption of Coordinated Agricultural Research Management Information System (CAREMIS)
7. The ratio of researcher to non-researcher, then lopsided in favour of non-research staff, should be reversed
8. Given that the research institutes started operating the University Salary Scale, and in anticipation of the return of the Agricultural Research Council

of Nigeria, they should no longer operate strictly by the stifling and stultifying civil service regulations.

9. Macro structural reorganization to have the research institutes in each region/zone attached to the then recently established Universities of Agriculture; given the better overall performances of the Institute of Agricultural Research (IAR) affiliated to the Ahmadu Bello University; and the Institute of Agricultural Research and Training (IAR&T) affiliated to the Obafemi Awolowo University

In addition, specific recommendations associated with the particular structures, functions, and mandate profiles of each institute, were also made.

Unfortunately, only a few of these recommendations have been formally adopted and/or implemented. There is thus a need for another external review, 10 years after the only one so far carried out; and at fairly regular intervals thereafter.

SCIENTIFIC STAFF PERSONNEL MATTERS

Recommendations 6. and 7. resulted from the unsatisfactory personnel matters observed. There were little or no:

- Compulsory tenure prescriptions
- Compulsory interviews including external assessment and associated peer review mechanisms
- Consistently transparent promotion criteria and process, thus leading to unnecessary stagnation, among others

Lately, progress has been made on some personnel issues. In particular, the heads of the institutes have now been elevated to the status of Executive Directors with stipulated tenure terms, and the creation of multiple Directorships for defined programme clusters, to enhance career prospects and job satisfaction. Also, staff without Ph.D.s can no longer advance to the senior positions of Assistant Directors and above.

PROBLEM PROFILES OF THE NIGERIAN AGRICULTURAL RESEARCH SYSTEM

As discussed above, the problem profiles of the Nigerian Agricultural Research System, and as analyzed in detail by Adedipe (1979, 1988), Okigbo (1994), and Idachaba (1987, 1998), can be summarized as follows:

1. Instability associated with frequent changes in the overall supervisory organ of the research institutes
2. An overburdening system of administration resulting from too many institutes in relation to the assigned mandates, capital and running costs in the face of limited research funding
3. Overlapping research mandates of the institutes and often-conflicting professional functions of professional staff

4. Professional research manpower instability (brain drain); locally to universities, and internationally elsewhere
5. Research programme inconsistency and non- durability
6. Grossly inadequate funding, exacerbated by irregular and incomplete budgetary releases
7. Lack of, or outdated, research equipment and facilities including deficient libraries and slow pace of virtual (electronic) library development
8. Dearth of data for Management Information System
9. Lack of periodic major external reviews of research programmes in relation to assessed achievements, and prescription for new directions

SUMMARY AND CONCLUSION

Nigerian Agricultural Research dates back over a century, with the establishment of a unified Department of Agriculture. It has transited into various formats, in three statutory generations:

- The first generation of national research departments (1893–1955)
- The inter-territorial West African research institutes of the colonial administration (1944–1954)
- The second generation of national research institutes (1975–2006)

These have culminated in the present 16 Agricultural Research Institutes, which are primarily commodity-based. Of significance are two institutes that are university-based and which have mandate for multiple commodities; and which, therefore, essentially serve as coordinating research centres for food crops and livestock.

The institutes have so far been governed and managed by direct civil service rules and regulations, which have prevented them from expressing their full potentials of professional capabilities. This structure has, inadvertently, led to serious financial constraints that have minimized their research output and technology delivery for enhanced agricultural productivity, aimed at food security. New visions such as those of organic fertilizers as part of organic waste management, (Adedipe et al., 2005); seed technology research and the wide adoption of Agricultural Management System (Balagura et al., 1996), would need to receive proper attention towards environmental and biotechnological aspects of sustainable agricultural production.

There has been a rapid turnover of governance structures, while management principles and best practices of reasonable autonomy, transparency, accountability, and the recognition of professional staff inputs, efficacious research output, publication, and farmer inputs, have been limited. There are encouraging changes to address these weaknesses. However, such promising trends need be accelerated through more formally binding linkage mechanisms of the universities (where the professional expertise abound) with research institutes (where commitment to national priorities is the order). This needs to be coupled to more productive and need-prescribed institutional arrangements with

reasonable levels and timely release of funds. It is only by so doing that external capacity building intervention can take root for sustainable productive agricultural research. In this regard, the Asian experience is noteworthy in terms of a sustainable changes strategy.

REFERENCES

- Adedipe, N.O. 1979. Combining Basic and Applied Research in a Nigerian Agricultural Faculty. Symposium on Resource and Results Oriented Research in Nigerian Agricultural Institutes and Faculties, Institute of Agricultural Research and Training, Ibadan, University of Ife, Ile-Ife.
- Adedipe, N.O. 1988. Thoughts on Academic Programmes and Research in Nigerian Universities of Agriculture. National Seminar on Universities of Agriculture, National Universities Commission, Kaduna, Nigeria.
- Adedipe, N.O. 1994. Agricultural research organization in Nigeria. In: Shaib, B., Adedipe, N.O., Odegbare, O.A., and Aliyu, A. (eds.) *Towards Strengthening the Nigerian Agricultural Research System*. National Agricultural Research Project, Federal Ministry of Agriculture and Rural Development, Abuja, Nigeria, pp. 215–236.
- Adedipe, N.O., Aliyu, A., Ahmed, H.U., and Fagade, S.O. 1997a. Green revolution concept and agricultural research implications for food security in Nigeria. In: Shaib, B., Adedipe, N.O., Aliyu, A., and Jir, M.M. (eds.) *Integrated Agricultural Production in Nigeria: Strategies and Mechanisms for Food Security*. National Agricultural Research Project, pp. 230–241.
- Adedipe, N.O., Bakar, J., Krogmann, U., and Sridhar, M.K.C. 2005. *Waste Management, Processing and Detoxification Millennium Ecosystem Assessment*, Vol. 3. Policy Responses Working Group, Island Press, Chicago.
- Adedipe, N.O., Bakshi, J.S., and Aliyu, A. (eds.) 1997b. The Nigerian Agricultural Research Strategy Plan and Extension Delivery: Policy Concept and Consensus to the year 2010. National Agricultural Research Project Monograph No. 7. National Agricultural Research Project, Ibadan, Nigeria.
- Adedipe, N.O., Bakshi, J.S., and Aliyu, A. 1997c. Summary. In: Adedipe, N.O., Bakshi, J.S., and Aliyu, A. (eds.) *The Nigerian Agricultural Research Strategy Plan and Extension Delivery: Policy Concept and Consensus to the year 2010*. National Agricultural Research Project, Ibadan, Nigeria, pp. 440–451.
- Balaguru, T., Manikandan, P., Kalla, J.C. 1996. *Management Information System for Agricultural Research*. National Academy of Agricultural Research Management, Hyderabad, India.
- Banta, T. 2006. Research- Extension-Farmers-Input-Linkage System (REFILS). Stakeholders meeting, National Root Crops Research Institute, Umudike, Nigeria.
- Federal Ministry of Agriculture and Natural Resources. 1996. National Agricultural Research Project. Report of the External Review Panel on the National Agricultural Research Institutes.
- Idachaba, F.S. 1987. Agricultural research in Nigeria: Organization and policy. In: Ruttan, V.W. and Pray, C.E. (eds.) *Policy for Agricultural Research*. Westview Press, Boulder, CO, pp. 333–362.
- Idachaba, F.S. 1998. Instability of National Agricultural Research Systems in sub-Saharan Africa: Lessons from Nigeria. International Service for National Agricultural Research (ISNAR), The Hague, The Netherlands, Research Report 13.
- Iyababo, D.E. 1997. Concept and implementation of nationally co-ordinated research programmes. In: Adedipe, N.O., Bakshi, J.S., and Aliyu, A. (eds.) *The Nigerian Agricultural Research Strategy Plan and Extension Delivery: Policy Concept and Consensus to the Year 2010*. National Agricultural Research Project Monograph No. 7., Ibadan, Nigeria, pp. 22–33.
- Kassapu, S.N., Adedipe, N.O., and Norman, J.C. 1998. Summary. In: Technology Assessment and Transfer towards Food Security and Poverty Alleviation in Sub-Saharan Africa. Food and Agriculture Organization, Rome, Italy, pp. 13–32.

- Okebukola, P., and Adedipe, N.O. 2006. *Catalogue, Ranking and Grading of Scholarly Journals* published in the Nigerian Higher Education System. National Universities Commission, Abuja, Nigeria.
- Okigbo, B.N. 1994. Agricultural research policies, objectives and priorities: a critical review. In: Shaib, B., Adedipe, N.O., Odegbare, O.A., and Aliyu, A. (eds.) *Towards Strengthening the Nigerian Agricultural Research System*. National Agricultural Research Project, Federal Ministry of Agriculture and Natural Resources, Abuja, Nigeria, pp. 27–74.
- Shaib, B., Aliyu, A., and Bakshi, J.S., 1997. *Nigeria: National Agricultural Research Strategy Plan 1996–2010*. Department of Agricultural Sciences, Federal Ministry of Agriculture and Natural Resources, Abuja, Nigeria.
- Spencer, D.S.C., and Kaindaneh, P.M. 1998. Farming systems and environmental considerations in technology assessment and transfer in sub-Saharan Africa. In: *Technology Assessment and Transfer towards Food Security and Poverty Alleviation in Sub-Saharan Africa*. Food and Agriculture Organization, Rome, Italy, pp. 65–95.
- Unamma, R.P.A., Onwudike, O.C., Uwaegbute, A.C., Edeoga, H.O., and Nwosu, A.C. 2004. *Linkage Strategy for Sustainable Agriculture in Nigeria: Research-Extension-Farmer-Input-Linkage-System*. Michael Okpara University of Agriculture, Umudike, Nigeria.
- Williams, S.K.T. 1994. Agricultural Research Planning and Programming. In: Shaib, B., Adedipe, N.O., Odegbare, O.A., and Aliyu, A. (eds.) *Towards Strengthening the Nigeria Agricultural Research System*. National Agricultural Research Project, Ibadan, Nigeria, pp. 91–114.

CHAPTER 15

INRA – NATIONAL INSTITUTE FOR AGRICULTURAL RESEARCH

From the local to the global levels

MICHEL DODET

Vice President International, INRA, 147 rue de l'Université, 75338 Paris Cedex 07 France

INRA'S MISSIONS: A HISTORICAL REMINDER

INRA, the French National Institute for Agricultural Research (see Annex 1), was set up in 1946 and is a public-sector establishment whose activities cover the areas of agriculture, diet and nutrition, and the environment. It is the leading European agricultural research agency in terms of its scientific yield in the life sciences (animals and plants) and the environment (its core mission) and the second largest in the world behind the ARS-USDA. Its missions are research, the transfer of research results and their exploitation, international cooperation, the dissemination of scientific and technical information, training in research and through research, expertise and decision-making support for government policies.

There have been four critical stages in the history of INRA, aligned with developments in agriculture and French society on the one hand, and with research in general, and the French research and innovation system in particular, on the other hand.

At the end of the Second World War, French farming was in a parlous state, but the food shortages, which prevailed at that time, had more profound causes, going back to the farm policies implemented since the end of the 19th century. French farming was lagging behind that in other major developed countries, and the task entrusted to INRA at its inception was to mobilise science and technology to the service of agricultural development: to improve cultivation and animal husbandry techniques, and ensure the genetic improvement of plant and livestock resources. These research programmes were an integral part of plans for major post-war modernisation and gradually enabled French farming to master its activities and become increasingly productive, more specialised and more regionalised. INRA could also draw support and cooperation from

technical institutes and technical support agencies for farm development, and the growth of partnerships with professional farming organisations.

By the early 1970s, it was easy to see that the efficiency of the system thus implemented by the government had exceeded all expectations. Not only had France become globally self-sufficient in terms of food supplies, it had also become an exporter in certain sectors. INRA had played its role in this, but once the quantitative objectives had been attained (and even exceeded, because the first farm surpluses were now appearing), it was then called upon to mobilise its scientists to target the processing of agricultural raw materials, and address questions concerning the quality and added value of products. This was a turning point for the agrifood sector, marked by the development of microbiology and engineering sciences on the one hand, and close partnerships with industry on the other hand.

These two successive periods constituted two successes for INRA and promised a sustained future for the Institute in the areas of agriculture and diet and nutrition. At the same time, INRA was starting to concern itself with environmental problems (low-input farming) and rural development (faced with the growth of specialisation). These two periods also corresponded to construction of the French research and innovation system where research, the “preference for the future” was protected from the contingencies of the present by strong inter-ministerial coordination by the Prime Minister and through the specific allocation of funds by the Government. Thus the growth in INRA resources, which remained under the authority of the Ministry of Agriculture for its general orientations, was assured, enabling it fulfil and develop its missions.

Once the agrifood page had been turned, INRA found itself confronted by a series of major upheavals: agricultural overproduction and questions about the pursuit of high yields, a dramatic growth in environmental problems and questions about farm practices, questions about the Common Agricultural Policy of the European Union, both internally and externally, the rise of biotechnologies and the acceleration of scientific competitiveness. During the 1980s, INRA attained a scientific maturity that anchored it in a broader community in terms of the scope of its investigations (the environment) and the scientific disciplines it fostered (growth in the share of basic research and the rise of molecular and cellular biology). This maturity also corresponded to that of the French research system, whose openness to international competition was confirmed and amplified and whose missions were becoming broader (to the traditional mission of acquiring new knowledge was added that of its transfer for the benefit of economic, social and cultural development). Impetus for these changes came from the Ministry for Research that prevailed over the orientation ministries (such as the Ministry of Agriculture for INRA) so that the Institute now found itself under the dual tutelage of both the Research and Agriculture ministries.

The final period confirmed these transformations for INRA, which would now fully invest the field of environmental research, reversing previous perspectives in order to situate farm production within the functionalities of the ecosystem and to take better account of knowledge on and the preservation of

natural resources. It also confirmed the opening of the field of nutrition alongside and as a complement to that of diet. More largely, these evolutions should be considered as a firm commitment to the requirements of sustainable development. This therefore overturned the founding paradigm of agricultural research, in that it was now aligned with the expectations of society. These developments were also made possible by evolutions in the scientific activities of the Institute. Indeed, major changes are now affecting the life sciences, environmental sciences and social sciences, which form the foundations for INRA research. High throughput biology, informatics and data analysis techniques have opened new perspectives for the study of complex phenomena such as integrative biology or agricultural, environmental or dietary systems.

While reaffirming the essential need for high yields and economic productivity, to which its work must contribute, INRA also has a duty to contribute to evolutions in current farming and industrial practices so that they become more environmentally friendly and better adapted to human nutritional requirements.

Sustainable development in all its forms has become an unquestionable objective, even if the means of achieving it is the subject of much debate and the social, ecological and economic challenges particularly complicated. Although there is a permanent need for its adaptability, farming must remain economically viable and competitive, a source of employment, environmentally friendly and produce well-balanced, healthy foods. Thus the environment, or the exploitation of renewable carbon sources, have become research challenges in their own right, and are no longer subjects of investigation deduced from other work. Similarly, the use of biomass as an energy source is becoming an economically realistic prospect, and the conditions for its sustainability, as well as its repercussions on the food industry, must be studied.

The French research and innovation system will probably see considerable change during the next few years, with more polarisation of its resources, greater incentives for the transfer of results and collaborative projects, and international openness in the context of focused cooperation. By encouraging competition between the principal components of the system at an international level, construction of the European Area for Research and Higher Education will oblige research agencies such as INRA to review their scientific and partnership strategies, so that they can move outside a national context and form part of an operational dynamic of European dimensions.

In addition to situating the general context for the management of agricultural research¹ in France, this brief history of INRA shows that its challenges have evolved over time. Its management will now need to orient its procedures and practices over time so as to ensure the consistent quality of INRA results

¹ Throughout this chapter, the term “agricultural research” means all research concerning agriculture (production and processing of agricultural products), diet and nutrition, the environment and regional development.

and the relevance of its activities. Six major questions, which also coincide with management challenges, are studied below: determining priorities (i.e. the conditions for the construction of a strategic vision), scientific organisation and management (i.e. how to implement these challenges within an appropriate management structure), international cooperation (i.e. the new scale of agricultural research), expertise (an inseparable extension of research) and finally, the ethical bases for agricultural science.

DETERMINING PRIORITIES: PROCEDURES AND STRUCTURES

INRA's activities lie at the crossroads of its socio-economic and scientific contexts, and aim to respond to questions of different types and from different sources, which may be both theoretical and mission-oriented. The Institute must be able to raise the right research questions (those which appear to constitute priorities in the thematic fields concerned) and to generate new knowledge in the scientific disciplines thus mobilised.

This definition of INRA's activities covers all the problems faced when determining priorities.

Three major questions arise for an agency situated at the confluence of socio-economic (expectations expressed by society) and scientific (the ambitions and responses allowed by scientific advances) contexts, which needs to ask the correct research questions:

- How are society's expectations perceived, identified and then determined, and who expresses them?
- How can science and these expectations be brought together, i.e. how can these expectations be translated into research questions?
- What approach should be adopted towards pertinent advances in science (all sciences) so that a research project can be developed which will respond to these expectations?

These three problems are clearer today than they were in the past, when determining research priorities did not always involve the same structures. There are two principal reasons for this.

The first results from the challenges themselves: when the aim is to mobilise science in order to achieve self-sufficiency in terms of food supplies, the scientific approach may be complex but the priority is clear and based on measurable factors. There is then no need to set up a complicated consultative system and to construct consensus opinions in order to identify the needs of society. This is certainly no longer the case in a society that has become more complex, richer and more open to the world, where most primary needs have been satisfied.

The second results from evolutions in the status of research in a developed society. During the thirty years, which followed the Second World War, citizens entrusted scientists with the task of creating new knowledge and ensuring the development of advances that would improve their standard and quality of life. This was a relatively linear progression. In a society, which is globally richer, better trained and better informed (or at least has unprecedented access

to information), this is no longer the case. Determining priorities in this context requires broader, more democratic debate through a process, which to a great extent, still needs to be invented and then implemented.

As a mission-oriented research agency, INRA needs to be able to identify and anticipate the societal challenges concerned by the scope of its activities. Since 1993, it has developed the specific ability to carry out prospective studies concerning both the challenges and endogenous dynamics of science, so that it can develop scientific issues in interaction with other major players in response to demands for the quality of its research and in order to ensure that this research will produce answers to practical questions.

The only way a mission-oriented research agency can respond to these needs is to ensure that a system exists for mutual exchanges and interaction between the different economic and social actors concerned: those responsible for public policies in the relevant area of competence, industry both upstream and downstream, technical centres, producer cooperatives and organisations, associations active in the environment and consumer affairs, and those responsible for managing regions and natural resources. These numerous links mean that INRA is able to perceive some of society's expectations and then integrate them in its strategies and the resulting programmes and projects.

This diversity of partnerships generates differing relationships between society, science and innovation. It also means that greater attention must be paid on both sides to balancing the interests and motivations in play, and setting methods and relationships against the construction of research questions.²

Faced with these needs, INRA strives to promote an organisation and processes, which are easily accessible and comprehensible in the setting of its partnerships. Three orientations deserve to be highlighted in this respect:

- The creation of better organised systems to obtain, analyse and take account of the needs of partners in response to three objectives: limiting the risk of bias when weighing up the interests in question, guaranteeing identification of the scientific challenges which must govern programming, and clarifying the links (or lack of links) between the expression of needs and the choice of programmes.
- Based on the experience acquired by both INRA (prospective studies) and agencies in other countries (particularly the United Kingdom), the development of more systematic methods to consult partners about the orientations of agricultural research, laying emphasis on long-term strategic questions when identifying research needs.
- Improved exploitation at the different organisational levels of the Institute of numerous, strong partnerships, so as to continue to perceive the emergence of new questions at an early stage.

² All systems and procedures described in this section in terms of Institute management result at another level in discussions with Ministerial bodies, leading firstly to a targeted contract between INRA and the Ministry responsible for its activities, and secondly to projects for the national programme on "Research in the field of environmental and resource management", in which INRA is a contributory partner.

Although this orientation partnership is essential to determining research priorities at INRA, it is only possible in the setting of a dynamic and well-balanced relationship with the general current of research and changes to its concepts and tools. This dynamic equilibrium is a prerequisite for agricultural research, which will efficiently combine both scientific excellence and social relevance. Agricultural research is thus an excellence illustration of "mode 2" research organisation, while developments in its management are informed at the same time by theoretical thinking which has led to the definition and formalisation of this organisational and functional mode.³

The numerous links sustained by INRA with all partners in agricultural research have enabled the development of its institutional strategy. Its different structures (units, centres, research departments) participate in this, while remaining in direct contact with these partners.

SCIENTIFIC ORGANISATION

Today, INRA has a dual function: it plays a traditional role as an agency carrying out agricultural research in its laboratories, and a newer role as a provider of funds for the entire scientific community involved in its field of competence.⁴

In the former role, its structure is one, which is quite classic (in France), being made up of research units (260) grouped into 14 scientific departments (see Annex 2).

Research Units thus provide the basic foundations of INRA, and they may in turn be made up of various teams. Units may be of varying size, and form the basis for a single scientific project or a coordinated series of projects. These are defined together by the Unit and the Department to which it is attached as being the best possible combination of the scientific skills available in the Unit and the strategic scientific objectives of the Department. Research Units undergo four-yearly evaluations.

In recent years, Units have evolved in terms of their nature and no longer constitute the only possible and useful format for scientific organisation. The historical separation in France between universities and public research agencies is increasingly being corrected by the organisation of functional collaborations at the basic level of scientific organisation, within Joint Research Units where researchers from INRA and universities share their resources to work together on a joint project. Thus, in the case of INRA, more than half of its Units can now be defined as Joint, where researchers work with colleagues from universities, agricultural or veterinary schools or more generalist institutions. This

³ "The new production of knowledge: the dynamic of science and research in contemporary societies" (M Gibbons et al, 1994. In: "Rethinking science", H Nowotny, P Scott, M Gibbons, 2003).

⁴ This role is delegated by the Agence Nationale de Recherche (ANR) (National Institute for Research), which provides funds for research at a national level in all scientific fields. This delegation implies a contractual relationship between the ANR and INRA which determines the duties of the latter towards the former, in terms of both functioning and funding.

trend, which means that INRA research benefits from input from a thousand university researchers who devote a large share of their working time to these activities. It has enhanced the openness of INRA towards disciplines which were previously under-represented or marginal, and thus made it possible to attain the critical mass necessary for a broader approach to agricultural research targets. It has also enabled work in new fields, such as nutrition, in collaboration with appropriate medical research teams. Research Units have also seen change through the development of agricultural research tools and the diversification of approaches. In this context, a Research Unit format is no longer relevant in all cases, and groups of units (some belonging to INRA, some belonging to other research agencies) within Federative Research Institutes have been developed. They enable the pooling of increasingly costly and sophisticated technical resources, as has already been the case in other scientific fields, such as medical research⁵ Thus the frontiers of an agency such as INRA are already becoming less well defined than they may have been in the past. Ongoing reforms to the organisation of French research have opened new perspectives for local or theme-based groups, which may extend beyond research per se, but nonetheless include it, such as poles of competitiveness. Although the trends arising from these reforms are still in their infancy, research managers are faced with new challenges and INRA must reflect on how a series of much more heterogeneous structures should be managed. It may be necessary to invent new management methods will maintain the essential coherence of a global policy while allowing for the adaptation of tools to take account of local diversity. Evidently, this is even more relevant to the international development of research activities.

Research Departments constitute the intermediate structure within INRA, covering a coherent disciplinary field. Each Research Department is headed by a Director, appointed for a four-year term, renewable only once. Departmental Directors are assisted in their decision-making by Scientific Council and a Management Board.

To simplify, it can be considered that they lie at the interface between the endogenous dynamics of science (specific to the Units which they contain) and the more global policies of INRA, working downstream with Units and upstream with the Management Board. They thus have an essential role to play in the operational planning of research resulting from these dual relationships. This is synthesised in the four-year strategic plan, which is debated within the Department, examined by its own advisory structures and then validated by the Management Board. Based on INRA's overall orientations, these strategic plans are drawn up and examined contemporaneously so as to ensure a coherent

⁵ In this respect, it should be pointed out that alongside its Research Units, INRA also has 80 experimental units which constitute an essential resource for the acquisition of scientific data generated in the context of observations or interventional protocols and as a result of interface with industry. They also enable the conservation of genetic resources. Their roles and functions are also changing considerably at present, and their resources (animals or plants) tend to be organised in technical platforms, in poles or networks, some of which are open to INRA's technical or industrial partners.

approach for the Institute's activities and to allow the emergence and implementation of cross-departmental action plans. Departments are encouraged to identify these actions in order to prevent INRA from fragmenting into as many independent institutes as there are departments. This planning framework lies down the instruments for the scientific management of the Department, the allocation of resources, the evaluation of Units and that of the Department itself.

At the level of INRA's Management Board (see the section on management), a consultative Scientific Advisory Board⁶ participates in the leadership and management of research by commissioning analyses of the current situation and prospective studies in some of the scientific fields covered by INRA. This Board emits its opinions on the missions entrusted to Department Heads and Scientific Directors and ensures the satisfactory implementation of evaluation procedures and in particular, the monitoring of departmental evaluations.

In its second role as an agency funding agricultural research, INRA has needed to develop an organisation, which is markedly inspired by models existing in other countries, notably with respect to independent evaluation. Indeed, the management method retained guarantees the impartiality of a system, which provides a framework for activities and then selects projects. In practice, the design of calls for tender involves all interested parties. The members of different committees are appointed as a function of their individual abilities, regardless of their institutional affiliation, and deontological rules have been laid down to prevent any favouritism. The procedure leading to the choice of projects to be funded is probably more novel, and involves two bodies. The first is a scientific committee that ensures peer-review and thus guarantees the scientific quality of projects that might be retained. Once these impartial choices have been made, a strategic committee then makes the final decision based on criteria concerning a programme's relevance to the more global objectives. Thus, for example, in the diet and nutrition programme, both socio-economic, industrial and public health criteria are involved in the final choice of projects. In 2005, INRA led and managed five programmes on behalf of the ANR:

- Agriculture and sustainable development
- Diet and human nutrition
- GM organisms
- Genomics in livestock ("Genanimal")
- Plant genomics ("Genoplante")

The most interesting aspect of this new function entrusted to INRA is certainly the influence it will have in the longer term over the actual organisation of INRA and its relationships with agricultural research as a whole. The fact that INRA teams are more regularly placed in competition with outside teams in the context of calls for tender, and are thus subject to comparative evaluation, will inevitably lead to a redistribution of skills and a restructuring of the national research system. Such changes will be based on an evaluation of the quality

⁶The Scientific Advisory Board has 26 members; 9 of them are elected, 13 are appointed and four are *de facto* members, including President of INRA. It is appointed to serve for a period of four years.

and pertinence of research, comparing units specific to the Institute and those belonging to other institutions, all considered in a more global and coherent context of research in the areas of agriculture, diet and nutrition and the environment. The modes of action are also very likely to undergo profound review.

Clearly, evaluation forms the cornerstone of scientific organisation. This has been reinforced in recent years. At INRA, as in all other French research agencies, evaluation concerns not only the individual evaluation of researchers (see below management of human resources) but also the collective evaluation of Units, Departments and programmes. The principles of transparency, independence and openness that ensure its legitimacy are naturally applied, and the majority of evaluation commission members are invited from outside INRA, often from other countries (this is systematic when research departments are being evaluated). Under an approach consistent with the diversity of the Institute's missions, evaluations always highlight the need for greater alignment between the missions, which respond directly to the major socio-economic challenges addressed by INRA and high-level cognitive research. This problem of evaluation in a context of mission-oriented research means that the Institute pays particular attention to evaluation in "mode 2" of research organisation (see above) and to recent developments concerning the evaluation of complex programmes, linked programmes or complex systems. Finally, INRA is attentive to the effects of evaluation on career development, resource allocation and evolutions in the research system for which it is responsible.

MANAGEMENT

A matrix managerial model

INRA is headed by a President who acts as both Chairman of the Management Board and Director-General of the Institute. This combination of two previously separate functions was implemented in 2004 in order to strengthen the ties between strategic and operational responsibilities, and to improve the consistency of management activities.

Operational management of the Institute is shared by two Deputy Directors-General, one responsible for scientific programmes, resources and evaluation, and the other in charge of research support services. This structure thus makes a distinction between scientific and management responsibilities, but they are combined under the authority of the President when a research policy is implemented which explicitly integrates these two dimensions.

This structure is supplemented by five Scientific Directors who cover the entire scientific remit of INRA (Animals and Animal Products, Plants and Plant Products, the Environment, Cultivated and Natural Ecosystems, Human Nutrition and Food Safety and Society, Economics and Decision-Making). Prior to 1998, Scientific Directors had operational responsibilities for managing the research areas they covered. But a simplified management system was

introduced at that time, which entrusted Scientific Directors with a more strategic functional mission as well as scientific leadership in their areas of competence. Under the President and the Deputy Directors General, they constitute a Management Board, which defines and implements the Institute's strategy.

INRA's activities in the field are mostly carried out in facilities, which belong to the Institute and are grouped into "Research Centres". Each centre is headed by a President, who also represents INRA at regional level. He is assisted by a local administrative staff. These usually contain Research Units covering a variety of disciplines (and thus belong to different Research Departments), even if there has been a certain tendency towards the specialisation of centres in some areas, inducing an increasing polarisation of INRA's research resources. Nonetheless, these Centres do not constitute a simple juxtaposition of unlinked units: there is an increasing trend towards the pooling of resources within joint technical platforms, and the construction of common approaches. Furthermore, Centres also have the task of integrating INRA resources in the regional scientific community as a whole, so as to enable useful synergies. Finally, they provide a focal point for active exchanges under different professional, socio-economic or social partnerships, etc. So although they provide a point of contact with the scientific or socio-economic environment in its broadest sense, they have no responsibilities regarding the determination of priorities.

If the organisation of INRA is analysed in terms of the scientific structure of the Institute, and if we look upwards from the point of view of Research Units rather than downwards from the top, it is clear that a matrix-type system has developed. Indeed, each Research Unit belongs not only to a Centre (and is thus integrated in a scientific, professional, economic and social context) but it also reports to a Research Department, which provides its strategic and thematic framework. Thus, a Unit will have two interlocutors at any one time. The problem with this type of organisation is two-fold: firstly, both interlocutors must be able to reach agreement and provide pertinent responses to the Unit, and secondly, these two actors need to interact when defining the scope of decision-making. In response to the first point, Centre Presidents meet once a year with each head of department so that any questions concerning the operational management of units can be discussed. In practice, the second point requires the definition of how much delegation is given to both Centre Presidents and Department Heads. The changes, which have led INRA from a pyramidal, hierarchical organisation to a matrix system mean that the problem of sharing responsibilities between the "corporate" level and those immediately below, has not yet stabilised. This is exacerbated because global developments in the French research system (see above) mean that the problem requires constant review.

Decisions concerning INRA's global strategy and overall control of the Institute's activities (strategic orientations, general organisation, four-year strategic plan, budget and accounting, annual report) devolve to the Board of Directors. This is the only decision-making body at INRA, the others being purely consultative, so that it carries particular weight in management of the

Institute. Its composition broadly reflects INRA partnerships and thus ensures a forum for debate regarding the challenges falling within the scope of the agency's mission. Thus the Board of Directors has the following membership:

- Representatives from government ministries concerned by INRA research activities (Agriculture, Research, Economics and Finance, Industry, Health, Ecology)
- The Chairman of the Scientific Advisory Board
- Four representatives from professional farming organisations
- Two representatives from agriculture-related industrial sectors
- One representative from the agricultural supplies industry
- One representative of consumers
- Two representatives of agricultural employees
- Four elected representatives of INRA staff

This composition is still strongly slanted towards the initial remit of INRA in the areas of agriculture and the agrifood industry, while other, more recent challenges (the environment and sustainable development) are only represented through the Ministries responsible for them.

Budget and resource allocation

The INRA budget for 2006 was €680 million, of which €577 million came from the Government and €103 million from other sources, either from the agency's own activities or from public or private sector contracts. These sums only correspond to the in-house research activities carried out by INRA; its activities as a funding agency account for a further €47 million in credits.

With respect to its internal activities, the INRA budget can be broken down into three sectors:

- Activities carried out by research departments and units (76.6% of the budget)
- Joint actions (major infrastructure, exploitation, dissemination of scientific and technical information, international cooperation) (5.1% of the budget)
- Research support (17.9% of the budget⁷)

The share of the budget devoted to activities carried out by research departments and units is broken down initially by department, based on a researcher allocation modulated as a function of the type and cost of the research conducted by each individual. These are therefore quite similar in all biotechnical departments on the one hand and in social sciences and modelling departments on the other. Credits are then shared within a department between two

⁷ It should be noted that this sector includes property investments (construction of new scientific facilities and the modernisation of existing installations), which account for 3.9% of the budget and which are not of a fundamentally different nature from the joint actions in the second sector. The resources actually devoted to research support in the strictest sense thus only account for 14% of INRA's budget.

allocations, one attributed directly to research units and the other reserved for project funding. Thus, at the level of a Research Unit, the budget (not including staffing costs) is broken down into three parts: a department-based flat rate financing credit⁸, projects funded by calls for tender by the department (or more exceptionally today, by national INRA calls for tender) and projects funded by external calls for tender, including those managed by INRA on behalf of the National Research Agency. On average, this latter share usually accounts for a little more of 50% of resources, not including the staffing costs of units.

Human resources

All INRA staff, researchers and technicians, benefit from the status of civil servants, recruited on the basis of national competitive entry. Researchers belong to two groups:

- Researchers, corresponding to positions as junior researchers, recruited after a doctorate (and usually after initial experience as a postdoctoral researcher) by *ad hoc* juries. At least half of the members of these juries are experts from outside INRA, and the juries are chaired by Scientific Directors. Unlike other French research agencies, INRA strives to recruit researchers as early in their careers as possible, so as to enhance the attractiveness of agricultural research,⁹ even if it may be necessary to organise postdoctoral attachments after recruitment.
- Research Directors (senior researchers), who have already gained research experience, recruited either from the group of junior researchers or from outside, and appointed by *ad hoc* juries composed following the same rules as for researchers, and chaired by the President of INRA or the Deputy Director General in charge of programmes.

Research departments propose the posts open to competitive entry. These proposals are reviewed by the Management Board, and then broken down between disciplines or groups of disciplines in line with the opinion of the Scientific Advisory Board, which also pronounces upon the transfer of posts from one competitive entry group if the results are partially or wholly unsuccessful because of a lack of appropriate candidates.

What is specific to France is the importance of the separate group of engineers, who in other contexts would be grouped with researchers, particularly since a significant number of them are recruited after completing a thesis. The posts are open to competitive entry after arbitration by the Management Board

⁸ These credits are little modulated between units, as variations in departmental support for units are ensured by incentive funding for projects. Nevertheless, a general orientation towards taking better account of evaluation results will lead to greater modulation.

⁹ Questions as to the attractiveness of public sector research and careers in science are now being raised in France, as they are in many other developed countries. The situation has worsened because of the scheduled retirement of numerous researchers over the next ten years (approximately 40% of all INRA staff will be affected).

of requests put forward by different departments.¹⁰ Engineers are also recruited by *ad hoc* juries.

Researchers (and engineers since 2003) all undergo four-yearly evaluations, which tend to be more advisory than punitive. Indeed, the careers of researchers are only loosely linked to these evaluations, except amongst the most junior researchers. Evaluations are performed by specialised, consultative scientific commissions with members from one or several disciplines, and they are appointed for four years. Promotions amongst Research Directors are ensured by *ad hoc* scientific panels chaired by the President of INRA or the Deputy Director-General responsible for programmes. Other elements of career development are organised on an administrative basis, and are not linked to scientific evaluation.

Alongside these full-tenure members of INRA staff and others with equivalent status from related research agencies and higher education, INRA also welcomes nearly 2,000 researchers (half of them being foreign researchers) to its laboratories who are appointed on fixed-term contracts. Nearly half of them are receiving doctoral or postdoctoral training. The others are taken on to carry out research contracts. All contribute to the scientific production of the Institute and to its international influence. Employment procedures are tending to become more similar to that in other European countries, particularly since the numbers are growing and could be even higher if organisational questions concerning European research careers were resolved.

INTERNATIONAL COMMITMENTS

International scientific cooperation is increasingly recognised as being of strategic importance because of the changing scientific, economic and social context of research that determines both new challenges and new objectives.

INRA has gradually adapted its strategic thinking and organisational structure to this new agricultural research environment. International cooperation is central to its orientation, since it strongly believes that agricultural research issues do not differ (or cannot be distinguished from) the general issues addressed in this respect throughout the world.

The first element that encourages a greater internationalisation of research activities is science itself. Contemporary agricultural research increasingly requires formal opportunities for international cooperation (creation of consortia or networks) as well as informal collaborative work between teams. The impetus is mainly coming from advances in methods and tools and the rapid adoption of such approaches by the entire scientific community; but it may also arise from the complex research topics that can be tackled using these new tools and the increasing levels of organisation involved in bringing together the necessary skills and resources. At a European level, the EU Framework Programmes,

¹⁰ In this case, as in the case of researcher recruitment, departmental demands result from arbitration within a department on requests received from research units.

aimed at implementing a European Research Area, have engendered a strong trend towards internationalisation which extends beyond *ad hoc* groupings of laboratories to include bilateral or multilateral cooperation, either focused on programmes or on the coordination of national programmes. INRA is participating in 129 European projects and is coordinating 21 of them; overall, these projects contribute 2.1% of the Institute's budget.

A second element, specific to agricultural research, is its international structuring aimed at furthering development, which has been facilitated by the international research centres of the Consultative Group on International Agricultural Research (CGIAR). Factors, which have contributed to an effective internationalisation of many research issues, include the changes that this network of 15 centres has undergone in recent years. Its links with research agencies in the most advanced countries and with research facilities in developing countries, the network's efforts to address more transversal issues despite the discipline-based expertise of individual members (the "Challenge Programmes") have expanded the limits of internationalisation. INRA aims to become more closely involved in this trend through its structured medium and long-term mobilisation on the research questions identified by these centres. This trend is also reflected in the evaluation of worldwide agricultural research and its links with development and perspective studies launched by the World Bank, the FAO and certain United National agencies (International Assessment of Agricultural Science and Technology for Development – IAASTD). INRA is closely involved in this assessment and has thus mobilised the French scientific community.

The third element giving impetus to the internationalisation of agricultural research is economic globalisation and, more broadly, exchanges between different societies. The latter corresponds to a globalisation of scientific challenges: many of the problems in the South have become or are now becoming problems for the North: emerging diseases, climate change, resource management, water management, sustainable development, etc.

In this new context, international scientific cooperation faces three types of challenge: scientific, strategic and cultural.

From a scientific point of view, the challenge of international scientific cooperation is the direct result of changes in the research context. Although, in many cases, assembling the necessary skills and financial resources can be achieved at a national level, there are more and more situations that call for international collaborative arrangements. These may be of a bilateral nature (INRA/BBSRC, INRA/USDA, INRA Agriculture Canada; INRA/Chinese Academy of Sciences, for example) or be multilateral: more or less formalised international networks (structural genomics, management of genetic or biological resources, forestry research, European Union programmes), or the coordination of international or national programmes.

Strategically, international scientific cooperation is an essential component in all decisions related to scientific policy: such choices can no longer be made without reference to the world context of the scientific field in question, the

agency's current position and more importantly, the position it wishes to attain and the alliances it needs to develop to accomplish its mission and achieve its objectives. Such alliances are essential to managing cooperation and competition, a science policy concern of particular importance. The choice of alliances does not depend solely upon scientific policy, to the extent that agricultural research forms part of agricultural policies that are founded upon, but also reach beyond, science policy. International scientific cooperation thus has a marked political dimension that cannot be ignored and that involves finding a dynamic balance at all times between the advantages of cooperation and the demands of competition.

The second strategic component of international cooperation is linked to the challenge posed by the shifting focuses of science. Opportunities must be sought for cooperation in countries that will play an important role in international science production in the future, both in order to control shifts in the centres of scientific research by linking their emergence to increased exchanges, and to harness new opportunities and talents. The collaborative projects developed by INRA with China, India, Brazil and countries around the Mediterranean basin are based on this principle, which is naturally reinforced when these same countries are agricultural powers (such as the first three in the list above). In such cases, economic challenges may also be linked to those of a scientific nature.

The renewed international focus on agriculture and food, and thus on agricultural research related to development processes and attaining the Millennium Goals, means that agricultural research agencies must rethink their role regarding the acquisition of knowledge and making it available for development purposes. This is not just a moral imperative; it is in all our best interests to share this knowledge.

Finally, international scientific cooperation involves a cultural challenge. Research is, by its very nature an integral part of culture, which implies that no human community can exist without it, even if it is the least privileged.

The aim of any type of cooperation, and this includes international scientific cooperation, is to create added value for all partners, even if these benefits are not the same for each partner taken separately. The primary criterion for evaluating cooperation is thus the benefits it will procure. This supposes an ability to evaluate this added value not only in terms of scientific advantages or costs, but also with respect to the creation of new skills, training, exploitation and the dissemination of knowledge, etc., all of which constitute objectives of international scientific cooperation. Appropriate evaluation techniques (*ex ante* and *ex post*) must be developed to provide sound foundations for international cooperation.

The second aim of cooperation relates to its strategic value, which usually implies a long-term, sustainable and organised commitment. International scientific cooperation can only achieve its strategic objectives and have a structuring effect if this action is underpinned by a shared determination to construct something new (a project, a network of laboratories, a scientific community) within a time frame appropriate to the size and scope of the joint project. It is indeed this trait, which sets international scientific cooperation (which is an

institutional responsibility devolving to the Management Board of INRA) apart from spontaneous exchanges between researchers or research teams. Although these can provide an excellent starting point for international scientific cooperation, global cooperation requires appropriately equipped, broader and complementary efforts, and firm foundations to achieve its ambitions.

Collaborative agreements based on those principles must also take into account the more and more difficult questions of intellectual property rights, access to genetic and biological resources, ethical rules.

Another sensitive aspect of international scientific cooperation concerns the reciprocal conditions for the hosting and circulation of researchers, and more generally the issue of international career paths for researchers.

THE EXPERT FUNCTION AND DECISION-MAKING SUPPORT FOR PUBLIC POLICIES

INRA's mission is also to provide expert advice to government authorities in support of its public policies. Expertise involves applying all available and relevant scientific knowledge in order to inform a question raised by an outside sponsor. In the past, this function was assumed in two ways. The first resulted from consultation of the Institute by government authorities concerning a particular question or element of public policy within INRA's area of competence (e.g. certain aspects of the Agricultural Orientation law). Secondly, different public or private sector bodies requested the individual opinions of a very large number of INRA researchers. In both cases, but to a more marked extent with professional structures, the expert participation of INRA researchers constituted a means of establishing links between research and its application, with numerous partners.

This situation has now changed. INRA has recently developed a collective scientific expertise function: a multidisciplinary group of researchers is entrusted with the task of informing a complex question raised by an outside sponsor, based on the current state of knowledge and aimed at highlighting the knowledge acquired to date, the uncertainties and controversies related to it and any deficiencies in the knowledge available. The Institute can now make a considerable contribution to decision-making in an uncertain environment.

One of the characteristics of INRA is that it bases its research on questions raised by society and the socio-economic environment in order to develop its research objectives. In this context, expertise is a good illustration of how scientists and the users of their research can interact. As a focus for the analysis and processing of questions raised by society, it allows researchers to broaden their views of a problem by situating it in the framework of the challenges it raises, while at the same time informing public decision-making thanks to an analysis of current knowledge and its consequences in terms of economic or social impact. Expertise also gives impetus for the initiation of new research programmes when major deficiencies have been identified. Expertise should therefore be considered as an important component in research activities.

The strategic importance given to expertise by INRA requires the improved professionalism of practices, the publication of Good Practice guidelines and procedures aimed at ensuring its quality, impartiality and transparency (declaration of interest), as well as recognition of these activities in the career path of a researcher.

ETHICAL QUESTIONS

The acceleration of advances in scientific and technical knowledge, the breadth of their current or future applications and, in parallel, the questions they raise, have changed the nature of the relationship between science and society.

Aware of the concerns of civilian society with respect to the benefits or risks of research applications, in 1998 INRA set up an Ethics and Precautionary Committee on the Application of Agricultural Research (COMEPRRA), comprising twelve independent, expert members from outside the Institute. The mission for this independent consultative body is to deliberate on the links between science and society in the areas of agriculture, diet and nutrition and the environment, and on the impact and ethical acceptability of the applications of agricultural research, so that it can formulate opinions and recommendations in this context.

Since it was set up, this Committee has emitted five opinions: on animal cloning, partnership, the patentability of living organisms, shellfish farming and plant GM organisms. It has initiated an in-depth review of expert activities, their importance and the appropriate conditions for their implementation. These opinions have been circulated widely both inside and outside the Institute, and discussion forums have demonstrated the importance of stringent ethical guidelines to informing public debate and providing researchers with reference points in their work. It should be emphasised that the aim of the COMEPRRA is not to reach firm decisions concerning controversial subjects, or to lay down standards, but, on the contrary, to provide the means for initiating debate.

CONCLUSION

Agricultural research management, in INRA as elsewhere, is under constraints, part of it being external, another part, probably more interesting and certainly more challenging, being internal.

On the external side, even if INRA's management is really free to organise science and to manage it in its own way under a four years contract with the government, as every institution funded by the general budget at this rate (85%) INRA is heavily dependent on the global situation of public finance and on the part devoted to research policy as a whole. It is also dependent of general rules concerning the status of civil servants, which are sometimes serious limits in human resources management (mobility, careers development for instance). In the last years, the attractiveness of research has decreased among students and this could lead to serious difficulties in recruitments in the future at a moment when all research institutions and universities are going to face massive retirements.

On the internal side, three main constraints can be pointed out.

The first one is the acceptance of change within the institution. INRA has been shaped to fit with its missions of the previous periods as described at the beginning of this chapter. That means that the evolution in scale and scope in the missions that is implementing requires a reshaping of the organisation and more broadly of the governance (see above). It needs long efforts to overcome the resistance as far as business as usual is easier than change. The difficulty is to find the best way and the right pace, fast enough to succeed, slow enough to convince.

The second one is the question of “over administration” (14% of the resources). This situation is partly linked to the choice made in the first thirty years to cover almost all the conditions in agricultural production in France in 200 sites. This choice is certainly no longer justified in the same terms as too costly and not aligned enough with new missions. On the other hand, it is also certainly one of the major forces of INRA in Europe and for the kind of research it wants to deliver. Once more the question is to find the right balance between keeping an experimental capacity, which is definitely a part of agricultural research and devoting more money directly to research.

The third one is the relationship between science and management. What is the part of science and scientists in the evolution of the institution? How to be sure that what is proposed and implemented will empower the scientists in the world competition? The answer to these questions is, at least partly, in the management process itself and in the way scientist are involved. It is also more than that: it rests on our capacity to merge the culture of research with the culture of management in order to actually share the need for evolution and the ways it has to take. It is more an ambition than a constraint.

ANNEX 1

INRA in brief

Strategic areas

Six strategic areas give structure to INRA's activities:

- Area A: ensuring sustainable management and improvement of the environment, controlling the impact of global changes and productive activities (21% of resources in 2006)
- Area B: improving human nutrition, preserving consumer health and understanding consumer behaviour (15% of resources, and increasing)
- Area C: diversifying products and their uses, improving their competitiveness (16% of resources, and diminishing)
- Area D: developing generic strategies for increasing knowledge in the life sciences (16% of resources)
- Area E: adapting species, practices and agricultural production systems (26% of resources)

- Area F: understanding and improving the organisation of actors and their strategies, analysing the challenges of public policies, contributing to their development and evaluation and anticipating change (6% of resources)

Budget

In 2006, INRA's budget reached €680.4 million, €577.3 million of which came from the French government and €103.1 million from dedicated income.

The budget for actions delegated by the National Research Agency should be added to the above. In 2005, this budget reached €47 million.

Human resources

INRA staff can be broken down as follows:

- 1,845 researchers, 1,580 engineers, 5,130 research assistants, technicians and administrative staff, all paid by INRA and benefiting from civil servant status (of whom 47.7% are women),
- 1,000 researchers from other research agencies and universities,
- 1,200 researchers on short-term contracts,
- 700 foreign doctoral or postdoctoral researchers.

General organisation

14 Research Departments grouping 260 Research Units, 60% of which are run in partnership with other research or higher education institutions.

21 Centres spread throughout France (both mainland and overseas).

Principal results

2,917 scientific publications in 2005, 1,540 published jointly with teams in other countries (1,003 joint publications with teams in the European Union, 537 with the rest of the world).

170 contracts each year with private companies

205 patents and 250 active licensing contracts.

ANNEX 2

List of research departments

Animal Genetics Department

Animal Health Department

Applied Mathematics and Informatics Department

Department for Science and Process Engineering of Agricultural Products

Department of Animal Physiology and Livestock Systems

Department of Forest, Grassland and Freshwater Ecology

Department of Social Sciences, Agriculture and Food, Environment and Space

Environment and Agronomy Department

Food and Human Nutrition Department
Microbiology and the Food Chain Department
Plant Biology Department
Plant Breeding and Genetics Department
Plant Health and the Environment Department
Science for Action and Sustainable Development Department

CHAPTER 16

THE INDIAN AGRICULTURAL RESEARCH SYSTEM

M.S. SWAMINATHAN AND S. BALA RAVI

*M.S. Swaminathan Research Foundation, Third Cross Road, Institutional Area, Taramani,
Chennai 600 113, India*

HISTORICAL

Today India has one of the largest agricultural research systems in the world. The history of Indian agricultural research system is traceable back to more than 12 decades. The earliest event related to agricultural research in India was the establishment of Departments of Agriculture in each Indian Province in 1880 under the British rule. This was based on the recommendations of the Famine Commissions. An appointment of the first agricultural scientific staff under the Central government was made in 1887. The early agricultural research system evolved very slowly with the establishment of research institutions such as the Imperial Bacteriological Laboratory (which later became Indian Veterinary Research Institute) in 1889, the Imperial Agricultural Research Institute (which later became Indian Agricultural Research Institute) in 1905, and the Imperial Institute of Animal Husbandry and Dairying (which later became National Dairy Research Institute) in 1923. All these institutions were administered by the Department of Revenue, Agriculture and Commerce of the Government of India. Lord Curson, for the first time in 1905, set apart a separate budget of Rs 2 million to assist agricultural research, demonstration and education in the Provinces. Two historical events having far-reaching impact on Indian agricultural research system were the Montague–Chelmsford Reform and the founding of the Imperial Council of Agricultural Research (ICAR). The Montague–Chelmsford Reform in 1919 vested all powers of superintendence, direction and control of agriculture and animal husbandry with the Provincial governments, while the Central government retained the administration of agricultural research and educational institutions.

The Royal Commission on Agriculture (RCA) appointed in 1927 commented in its report: “In a country with such a long history, little surprise need be felt that system of tillage based on experience should have reached a stage beyond which further progress was bound to await scientific discovery. The cultivator

in the main met new demands by breaking up new areas rather than by intensification of method. For further progress, he requires all help which science can afford and which organization, education and training can bring within his reach" (RCA, 1928). On recognizing the need for a central agency to promote, guide and coordinate agricultural research across the Provinces the RCA recommended establishment of the ICAR. The ICAR came into existence in 1929 under the department of Agriculture and was entrusted with the administration of a non-lapsing fund of Rs 5 million with mandate to assist provincial research. The research system at the Provincial level was largely conducted under the respective departments of Agriculture and Animal Husbandry through the agricultural and veterinary colleges. This led to a co-evolution of research and education (R&E) in Indian agriculture. Notable institutions under Provinces were the Sugarcane Breeding Station (which later became Sugarcane Breeding Institute) founded in 1912 and the Rice Research Station founded in 1911.

Pre-Independent India's research and development (R&D) ran by the Central Department of Agriculture placed priority on commercial crops. This resulted in the establishment of semi-autonomous commodity committees on cotton, lac (*Laccifer lacca*), jute, sugarcane, coconut, tobacco, oilseeds, areca nut, and spices and cashew nut. Under these Committees, which were under the control of the Central department of Agriculture, research institutions such as the Cotton Technology Research Laboratory at Bombay, Indian Lac Research Institute at Ranchi, Jute Agricultural Research Laboratory at Dacca (moved to Kolkata in 1947), Coconut Research Stations at Kayankulam and Kasaragod, Indian Institute of Sugarcane Research at Lucknow, and the Central Tobacco Research Institute at Rajahmundry were established. ICAR had no role in coordinating the research performed under these committees.

Independent India in its Constitution adopted in 1950, placed agriculture as a State subject. It, however, placed under the responsibility of the Central government the scientific or technical education financed by it wholly or partly, those institutions of national importance declared by the Parliament by law, coordination of research in scientific and technical institutions and determination of standards in institutions for higher education. Thus, both the States and Centre are responsible for agricultural R&E with the role of coordination of higher education and scientific research vested with the Centre. In conformity with the Indian Constitution, the ICAR, which was renamed after independence as the Indian Council of Agricultural Research, was made the apex national organization to plan, conduct and promote research, education, training and transfer of technology for advancement of Indian agriculture. ICAR continued to be controlled by the Department of Agriculture.

However, agriculture continued to be treated as a subject for generalist rather than the specialist. Therefore, research policies were frequently formulated at the administrative and political level rather than at the scientific level. This led to strict compartmentalization of different scientific disciplines and functioning of these disciplines in parallel lines with convergence only at administrative focal

point. Unfortunately, during the early years of independence, the Government of India did not conceive agricultural research as a potent tool for achieving rapid economic advance and this is evident from the Scientific Policy Resolution adopted in 1958. This Resolution states, “The wealth and prosperity of a nation depend on the effective utilization of human and material resources through industrialization. . . .” “We now know that had only the words “agricultural development” been added to the Resolution along with “industrialization”, the hopes expressed could have at least partially become true. It is this lack of appreciation of the pivotal role of agricultural research in harnessing the advantageous features of our biological endowment that probably led to the indifference of the Government in improving the administration of agricultural research” (Swaminathan, 1968).

In 1963 an Agricultural Research Review Team headed by Dr. M. W. Parker of the USDA examined the organizational structure to bring the best out of the investment, to promote greater Centre–State coordination, evolve research strategy to achieve sustained and substantial production improvement, and to establish an effective two-way channel between farmer and research institution. The recommendations of this Committee (1964) led to the reorganization and reforming of Indian agricultural research system in 1966 with improved working conditions for research, better equipped research centres with teams of research specialists, coordination in research activities, and improving use of research outputs. The commodity committees were dismantled and ICAR took over full control over all central research institutes, including those established by the commodity committees and under the Department of Agriculture (Randhawa, 1979). Similarly, at the State level agricultural R&E were shifted from the control of respective Department of Agriculture to the concerned agricultural universities. With respect to agricultural education, ICAR was given the status as the national apex body in agricultural education equivalent to what University Grant Commission (UGC) is to general education. The National Agricultural Research System (NARS) also has a growing private sector research as an important component, which includes a small, but significant role from non-profit seeking institutions. Thus, a framework for NARS devised with the reorganization of the ICAR in 1966 grew into one of the big research systems in agriculture in the world (Fig. 1).

DETERMINATION OF RESEARCH PRIORITIES

When India became independent, her strength in agricultural research, particularly in the foodgrain sector was weak and faced daunting challenges in feeding the nation. Although the political priority to agriculture is obvious from the statement of the first Prime Minister of India, Jawaharlal Nehru, in 1948, “everything else can wait but not agriculture”, there was less research priority for more than a decade on improving the productivity of food crops through variety improvement pathway. The coverage of high-yielding varieties in food

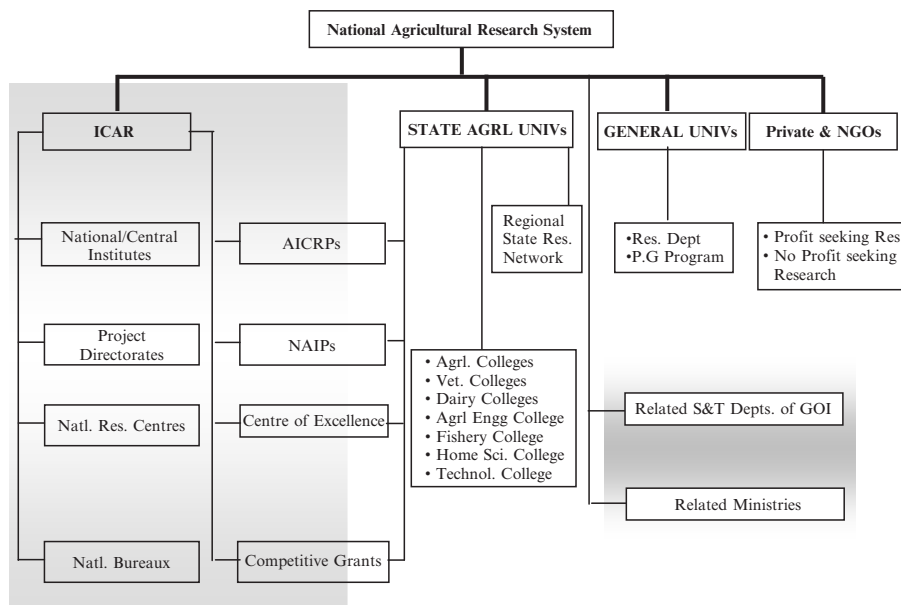

Figure 1. Organogram of National Agricultural Research System of India (adapted from Raman et al. 1988). [The institutions within the shaded box are directly under the administration of Government of India (GOI)]

crops was less than 5%, while in many other crops except sugarcane, cotton and jute there were little alternative to traditional varieties and low-yielding populations maintained by farmers. The food production and its growth were far below the requirement of a large and rising population. Indian agriculture was still a “gamble with monsoon”. An acute food shortage passed on to the Independent India was increasing rapidly. India imported 1.5 m t foodgrains in 1946, 2 m t in 1947, 3 m t in 1948, 4.5 m t in 1949, and 4.8 m t in 1950. This continued with increasing imports every subsequent year and peaked in 1966 with 10.4 m t. In addition, the country lacked capacity to pay for the import bill either in foreign exchange or national currency. The young nation lived in shame and humiliation heaped upon it with identity like “begging bowl”, “starving millions” and “ship-to-mouth nation”. The authors of the book *Famine 1975!* (Paddock and Paddock, 1965) predicted Indians would die in their millions by 1975 and none can save them. India had a very bad time and this took her to the Title I of the US Public Law 480 offered under Food Aid by the USA (USDA, 2003).

Variety improvement of food crops naturally became the first priority for Indian agricultural research during the 1960s. In the case of rice, which occupied about 37% of the cereal crop area in the 1950s, there was effort to breed high-yielding varieties combining fertilizer-response character through *indica-japonica* hybridization programme. Subsequently, during the early 1960s

tropical *japonica* varieties such as Taichung 65, Taichung Native-1 and Tainan-3 from Taiwan were introduced and used in crosses to breed Indian *indica* rice with fertilizer-responsiveness and high yield. During this period, improvement of Indian tall wheat by pure line selection and crosses achieved modest yield increase. There was also an increased stress on millets, which in the 1950s occupied almost 50% of the area under cereal crops, to increase their yield. An Accelerated Millet Improvement Scheme was launched in 1961 to breed and test millet hybrids under a network programme. Help also came from the US government to support Indian agriculture with experts, advices and projects. Rockefeller Foundation helped in millet improvement with supply of parental stocks of maize from Mexico and sorghum and pearl millet from the USA. Ford Foundation assisted the Intensive Agricultural Development Programme (IADP) of the government, which was a transfer of technology package to increase essentially the productivity of grain crops in farmers' fields.

Variety improvement programmes took the driving seat of Indian crop research with the arrival of fertilizer-responsive dwarf Spring Wheat from the International Centre for Maize and Wheat Improvement (CIMMYT) in Mexico and similar dwarf *indica* rice from the International Rice Research Institute (IRRI), the Philippines during early and mid-1960s. This was the trigger to the Indian Green Revolution. With the arrival of high-yielding dwarf germplasm in rice and wheat and "indigenization" of cytoplasmic male sterility (CMS) and fertility restorer systems in millets, an intensive breeding effort was mounted at national level with the help of All India Coordinated Research Projects (AICRP) in each of these crops. The AICRP is a unique instrument for achieving inter-institutional and interdisciplinary integration in research work, without causing any "administrative disturbances" (Swaminathan, 1968). In the case of crops, AICRP is led by variety improvement. This research prioritization and massive efforts continuously increased productivity and production, which was unparalleled in the case of wheat, and this took the country to a turning point with food sufficiency in less than a decade (Swaminathan, 1993). By 1975, which was the year predicted for the death of millions of Indians out of starvation (Paddock and Paddock, 1965), Indian agriculture turned the country famine-free and to food self-reliance.

There was considerable self-learning on national and regional prioritization on research and fund deployment from the policy-research-adoption processes associated with breakthroughs in foodgrain production. In general, the ICAR and the Indian Planning Commission with the approval of Indian Parliament jointly decide the national research priorities on agriculture. Governing Body, which the Director General of the ICAR heads, is the chief executive and decision-making authority in ICAR. It consists of eminent agricultural scientists, educators, legislators and representatives of farmers. It is assisted by the Standing Finance Committee, Accreditation Board, Regional Committees and several Scientific Panels (Fig. 2).

The Planning Commission on the basis of priorities determines the resources to be mobilized to each area, sector and down to the level of ICAR institutes

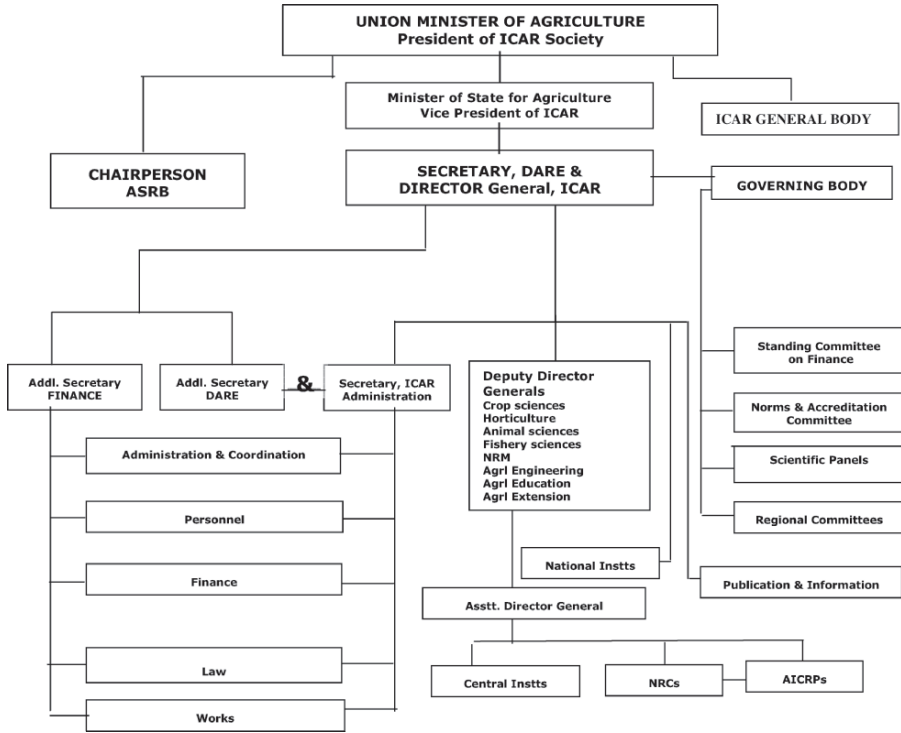

Figure 2. Organogram of the Indian Council of Agricultural Research (adapted from Raman et al. 1988).

and State Agricultural Universities (SAUs). This national priority is then decomposed into sectoral and regional priorities with proportionate fund deployment for administration and coordination of the research efforts in a multidisciplinary mode across several institutions, largely under NARS. Each of these institutions assigns its research priority in sync with the national and regional priorities and funding. Although these institutes have defined role and responsibility as their mandate, this is flexible to absorb the periodically determined national priorities in their domain. At the bottom level research priority is decomposed into research projects, involving interdisciplinary intra-institutional or often inter-institutional collaboration. These projects are developed by identified groups of scientist who have expertise in the area.

Under the ICAR, the project development, review and approval at institutional level follow different patterns depending on the source of funding. The funding source can be internal (institutional) and external. The external can be the competitive funding from the ICAR or from non-ICAR institutions, including national and international agencies. Virtually there is no funding from private sector to ICAR or SAUs for supporting research. The framework

for development, approval, management and evaluation of projects internally funded is defined under the project management system of the Agricultural Research Service (ARS) established in 1975. The reorganized project management system under ARS requires each institute, depending on its scientific strength and institutional structure, to establish Research Advisory Committee (RAC) and Staff Research Council (SRC) with scientific experts drafted from outside. RAC is for larger institutes having disciplinary divisional set-up and SRC is for smaller institutes like NRCs where there is no divisional set-up. RAC apart from external experts may include a few senior scientists of the institute. In the case of SRC, all scientists of the institute are made its members, apart from external experts. There is no representation of farmers or industry in both RAC and SRC. However, farmer representatives are included in the Management Committee (MC) of each institute, which oversees all its R&D activities. The RAC/SRC is required to meet and transact business with specified periodicity. The system has also prescribed specific format for project proposal (RPF I), for annual progress reporting on the project (RPF II) and for the project conclusion report (RPF III). Newly developed project is required to be presented before the RAC or SRC for its review and approval. Records of all transactions in RAC/SRC are required to be maintained by the institute.

Similar systems, but not identical exist in SAUs. However, there is considerable variation across the SAUs in the process of project development, approval and its periodic review.

In the case of projects funded from outside the institute, by competitive grants including from ICAR, the project development procedure and format of project may largely be prescribed by each of the funding agencies. The competitive project grant provided by ICAR prescribes a format different from RPF I. Depending on the source of funding, it may either start with a concept note on the project or with the project proposal itself. In all cases the proposals are reviewed and approved by a group of external experts both at concept and full project stages. Under programmes like National Agricultural Innovation Project (NAIP), projects are initially approved on the basis of concept note and full-fledged projects based on approved concept are further short-listed for personal presentation and discussion with the peer groups by the project scientists. These projects are approved after three phases of screening. Expert committees annually make the progress reviews on these projects. About 12% of the ICAR research budget is made available for competitive funding of projects within and outside NARS (Pal and Byerlee, 2003).

In the case of projects funded by agencies other than ICAR, such projects are developed in accordance with the guidelines of the funding agency. Project proposals for funding from non-ICAR organizations within India take two routes for ICAR institutes and SAUs. ICAR institutes have to submit such projects through its headquarters, while SAUs may submit such proposals directly to the funding institution. In the case of all projects originating from NARS seeking funding from outside India, they have to be forwarded through

the concerned administrative set-up for approval in respect of project objectives, its compatibility with the mandate of the institute where the project is to be executed and the ICAR policy on such external funded research and national sensitivity aspects, if any.

INSTITUTIONAL SYSTEM FOR DEVELOPMENT, APPROVAL AND MANAGEMENT OF RESEARCH PROJECT

The institutional research projects described in RPF I and moving through the RAC/SRC route will have clearly defined objectives and justification for undertaking the project. It will also have a review on the state of the prior art, activities and the timeframe proposed for achieving the objectives and the role of different scientific partners or institutions, when the project is inter-institutional. Other information to be provided in the RPF I is the additional infrastructure and human resources required and the financial resource required under different budget sub-heads. Important project events leading to the objectives are divided into few perceivable milestones for the purpose of internal and external monitoring and activity coordination within the project team. As resources are always a constraint, the technical administration at the ICAR together with the Institute Management Committee determines the priority and core area projects of the institute for prioritized resource mobilization and allocation. Research projects are approved in the RAC/SRC, which is required to take collective decision on scientific matters with the help of external expert members. However, the Chairperson of the RAC/SRC, who always is the concerned institute director, exerts an important role in approval, modification and rejection of projects. Regular report on work progress of projects approved and implementation started is required to be presented at the SRC or RAC either by the project leader or both by the leader and the sub-programme leaders at six-monthly interval. Such reporting may also extend to field or laboratory visit to witness the progress.

Each project scientist is mandated to provide a summary of progress achieved in each project he/she is involved in RPF II, once a year at a specified time. This is maintained by the administration along with RPF I as the project file of each scientist for the purpose of monitoring the research progress and evaluating his/her work during annual and five-yearly assessments for career advancement. Thus, there is an accountability component linked between the scientist and project, which is discussed later. In addition, project results are appropriately reported in the annual report of the institute as a mandatory requirement. Scientists have freedom to publish results in professional journals according to their judgement on the adequacy of results and desirability for doing so. In recent days, with increasing importance being given to intellectual property rights, scientists are encouraged to establish such rights, wherever scope exists, before going for publication. Presentation of results in professional conferences or seminars is also left to the choice of scientists. These publication rights are

restricted when the project results have a sensitivity angle, which is however very rare in agriculture. The RAC/SRC system also allows scientists to effect any mid-course correction to the project, on substantiated and justified grounds. A recent ICAR review committee headed by Dr. R.A. Mashelkar had recommended that the RAC/SRC should be accorded due primacy in managing the scientific portfolio of the institute and the SRC needs to be treated as the backbone of performance appraisal system both in respect of the individual scientist as well as the institution (Anonymous, 2005a).

RESEARCH ADMINISTRATION AND MANAGEMENT

The overall programme on each sector of agricultural research is finalized at the higher hierarchy of the ICAR. The technical portfolio of the ICAR is divided into eight disciplinary divisions. These are Crop Sciences, Horticulture, Animal Sciences, Fishery Sciences, Natural Resource Management (NRM), Agricultural Education, Agricultural Engineering and Agricultural Extension. A Deputy Director General (DDG) heads each of these divisions. The DDG is assisted by a few Assistant Directors General (ADGs) and scientists (Fig. 2). Each of these divisions will be implementing its programmes largely through the institutes and projects belonging to their discipline. These divisions together administer 95 institutes and 99 networked projects including 84 All India Coordinated Research Projects (AICRPs) as shown in Figure 3. These divisions are responsible for the shared ICAR mandate on research, education and technology transfer and their budget is allocated on the basis of internally determined priority. Each of these divisions on their own prioritize the programme consistent with the national and ICAR priority and reassign the task to the

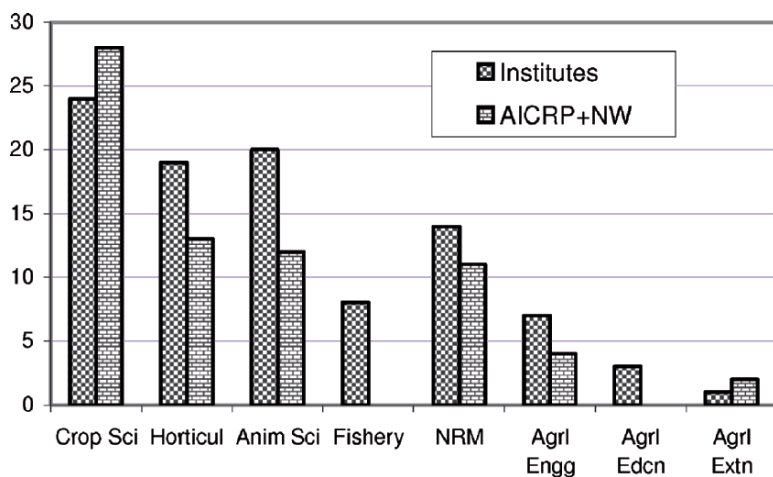

Figure 3. Number of institutes and coordinated research programmes under each division of the ICAR. (see Color Plate 10 following p. xviii.)

institutes and AICRPs under their control. At the institute level the projects are identified and executed as explained earlier. Each AICRP usually operates on single theme having regional and/or national importance in enhancing farm productivity, farmer income, resource management, etc. These coordinated programmes are determined on need basis and developed by the concerned division providing defined objectives, regions for project implementation and details on the disciplines and institutions to be engaged under the programme along with their roles. All such new research programmes are implemented only with the approval of its Governing Body. The institutions commonly involved are the relevant ICAR institute(s) under the concerned division and SAUs having mandate in the region with less frequent private institutional participation. The project has inherent strength in speeding up the testing and transferring of technologies and to create functional linkage among the institutions and the scientists working on related problems across NARS and private sector. An important element of this project is the decentralized and participatory process involving all networked partners in goal setting, developing work plan, reviewing progress and outcome and identifying and recommending proven technologies for farmer adoption.

At each institute level, research administration is largely based on the project system although a significant part of the activities and funding flow to non-project based programmes. There is considerable centralization of authority with the institute management represented as the institute director. This power structure determines allocation of resources across disciplines, research projects, expansion of research infrastructure and activities, and associated personnel deployment. This centralization of authority creates an unhealthy alliance with administration encouraging transfer of power to administration and bureaucratic practices. The scientists who are responsible for project implementation and being held accountable for project outcome are left totally at the discretionary use of the centralized authority (Bala Ravi, 1989). While different ICAR Review Committees had recommended delegation of administrative and financial powers to project leaders and research scientists for speedy implementation of research work, it remains unimplemented until now. This is again echoed in the most recent recommendations of the Mashelkar Committee on reorganizing ICAR. It recommended, "The entire research portfolio of the institute should be projectized. The project leader/principal investigator should have the full financial powers for procurement of items listed in the approved project document, for which funds are available in the project budget during the year" (Anonymous, 2005a).

INSTITUTIONAL ORGANIZATION TO SUPPORT RESEARCH SYSTEM

The ICAR currently has 95 research institutions, including National Institutes for basic and strategic research and postgraduate education, Central institutes and Project Directorates for commodity-specific research,

National Bureaus for conservation and exchange of plant, animal fish and agriculturally useful microbial germplasm and on soil survey and National Research Centres (NRCs) for conducting applied commodity and system-specific strategic research (Fig. 4) (ICAR, 2006). These institutes, on the basis of their mandates, fall under eight technical disciplines of the ICAR as described earlier (Fig. 2). Among these institutes four have pre-eminent national status with role in R&E and enjoying the Deemed University (DU) status. Each of them is larger in disciplinary specialization and scientific strength. For example, Indian Agricultural Research Institute, which is one of these four, has five major schools including a school of basic sciences and 28 divisions/departments for research on many areas of specialization. Similar extensive and multidisciplinary research in animal, dairy and fishery sciences is being conducted respectively in the Indian Veterinary Research Institute, National Dairy Research Institute and the Central Institute of Fisheries Education. Many of the Central institutes and National Research Centres are devoted to specific field or horticultural crops, specific live-stock species, and specific fishery system. Some others are engaged in production systems, natural resource systems, agro-forestry, areas of agricultural engineering, post-harvest processing, etc. There are also few institutions on social science such as women in agriculture and agricultural economics and policy research. The National Bureaus on crop, animal, fishery and agriculturally useful microorganism undertake conservation, characterization, database development and bilateral or multilateral exchange of this diversity. The National Bureau of Soil Survey and Land Use Planning is engaged in soil survey including resource mapping at national, State and district level for land use planning.

The administrative structure of most of these institutions is more or less similar with differences arising due to the variations in the size of the institution. Directors head all institutes. All of them, except the NRCs, have variable number of disciplinary divisions, with the management of each division assigned to a Head of Division. NRCs are relatively smaller institutions with no disciplinary divisions, although their research programmes are multidisciplinary in nature. Both the Director and Heads of Divisions are selected and appointed for tenure of five years, with eligibility for performance-based extension for one more

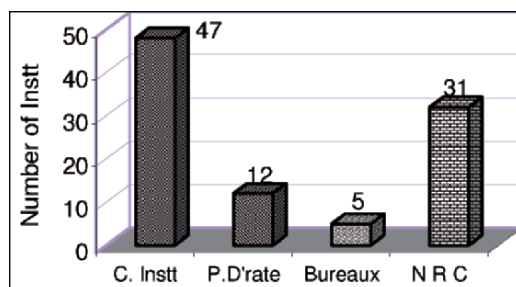

Figure 4. Profile of the research and educational institutes under the ICAR. (see Color Plate 11 following p. xviii.)

equal term. Scientists under each division, depending on the size, are either organized into many or few teams having common research activity area. Many scientists often work in more than one project and also programme area.

In addition, the ICAR supports frontline extension systems such as frontline demonstrations, technology and *Krishi Vigyan Kendras* (KVKs). The KVK is the grass-root level training institutions designed to provide formal and informal training on appropriate farm technologies to village level workers, including non-governmental organizations and the farmers. Currently there are 496 KVKs and one KVK in each of the 527 districts of India is expected to come into existence by the end of 2007.

With many diverse practices in crop–animal–fish production appropriate to the several agro-climatic regions falling under different States of India, the agricultural R&E system under these States have the responsibility for location specific technology development, transfer and administration of agriculture. The establishment of SAUs and entrusting them with the responsibility for R&E is a major step in removing the administrative constraints hurdling the research output. The first SAU, Govind Ballabh Pant University of Agriculture and Technology, was established in *tarai* region in 1961, now in the State of Uttaranchal. Following this, six more SAUs were established in the States of Punjab (Ludhiana), Rajasthan (Udaipur), Madhya Pradesh (Jabalpur), Andhra Pradesh (Hyderabad), Karnataka (Bangalore) and Orissa (Bubaneswar). By 1966, there were eight SAUs and two DUs in nine States. Sir Joseph Hatchinson of Cambridge University commented: “The most significant development in the field of Indian agriculture during the past hundred years prior to 1967 is the initiation of Agricultural Universities.” This enormously strengthened human resource development required for agricultural research, teaching and technology transfer. Establishment of SAUs gained further momentum after 1966 with the reorganization of ICAR and its emergence as the national apex body in agricultural education equivalent to what UGC is to general education (Fig. 5). Currently there are 39 SAUs, five DUs and one Central University (CU) (ICAR web site).

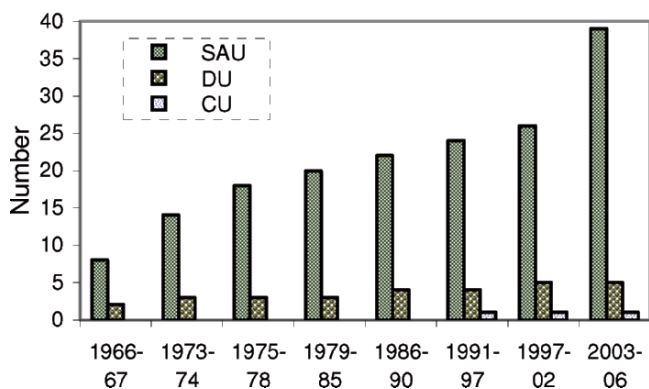

Figure 5. Growth of State Agricultural Universities, Deemed Universities and Central Universities in India. (see Color Plate 12 following p. xviii.)

FUNDING OF AGRICULTURAL RESEARCH AT NATIONAL AND INSTITUTIONAL LEVELS

According to the data available until 2000, 37% of the national expenditure on agricultural R&E is accounted by all ICAR institutes, 51% by the SAUs, and the remaining 12% accounted by other public and private organizations. The funding largely comes from four important sources. The first source is the central government, which provides 52% and almost this entire fund passes through the ICAR. During 2004–2005, the ICAR spending on R&E is reported to be Rs 34.28 billion (DARE, 2006). Nearly 30% of this fund is shared with other research partners under NARS, mainly the SAUs, with small amounts going to public research institutions outside the NARS and to profit seeking and non-profit seeking private research organizations (Fig. 1). About 30% of this extramural funding from ICAR is made through the AICRPs in the form of block grants, 12% through competitive funding schemes, 17% through grant to district outreach centres, the KVKs, and the rest as donor-funded and development grants to SAUs (Pal and Byerlee, 2003).

The second major source of funding is annual block grants from the State governments to the SAUs, which accounts for about 43% of all research funds. In 2000, ICAR received about 5% of its total budget from two other sources, namely, 2% from the Agricultural Produce (AP) Cess Fund (a levy at 0.5%, *ad valorem*, on specified export commodities) and 3% from internal resource generation (Pal and Byerlee, 2003). On an average about 3% of the funding to NARS is sourced from few donor agencies. The two largest donors are the USAID until 1990 and the World Bank since 1980. The total contribution of World Bank is about \$646 million, while that from the USAID is about \$108 million (\$ represents 1999 PPP, which is US\$ normalized to 1999 Purchasing Power Parity; all \$ expressions hereafter, including in tables are US\$ PPP, unless otherwise specified). The size of private research funding in Indian agricultural research is estimated to be equal to about 11% of the public funding.

In real terms, total funding for agricultural R&E over the last four decades increased (1999 prices) from Rs 2.46 billion (\$284 million) in 1961 to Rs 7.57 billion (\$875 million) in 1981, and then to Rs 25.0 billion (\$2,893 million) in 2000 (Fig. 6). This represents a tenfold increase across 40 years (Pal et al. 2005). An increasing trend was observed for both Central and State funding. The Central funding outpaced State funding during the 1970s, both reached neck and neck during and after the 1980s (Fig. 7). Overall, 48% of all public R&E resources are allocated to research, 19% and 33% are allocated to teaching and extension, respectively (NFC, 2006). In absolute terms research expenditure is Rs 16.2 billion (\$1,898 million) in 2000. Overall public research funding grew at 3.16% in the 1970s, 7.03% in the 1980s, and slowed to 4.61% in the 1990s (Pal and Byerlee, 2003).

National priority is discernible from the sectoral allocation with crop sciences receiving major share (66.5%), followed by livestock (27.9%), fishery (3.03%) and agro-forestry (2.51%) (Ranjitha and Mruthyunjaya, 2005). Crop sciences also engaged predominant share of scientific personnel in the ICAR and SAUs

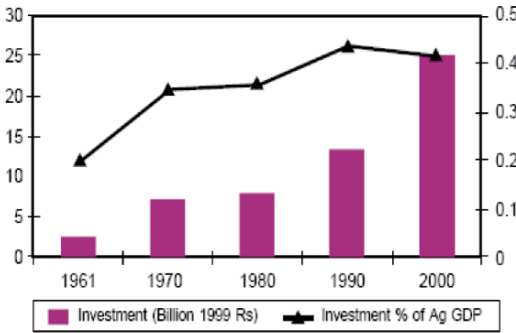

Source: Pal, Mathur and Jha, 2005

Figure 6. Funding to Agricultural Research and Education in India during last four decades. (see Color Plate 13 following p. xix.)

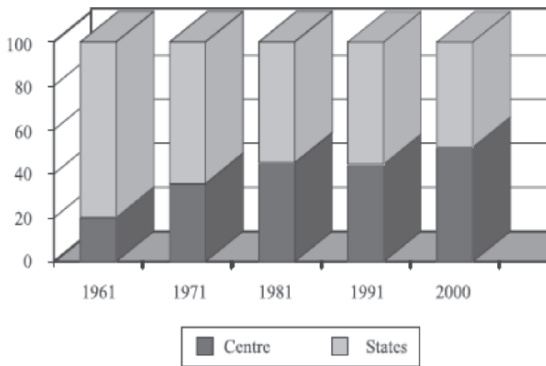

Figure 7. Relative Agricultural R & E funding by the Center and the State governments.

Source: Pal et al., 2005.

(Desai, 1989). The recent scientific deployment status shows 37% in food crops, 30% on non-food crops, 18% in livestock, 12% in fishery and 3% in other sectors (ICAR, 2006). Another study (Jha et. al., 1995) shows that a major share of agricultural research is crop-focused. Foodgrains and horticultural crops, the mainstay of the national food system, account for above 40% with the other major groups, livestock and fisheries together receiving around 22% (Fig. 8). Food security still remains a strategic concern and claims very high priority. While the ICAR allocation to livestock and fish is 25%, the SAU allocation to these sectors is about 19%. This study also pointed out that agricultural extension is given unduly high allocation of resources, while other disciplines like education and research in horticultural and livestock areas did not receive funding commensurate with their economic significance and expected contribution to equity, sustainability and exports. Thus, different studies on sectoral allocation of funding indicate imbalances in internal priority determination and fund deployment by the ICAR and SAUs.

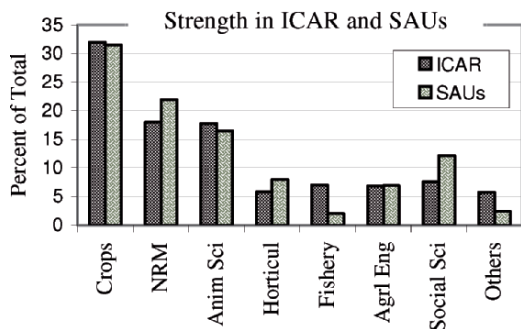

Figure 8. Discipline-wise scientific strength in ICAR and SAUs.

The public funding largely supports the Indian NARS, which is one of the largest research systems in the world. This funding is far lower when seen in percentage of Agricultural Gross Domestic Product (AgGDP) and in comparison with investment in many developing countries and of all developed countries (Table 1). During the late 1990s, the Indian funding to agricultural research was 0.34% of AgGDP. This is lower than that of China (0.40%) and far below the average of all developing countries (0.53%) and less than one-seventh of the average for all developed countries (2.36%) (Pray, 2000). In AgGDP terms, the level of funding by the States is also equally low, with an average of 0.28% during 2002–2004 and a huge variation across States ranging from 0.08% to 1.37% (Table 2). This obviously impacts on the investment per scientist in the States, which varied from 0.59 million in Uttar Pradesh to 1.4 million in Maharashtra. When the overall national research expenditure is matched with the number of scientists in NARS, it emerges that the fund available per scientist annually in India is \$17,500, which is mere one-twelfth of the fund available in USA (\$213,000) and Japan (\$203,000). The explained variation in R&E investment across SAUs is also reflected in the deployment of funds across major agricultural research administrative regions within the country. A study by Evenson et al. (1999) brought out that the agricultural R&E fund deployed during 1985–1990 across the five zones of the country

Table 1. Expenditure on agricultural research in India and other regions in 2000 (Pray, 2002)

Country/Group	Total spending (million \$, 1999 PPP)	Intensity (% of AgGDP)
India	1,858	0.34
China	3,150	0.40
Brazil	1,020	1.81
Japan	1,658	3.62
USA	3,828	2.65
All developing countries	12,819	0.53
All developed countries	10,191	2.36

Table 2. Growth and intensity of agricultural R&E funding by the States of India (Pardey et al., 2006)

States	Annual compound growth rate (%)		Funding as share of AgGDP (%)		Funding/scientist (Rs million)	Share in funding by all States (%)
	1982–91	1992–04	1981–83	2002–04	2002–04	2002–04
Andhra Pradesh	6.47	5.48	0.16	0.24	1.00	7.69
Assam	5.51	4.08	0.28	0.39	0.79	3.41
Bihar*	8.55	4.25	0.13	0.23	1.36	4.50
Gujarat	9.71	6.4	0.19	0.54	1.21	7.29
Haryana	5.16	6.68	0.28	0.42	0.87	5.67
Himachal Pradesh	12.76	–	0.62	1.37	0.80	3.61
Jammu & Kashmir	10.97	12.19	–	0.92	0.99	2.79
Karnataka	7.54	6.27	0.19	0.42	0.71	7.27
Kerala	5.23	2.79	0.31	0.52	1.26	4.88
Madhya Pradesh*	13.29	8.8	0.07	0.21	0.76	4.80
Maharashtra	7.06	6.26	0.39	0.59	1.40	16.23
Orissa	6.50	2.17	0.10	0.15	0.80	1.59
Punjab	10.28	5.12	0.24	0.31	0.77	6.57
Rajasthan	10.95	5.22	0.12	0.24	0.74	4.16
Tamil Nadu	13.00	5.59	0.21	0.51	0.95	8.04
Uttar Pradesh*	5.74	–6.56	0.13	0.08	0.59	4.21
West Bengal	2.34	7.45	0.17	0.12	1.33	3.96
All States	8.23	5.64	0.19	0.28	0.84	100.00

* For undivided State of Bihar, which now includes Bihar and Jharkhand; and Madhya Pradesh, which now includes Madhya Pradesh and Chathisgarh.

in terms of the percentage of AgGDP is: Central zone, 0.26%; North zone, 0.71%; South zone, 0.35%; West zone, 0.29%; and East zone, 0.15%.

Total private funding for agricultural research (including funding by State-owned enterprises) in India doubled from Rs 800 million (\$26 million) in 1985 to Rs 1,695 million (\$56 million) in 1995 (Table 3) (Pray, 2002). In 2000 private investment was 11% of total agricultural research funding. Private research funding had been growing at 7.7% annually compared to 5.1% in the public sector during 1985–2000. A comparison of private investment in agricultural research in India with the same in rest of Asia presented in Table 3 (Pray, 2002) shows the private investment in terms of total investment and annual growth rate is better in India.

The funding within ICAR and SAUs is based on multiple criteria such as the relative priority of each sector in tune with the short- and medium-term national or State goals, number of sub-sectors or institutes within each of them, the number of staff, the infrastructure, the research projects and technology transfer programmes underway in each institute, and the track record of the sector and institute in effective utilization of the fund. Normally, the past funding has important bearing on subsequent funding. Within institutes,

Table 3. Growth of private research in India and rest of Asia (Pray, 2002)

Country	Expenditure (million \$ 1995 PPP)		Annual growth rate (%)	Private as% of total, 1995
	1985	1995		
India	26	56	7.7	13.9
China	0	16	—	3.2
Indonesia	3	6	6.9	6.9
Malaysia	14	17	1.9	21.0
Philippines	6	11	6.1	22.4
Thailand	11	17	4.4	11.8
Pakistan	2	6	11.0	Na
Total	62	128	7.2	10.1

project-based funding is largely followed after accounting for institutional common overheads. The share of institutional overheads and the funds available for supporting research varies widely across institutions, with least funds for supporting research in many SAUs. Competitive projects are encouraged in many institutions and there is an increasing share from this source in research funding. However, major sources for competitive grants are ICAR itself and other Central government departments such as Department of Biotechnology, Department of Science and Technology, etc. (Fig. 1). Indian agricultural research receives very little funding from international donor agencies. Within each institute, the decision on internal resource deployment for project funding is almost exclusively made by the administration with little freedom to scientists either in influencing the size of funding or in its utilization. Almost all ICAR review committees including the most recent Mashelkar Committee had urged the liberating ICAR administration from the intense grip of bureaucracy, ensuring a greater say for professionals in its running, delegating more powers to Directors of its institutes and full financial powers to the project leaders/principal investigators. Mashelkar Committee also recommended earmarking at least one-third of the funds available for research for competitive grants.

PERIODIC PERFORMANCE ASSESSMENT

Earlier procedures concerning recruitment, transfer, promotion and other service conditions adopted in agricultural research institutes and colleges were the same as those prescribed by the State governments for administrative departments. "Under such a procedure there were rather frequent changes in the job occupied by scientists and there was little scope for acquiring a deep knowledge or a position of authority on any particular topic or crop. The scientists under such administrative set-up had to become generalists rather than specialists and tended to attach more importance to administrative aspects of their work, rather than become wedded to academic and research pursuits" (Swaminathan, 1969).

A major change in the research administration of the ICAR was introduced since 1973. This reform embraced many aspects of management of organization, institutes and the projects. This reform institutionalized periodic review of scientists and institutes. The hallmark of this change is embedded in the new personnel policy called Agricultural Research Service (ARS) introduced in 1975 covering scientific and technical staff on recruitment, promotion and deployment. The ARS is a central service with a cadre strength combined for all grades, which for the first time in the ICAR brought in a “scientist-centric” rather than the “post-centric” career advancement policy with periodic review of scientists. This allows young scientists entering in research career to move up to the highest grade equivalent in pay to higher managerial or administrative positions under the system, without need to shift one’s field of specialization. This service also “de-glamorized” the managerial positions by making appointment to such positions tenurial with likelihood of person appointed therein returning to the research position on completion of such tenure. This encourages scientists for continuous engagement in research and to attain excellence with no distraction to those keen on continuing in research without switching over to managerial positions merely to gain higher salary.

The ARS also created a close nexus between the personnel policy and the project management system in ICAR. Every scientist has a major role in the research project activities, which have clearly defined goals and activity milestones with time lines. There is a project review system under ARS with focus on individual scientist performance and this is conducted regularly at annual and quinquennial intervals. Scientists are required to submit every year an Annual Assessment Report (AAR), which has in one part a self-assessment based on the project work and in another part an official assessment of the performance and the personal attributes of the scientist. The concerned Head of Department and/or the Director perform the official assessment on the AAR of a scientist. The progress in relation to the set project goals and related professional outputs constitute the basis for the annual in-house assessment. The AAR is being maintained as confidential on the reason that it has administrative assessment of the scientist. This confidentiality and associated opacity of the annual assessment, unfortunately offers opportunity for unfair practices. In addition, the progress and operational problems of all projects are reviewed annually at the SRC/RAC. There is however, no linkage between the outcome of the SRC/RAC review and the administrative assessment. In this context the recent recommendation of Mashelkar Committee to make SRC the backbone of performance appraisal system of the individual scientist merits considerable significance.

Apart from the annual assessment, the career advancement of every scientist is linked with quinquennial assessment of project-based contributions. This assessment is done by an external peer committee constituted at the institute level with the approval of the Agricultural Scientists’ Recruitment Board (ASRB) or by a similar committee constituted by the ASRB. ASRB, founded in 1976 along with the introduction of ARS, is an independent body with the mandate to

recruit scientists at entry level through an all India competitive examination and at all higher levels for the lateral entry through advertisement and to conduct periodic assessment of scientists for their career advancement (Fig. 2). It also conducts recruitment of technical service personnel at higher levels. The ASRB is accountable to the President of the ICAR, who is the Central Minister for Agriculture. The ICAR also has a National Academy of Agricultural Research Management (NAARM), which provides required training to new entrants to the Agricultural Research Services.

The periodic institutionalized review system for each institute or major project like AICRP and similar network project introduced during reform of ICAR during 1973 is called the quinquennial review. An external team of experts called quinquennial review team (QRT) conducts this review. This is a comprehensive evaluation of institutional performance with reference to its mandate in research, education and extension, as the case may be, and the priority tasks assigned during the review period. This review may go to the extent of assessing the institute accomplishments, examining the process used in research planning, prioritization, project development and implementation as available from the records of RAC/SRC, examination of distribution and utilization of funds across divisions, projects, etc. The institutes are bound to take corrective or otherwise actions on the recommendations of the QRT in technical area within a prescribed time frame and also make a report on such action to the ICAR administration and the institute Management Committee. Actions on QRT recommendations pertaining to administrative issues are taken with the approval of the head quarter.

At the ICAR level, periodic review of its role, effectiveness in addressing its national mandate and structure is reviewed periodically by a high powered committee of experts including farmer representatives appointed by the President of ICAR or the Government of India. Since independence, four such committees have examined the functioning of the ICAR. The Agricultural Research Review Team appointed in 1963 was the first one to conduct such review. This was headed by Dr. M. W. Parker of the USDA with three non-Indian and three Indian expert members. The recommendations of this Committee submitted in 1964 led to the reorganization of ICAR in 1965 and reforming of Indian agricultural R&E, paving the way for the emergence of the NARS.

A committee headed by Mr. Justice Gajendragadkar in 1972 conducted the second review. This review recommended greater autonomy to ICAR with flexibility in operation and management procedures. This led to the creation of the Department for Agricultural Research and Education (DARE) under Ministry of Agriculture and the ICAR being shifted from the control of Department of Agriculture to the DARE, with the Director General (DG), ICAR also upgraded to have a dual responsibility of DG-ICAR and the Secretary to the Government of India in the DARE. It was based on this report, the ICAR had devised the new personnel policy contained in the ARS and established an independent ASRB to subserve the new personnel policy. The structure of the ICAR was modified

with Minister of Agriculture as Chairman of the Council, the DG, ICAR as the Chairman its Governing Body, Norms and Accreditation Committee under DG for Agricultural Universities and scientific panels, etc. For operational purpose the country was divided into 8 agro-ecological regions and each with a Regional Committee under DG. It is also notable that since 1973, ICAR infrastructure on R&D expanded very rapidly.

The third review committee on ICAR was appointed in 1987 and headed by Dr. G.V.K. Rao. By the time this review was conducted the regional research capacity in every Indian State has immensely enhanced with the establishment of SAUs and some of the States having two to four Agricultural Universities. Dr. G.V.K. Rao's Committee in its report (1988) suggested that the regional research problems should be tackled by SAUs and other State agencies created at a considerable public cost. With this change in roles, the ICAR is to concentrate on national level planning of agricultural research and to undertake basic and strategic research pertaining to problems of national importance. The ICAR may attend to regional problems only when SAUs and the State agencies are inadequate in handling these problems. In this process the Committee wanted the ICAR institutes to earn leadership role in their respective areas. The report also commented on the inadequacy of the ICAR to be self-critical and self-correcting as well as a decreasing ability to take a system-wide view and coordination. The only important outcome from these recommendations is closure of some of the regional centres of ICAR institutes and review of AICRPs leading to winding up of a few projects, which outlived its objectives.

The fourth and more recent review committee was appointed in 2004 with Dr. R.A. Mashelkar as the head to review the management structure at the ICAR head quarter and devolution of administrative power from headquarter to the institutes. The Mashelkar committee in its report submitted in 2005 recommended strengthening the autonomous status of ICAR and empowering its the Governing Body with greater powers in decision-making, a greater say to professionals in the running of ICAR, and decentralized administration with full powers to manage the institute by the directors, and full financial powers to the project leader/principal investigators in managing the research projects (Anonymous, 2005a). It also recommended according primacy to the RAC in managing the scientific portfolio of the institute and making Staff Research Council the backbone of performance appraisal system both in respect of the individual scientist as well as the institution. Recommendations of this report are yet to be acted up on.

The Planning Commission of India appointed another Task Group headed by Professor M.S. Swaminathan in 2004 on revamping and refocusing national agricultural research. The Task Group submitted its report in 2005. Some of the important recommendations of this Task Group are new patterns in research design and implementation with high cooperative endeavour and accountability, strengthening strategic, applied, anticipatory and participatory research in plant and animal sciences, urgency for finalizing science-based national biotechnology

policy, initiation of national challenge programmes in critical and priority areas and fostering public–private partnerships. This Task Group urged to take immediate steps to permit scientists to work without their hands and feet, tied by unnecessary inelastic regulations. It also exhorted for a re-look and re-engineering of KVKs to catalyse the agricultural transformation and to bring a paradigm shift from unskilled to skilled work in agriculture (Anonymous, 2005b). In addition to these major review teams, several in-house reviews of specific programmes of the ICAR, such as the AICRP, ICAR linkage with SAUs, etc. were held during last two decades.

SCIENTIFIC MANPOWER AND PERSONNEL POLICY

This vast network of ICAR with 95 institutions, 84 AICRPs and 15 Network projects has manpower of about 18,172 personnel with 4,539 scientists engaged in research, teaching and research management (Table 4). The 39 SAUs across the country and one Central Agricultural University that together constitute a major component of NARS (Fig. 1) are entrusted with regional mandate on agricultural research, education and extension. Public sector institutions, which account for more than 95% of scientific manpower, are estimated to have about 18,172 scientists (Table 4). This does not include manpower deployed in public extension systems under the Departments of Agriculture of each State. More than three-fourth of the scientific manpower resources are in States, which account for half of the national R&E expenditure. With nearly uniform salary patterns, this reveals structural weakness in terms of support per scientist available under the State system (Table 2). The public research scientific manpower strength, in other words, is 14 agricultural scientists for every million population. Among these scientists, many discharge non-research responsibilities like teaching, technology transfer and research management. Adjusting the number of scientists by share of research expenditure relative to extension and education

Table 4. Scientific manpower in ICAR/SAU system (Jha and Pandey, 2005)

	All ICAR institutes			All SAUs			Grand total
	TNS	FTR	S-Ph.D.	TNS	FTR	S-Ph.D.	
1992	4,092	2,999	68.8	17,678	8,132	62.6	21,770
2001/02	4,539	3,069	75.7	13,633	5,810	69.6	18,172
AAS		43.8			45.7		
Assi P %		43.3			45.4		
Asso P %		39.3			34.9		
Prof %		17.4			19.7		

TNS = Total number of scientists; FTR = Full Time Researchers; S-Ph.D. = Scientists with Ph.D.; AAS = Average age of scientists; Assi P = Assistant Professor; Asso P = Associate Professor; Prof = Professor.

(for ICAR) and percent time spent on research (for SAUs), the number of full-time scientists in research under NARS in 2001 was estimated as 8,879 (Table 4) (Jha and Pandey, 2005). On this basis, the actual number of full-time scientists for every million population is 7.4. With the decreasing recruitment of young scientists into NARS, the average age of scientists in ICAR is about 45 (Table 4) with 43% among them being older (Jha, 2001). Two other important constraints hampering scientific productivity are the decline in scientific manpower in the State system and the stagnation in the Central system.

Recruitment of scientists in ICAR and SAUs differs in important respects. There are also differences in the hierarchy of scientific cadres in these two research systems. Under the ICAR, there are essentially five scientific grades between the entry level Scientist grade and the grade of Deputy Director General, not including the Director General. The Director General, who is also the Secretary to the DARE, is an employee of the Government of India and not the ICAR. The hierarchical grades from bottom up are Scientist, Scientist (Selection Grade), Senior Scientist, Principal Scientist and Deputy Director General. All these five grades are covered by the ARS system. The relative proportion of scientists in the three grades is presented in Table 4. Apart from Deputy Director General, there are few managerial grades, such as the Head of Division, Project Coordinator, Zonal Coordinator, Joint Director, Directors Central institutes and NRCs and Assistant Director General. All these grades are equivalent to Principal Scientist grade, but invested with variable research management authority. The Directors of National institutes including those with DU status are in the grade of Deputy Director General. Recruitment of all scientific personnel is conducted by the ASRB. Selection to the entry level Scientist grade in all disciplines is made through an all India ARS competitive examination conducted by the ASRB. Career advancement system under the ARS allows vertical mobility from the Scientists grade to Principal Scientist grade through the five-yearly assessment process monitored by the ASRB. Entry into ICAR is also possible in grades from and above Senior Scientist, including in all managerial grades up to the Deputy Director General through lateral recruitment system. These selections conducted by the ASRB with the help of peer committees after advertising the vacancy in India and Indian Embassies abroad. All appointment to all managerial positions is by such selection and for tenure of five years, with possibility for extension to a second tenure.

Unlike in the case of ICAR, the SAUs do not have a centralized recruitment and career assessment system. As the SAUs are under different States, each of them follows an independent recruitment and career assessment system with a broader uniformity. When there are more than one SAU in a State, all of them often follow a common recruitment and career assessment system. Therefore, there is considerable variation in these processes, despite efforts from ICAR to harmonize this system. There are essentially five grades of faculty/scientists under the SAU system. These hierarchical grades from bottom up are: Assistant Professor, Assistant Professor (selection grade), Associate Professor, Professor and Vice

Chancellor. The relative proportion of scientists in the three basic grades is presented in Table 4. Vice Chancellor is appointed by the Chancellor, who invariably is the State Governor, on the recommendations of the State government, under the guidance of an expert committee. This appointment is for a tenure, which varies across States from three to five years. Other managerial positions in the SAUs are the Head of Department, Dean, Director of Research/Education/ Extension, etc, which are all equivalent to the grade of Professor with invested managerial authority. Appointment to these positions is made either by selection or by rotation among Professors on seniority basis for a fixed tenure. In general, there is very little scope for lateral entry to most of the senior faculty grades or managerial grades in SAUs. Recruitment to SAUs is also largely confined to candidates from the respective State or even from the region within the State, when there is more than one university in a State with each of them mandated to specific region. This is causing a great deal of inbreeding within SAUs. While there is flow from SAUs to the ICAR, the reverse flow is very restricted and rare.

Under the ARS system, the five-yearly assessment is built in a reward system for jobs well done. This allows an additional pay (as salary increments) in the existing grade. The ICAR has also instituted many special awards and rewards for professional excellence. One of the important recognition for professional excellence is the institution of chairs of National Professors and National Fellows to outstanding scientists, who had been successful in creating a culture of basic research. This is open to all in the NARS. This scheme seeks to build centers of excellence in basic research in the disciplines of agriculture and allied sciences in upcoming areas of national importance. There are also many prestigious awards and recognition instituted within the ICAR system. There are about 15 categories of awards open to individual excellence in research across NARS, best institution within ICAR and among SAUs, best all India coordinated project and best and most successful multidisciplinary research team. To recognize the good work of young scientists and women scientists, there are awards for best postgraduate research leading to doctoral degree and for best research by women scientists. In addition, there are special awards for best research contribution made from tribal or backward area, for outstanding performance by the KVKs, for best performance in technology transfer and for best journalism related to agricultural science, R&E, etc. In addition, there are also few awards to excellence in performance in Indian agricultural research instituted by some of the ICAR institutes, SAUs and private organizations.

CONCLUSION

The Indian Agricultural Research System, which is one of the largest in the world, has concurrent responsibility for agricultural R&E. It thus, combines the functions of other Indian R&D organizations like the Council of Scientific and Industrial Research (CSIR), the Indian Council of Medical Research (ICMR) and similar Indian scientific bodies, with the functions of the UGC with respect

to channeling government support to the Agricultural, Animal Sciences and Fisheries universities.

It combines in its legal structure the autonomy characteristic of societies (ICAR is a registered society) with the governmental authority vested in a department of the Government of India (Department of Agricultural Research and Education – DARE). By designating the Director General of ICAR also as Secretary to the Government of India in the DARE, ICAR will have direct access to the cabinet of India.

It is the only scientific organization, which operates a national Agricultural Research Service (ARS), thereby providing for mobility of scientists, opportunities for promotion without the occurrence of vacancies, and the ability to serve the remotest regions of the country. ARS has some of the features of the Indian Administrative Service (IAS), but differs from IAS in providing opportunities for lifelong specialization in one's area of expertise (Plant Breeding, Agronomy, Biotechnology, etc.).

Through All India Coordinated Research Projects, the Indian Agricultural Research System is able to foster inter-institutional and interdisciplinary cooperation irrespective of the administrative organization to which the scientist belongs. Thus it is able to assume and foster leadership in partnership.

The distinctive features of the Indian Agricultural Research System have influenced greatly the structures of several other agricultural research systems in Asia, such as the Pakistan Agricultural Research Council, the Bangladesh Agricultural Research Council and the Philippine Council of Agricultural Research and Development.

REFERENCES

- Anonymous. 2005a. Accelerating ICAR's journey towards excellence. Report of the ICAR Reorganization Committee, July 2005, p.79. Source: <http://72.14.235.104/search?q=cache:weJR6E11ts0J:www.icar.org.in/%255Creports%255+Creport-mashelkar.doc+&hl=en&gl=in&ct=clnk&cd=1>
- Anonymous. 2005b. Report of the task group on revamping and refocusing of national agricultural research. January, 2005, Planning Commission, Yojana Bhavan, Government of India, New Delhi, India, p.282.
- Bala Ravi, S. 1989. Project management and management milieu in agricultural research. In: K.V. Raman, R. Choudhary, A. Bandyopadhyaya, and S. Maiti (eds.) *The Role of Scientific Research and its Management in Accelerating Socio-economic Transformation*. Agricole Publishing Academy, New Delhi, India, pp.143–156.
- DARE, 2006. DARE/ICAR Annual Report-2005–06. <http://www.icar.org.in/anrep/200506/index.htm>
- Desai, D.K. 1989. Modernising agriculture and the role of agricultural research scientists. In: K.V. Raman, R. Choudhary, A. Bandyopadhyaya, and S. Maiti (eds.) *The Role of Scientific Research and Its Management in Accelerating Socio-economic Transformation*. Agricole Publishing Academy, New Delhi, India, pp.3–23.
- Evenson, R.E., C.E. Pray, and M.W. Rosegrant. 1999. *Agricultural Research and Productivity Growth in India, Research Report 109*. International Food Policy Research Institute (IFPRI), Washington, DC, p.88.
- ICAR. 2006. ICAR at a Glance, folder published by the ICAR, New Delhi.

- ICAR. 2006. ICAR website-<http://www.icar.org.in/>
- Jha, D. 2001. Agricultural research and small farms. *Indian Journal of Agricultural Economics*, 56(1): 1–23.
- Jha, D., and Pal, S. 2003. *Agricultural Research & Technology Status, Impact and Contemporary Issues*. IFPRI, Washington, DC.
- Jha, A.K., Pal, S., and Joshi, P.K. 2004. Efficiency of public-funded crop science research in India. *Agricultural Economics Research Review* 17: 17–27.
- Jha, D., Kumar, P., Mruthyunjaya, S., Pal, S., Selvarajan, and Alka, S. 1995. Research priorities in Indian agriculture. NCAP Policy Paper No.3, National Centre for Agricultural Economics and Policy Research, New Delhi, India.
- NFC. 2006. National Commission on Farmers. Third Report – Serving Farmers and Saving Farming; 2006: Year of Agricultural Renewal. Ministry of Agriculture, Government of India, New Delhi, India, p. 307.
- Paddock, W., and Paddock, P. 1965. *Famine 1975! America's Decision: Who Will Survive*. Little Brown, Boston, MA (1976).
- Pal, S., and Byerlee, D. 2003. The Funding and Organization of Agricultural Research in India: Evolution and Emerging Policy Issues. Policy Paper 16, National Centre for Agricultural Economics and Policy Research (ICAR), New Delhi, India, p.53.
- Pal, S., Joshi, P.K., and Kumar, A. 2000. Agricultural research prioritization: concepts and approach. *ICAR News* 6(3).
- Pardey, P.G., and Beintema, N.M. 2001. *Slow Magic: Agricultural Research a Century after Mendel*. IFPRI, Washington, DC.
- Pardey, P.G., Roseboom, J., and Craigo, B.J. 1999. Agricultural R&D investments and imports. In: Alston, J.M., Pardey, P.G., and Smith, V.H. (eds.) *Paying for Agricultural Productivity*. Johns Hopkins University Press, Baltimore, MD.
- Pardey, P.G., Beintema, N.M., Dehmer, S., and Wood, S. 2006. *Agricultural Research: A Growing Global Divide?* IFPRI Food Policy Report. IFPRI, Washington, DC, August 2006.
- Pray, C. 2002. The growing role of the private sector in agricultural research. In: Byerlee, D., and Echeverria, R.G. (eds.) *Agricultural Research Policy in an Era of Privatization*. CAB International, Wallingford, UK.
- Raman, K.V., Balaguru, T., and Manikantan, P. 1988. National agricultural research, education and extension education systems in India. National Academy of Agricultural Research Management, ICAR, Hyderabad, India, p. 302.
- Randhawa, M.S. 1979. *A History of the Indian Council of Agricultural Research, 1929–1979*. ICAR, New Delhi, India, p. 510.
- Ranjitha, P., and Mruthyunjaya, P. 2005. Total factor productivity in Indian agriculture: impact of research. In: Joshi, P.K., Pal, S., Birthal, P.S., and Bantilan, M.C.S. (eds.) *Impact of Agricultural Research – Post-Green Revolution Evidence from India*. National Centre for Agricultural Economics and Policy Research, New Delhi, India, pp. 17–24.
- RCA. 1928. *Royal Commission on Agriculture in India*. Government of India, Central Publication Branch, Calcutta, India.
- Swaminathan, M.S. 1968. Government policy and administration of agricultural research. Lecture at the Indian Institute of Public Administration, New Delhi, India, p. 6.
- Swaminathan, M.S. 1993. The Delhi seminar. In: Swaminathan, M.S. (ed.) *Wheat Revolution – A Dialogue*. Macmillan, Madras, India, pp. 5–160.
- USDA. 2003. United States Department of Agriculture, Foreign Agricultural Service. Public Law 480 sales programme: A brief explanation of Title I. <http://www.fas.usda.gov/excredits/FoodAid/p480brief.html>

CHAPTER 17

AGRICULTURAL SCIENCE IN THE NETHERLANDS

K. VERHOEFF¹, C. MOLLEMA², AND R. RABBINGE³

¹*Former Director Science & Technology, Ministry of Agriculture, Nature Management & Fisheries;*

²*Senior Officer Wageningen University and Research Centre; currently Radboud University,*

Nijmegen; ³University Professor, Wageningen University & Research Centre

INTRODUCTION

Mainly due to its geographic position, easy access to the sea as well as to surrounding countries in Western Europe, flat and fertile soils and large numbers of human populations nearby, agriculture in the Netherlands was, and still is, an important economic activity. It ranks second worldwide as exporting country for agricultural products. This enormous achievement for such a small country is traditionally explained by its very effective cooperation between education, extension, and research: the EER triptych.

During the last century, however, great changes occurred. While agricultural practice, that is primary production, and the political influence of farmers decreased, agricultural science developed at the same time from isolated activities into a coherent research organisation. In particular during the last decades some major transitions occurred which we place in a historical context.

These important transitions include shifts from:

- the economic importance of primary production towards processing industry
- supply-driven research towards demand-driven research
- mono-disciplinary research towards multi- and interdisciplinary research
- agricultural sciences towards life sciences
- solutions for isolated problems towards solutions for bottlenecks in production chain perspectives.

Finally this paper underlines the importance of a strong agricultural knowledge infrastructure, in which strategic research aiming at mid-term solutions keeps a key position.

By reading this paper, two important aspects of agricultural research in the Netherlands should be borne in mind.

The first one is that in the Netherlands, agricultural research was, and still is, closely connected and intertwined with technical and environmental research

such as agricultural machinery, soil science, soil and water management, and nature conservation. In this paper we mainly focus on research related to agricultural production, hence linking to what is covered by agricultural science in most other countries.

The second one is that in the Netherlands agriculture in its broader sense is separated into horticulture and agriculture. Horticulture includes the production of vegetables, flowers, pot plants, shrubs, trees, bulbs, and mushrooms, while agriculture in its smaller sense includes the production of arable crops and animal husbandry.

HISTORICAL DEVELOPMENTS AND STATE POLICY ADDRESSING AGRICULTURAL ACTIVITIES AND AGRICULTURAL SCIENCE UNTIL 1987

The formation of the Netherlands as a state with a central administration dates from 1795, when the various Dutch provinces came together to form the Batavian Republic. Agriculture and the rural population became somewhat more 'visible' than in the preceding periods.

The first activity of the government towards the farmers was the establishment of a fund to compensate farmers for losses due to rinderpest in 1799 (van der Poel, 1949).

In 1800 the government founded an Agency for Agriculture. The activities of this agency concentrated on statistics of agriculture and these were in fact the first agricultural statistics in Dutch history.

In 1813, the Republic became a monarchy under King William I, and the aforementioned Agency for Agriculture was closed. In 1815, however, a new law on education formulated the establishment of university chairs in land-household studies. Professors were appointed at the universities of Leiden, Groningen, and Utrecht. Subjects taught not only covered agricultural economics, but also chemistry and natural science.

Although these positions were abandoned in 1876, they could be regarded as the first state-financed facility for agricultural science in the Netherlands; however, no experimental research was carried out.

THE BEGINNING OF AGRICULTURAL RESEARCH

In the 1840s, various provincial Agricultural Societies were formed, who all favoured the exchange of information, but also stressed the importance of chemistry in agriculture. These societies were not in a financial position to establish experimental stations and they urged the government to do so. In 1863 a new law on education initiated education in agriculture and a locally financed school was opened in 1873 in Wageningen. Financing was taken over by the government in 1876 (Benda, 1976). One year later, an Experimental Station was added to that school. Wageningen was chosen because of the presence of various

different soil types in the surrounding area. Furthermore, farmers preferred to have their sons living in a small city.

In 1876, A. Mayer started work in Wageningen and *this year is usually regarded as the beginning of agricultural science* in the Netherlands. In 1860, Mayer had already established a privately funded experimental garden in the city of Deventer (Maat, 2001).

In the years 1880–1900 a critical situation occurred in agriculture, caused, among other factors, by the bulk import of cereals from the USA and Argentina. Instead of protective economic measures, the government decided to favour a more liberal policy: no economic barriers, and if necessary only general regulations, which for a country with an important international trade, is almost a must. Instead, state support was given for improving (scientific) education and for the establishment of experimental stations. This was argued in two ways: one reason was the maintenance of objective research, the other was the lack of funds by farmers to pay in full the costs of experimental stations. Another important aspect was the dissemination of results to farmers, which was done by the state-funded extension service.

From the middle of the 19th century onwards, the policy of the Dutch government has been to support education, extension and research, the EER triptych, an indirect and very effective method of improving the competition power of farmers and growers (see later). This policy was supported by exchange of information among farmers and growers. In addition, growers formed together ‘study groups’ on specific crops, leading to an exchange of information between them.

In addition to this stimulus by the government, the production circumstances were improved by land reclamation and land improvement strategies.

The farmers themselves organised cooperatives to strengthen their position on the market against, for example, the potassium industry. This cooperative movement was welcomed and supported by the government. Well-understood self-interest, the nature of the first cooperative illustrates the reasoning for the establishment of additional cooperatives.

POLITICAL POSITIONING OF AGRICULTURE

Politically, agriculture had its own ministry since 1945, albeit together with other sectors within the Ministry of Food Supply, Agriculture and Fisheries. Later this was changed to ‘Agriculture and Fisheries’; to ‘Agriculture, Nature Management and Fisheries’ and more recently to ‘Agriculture, Nature Management and Food Quality’.

Before 1945 the portfolio ‘agriculture’ swept from one ministry to the other. The establishment of a Ministry of Agriculture coincided with the growing importance of agriculture, the development of agricultural research and its importance for the Dutch economy. One could say that the knowledge from research was immediately implemented in the production chain. This knowledge

development had a high economic value. In other words, knowledge intensity and quality are typical characteristics of agricultural produce.

Nowadays, the economical impact of agriculture is reflected by approximately 10% of the Gross National Product. Moreover, the Netherlands ranks as exporting country second worldwide in agricultural products, both primary products as well as those from agro-technology and food industry, some €40–50 billion annually. Today, around 700,000 individuals are working in this sector in the Netherlands.

ESTABLISHMENT OF COMMODITY-ORIENTED EXPERIMENTAL STATIONS AND DEMONSTRATION FARMS AND GARDENS

Horticulture

At the end of the 19th and the beginning of the 20th century, growers established demonstration gardens in centres of production of vegetables and flowers grown in glasshouses and in the centre for fruit production. This more or less coincided with a government activity to form specialized horticultural schools in these centres. The directors of the schools usually became also director of the demonstration gardens, while teachers participated in experiments carried out in these gardens. Thus, almost from the beginning it was a public–private activity. The demonstration gardens started by carrying out variety trials and plant nutrition experiments. Soon, other aspects of plant production were incorporated, like improving growing conditions and quality of products as well as diseases and pests control: the demonstration garden became an experimental station.

Predominantly applied research was carried out for the commodities involved, but also some strategic research was done. Gradually these stations became responsible for the commodities nationwide, while demonstration gardens were established in other production centres in the country.

Bulb research started by activities of growers, who contacted the University of Amsterdam to do research on a bacterial disease in hyacinths in 1884. Later, they had contacts with the school in Wageningen for research on nematodes in bulbs. In 1918, this led to the establishment of a Bulb Research Centre in Lisse as a department of the School in Wageningen. This situation lasted until 1965, when the Bulb Research Centre received the status of an experimental station, albeit, that strategic research on bulbs remained an important part of the research activities.

Applied research on mushrooms started by the establishment of an experimental station by the Mushroom Growers Association in 1957. Soon, the government became a partner in this station. As there were no scientific counterparts in the Netherlands, both strategic and applied research was carried out in the station.

Applied research on field crops started as government funded activities in the 1890s. This work was carried out by the newly formed Experimental Station for

Field Crops and Pasture Research in Wageningen. A rather wide range of field crops was included in the research programme, while 'translation' of research carried out elsewhere formed an important aspect of the work. This station existed until 1971, when it was split into two new Experimental Stations, one for Field Crops, including vegetables grown in the open, and one for Cattle and Pasture research, both located in Lelystad. The existing Experimental Station for Field Vegetables Production, located in Alkmaar, merged with the station in Lelystad. In the beginning, demonstration gardens were rather independent, but from the 1960s onwards, a close cooperation with the experimental stations has been established.

Before 1971, farmers at different locations in the country established a number of demonstration farms.

In 1945, two special Experimental Stations for bee research were opened. One was located in Hilvarenbeek (the 'Ambrosiushoeve') and one in Wageningen: the Institute for Bee Research. The latter one was closed in 1959, while the former one was moved to Wageningen in 2004 where it merged with other Research Institutes (see Developments since 1987).

Agriculture

Applied research in animal husbandry has a different history. Research on animal diseases was done by the University of Utrecht, while the College of Agriculture in Wageningen (predecessor of Wageningen University) studied various aspects of cattle and pig production. In addition, three discipline-oriented research institutes did research on animal nutrition; on physiological aspects of animals, on fertility and breeding. The research on animal diseases concentrated on disease prevention and control. All had some applied research in their research agenda. Later in the 20th century, farmers on cattle, pig and poultry husbandry had established a number of demonstration farms. Nevertheless, an Experimental Station for Cattle, Sheep and Horse Research was established by the Ministry of Agriculture in Lelystad in 1971 and a Pig Experimental Station in Rosmalen in 1984.

The private industry also played an important role in executing research, as is described below. Together with effective agrochemicals, this led to a flourishing agricultural industry.

ESTABLISHMENT OF VARIOUS DISCIPLINE-ORIENTED RESEARCH INSTITUTES

Since the late 19th century, and next to the State Agricultural College a large number of various Agricultural Research Institutes were established in the Netherlands. These institutes were mainly discipline-oriented and characterised by strategic research, aiming at mid-term solutions. The fate of these institutes varied, some were short-lived, and others remained up to more than a century,

although not always keeping their original name. In particular in the period between 1940 and 1960, a vast increase in the establishment of these disciplinary-oriented institutes was observed.

Many of these research institutes were located in Wageningen, while others were established within the region of interest, e.g. the Institute for Fishery Research at the coast in IJmuiden and the Agricultural Economics Institute in The Hague (near the Ministry of Agriculture).

In 1975, there were more than 25 different agricultural research establishments in the Netherlands, all financed by the government (Maltha, 1976).

For most of the relevant disciplines in agriculture there was a separate Research Institute, viz. Plant Protection (IPO), Breeding in Arable Crops (SVP), Breeding in Horticultural Crops (IVT), Soil Fertility and Plant Nutrition (IB), Agro-biology (IBS), Applied Nuclear Energy in Agriculture (ITAL), Plant Genetic Resources (CGN), Poultry Husbandry (COVP), Animal Health (CDI, a merger of different establishments in the country), Animal Nutrition (IVVO), Animal Husbandry (IVO), Fisheries (RIVO), Mechanical Engineering and Rationalisation in Agriculture (ILR), Horticultural Engineering (ITT), Agricultural Industrial Buildings (ILB), Storage and Processing of Horticultural Products (IBVT), Storage and Processing of Agricultural Products (IBVL), Nature Management, two separate small foundations soon brought together in one institution (RIN), Forestry (De Dorschkamp), Soil Mapping (STIBOKA), Rural Area and Water Management (ICW), Pesticides (IOB), Food Quality and Safety (RIKILT) and Agricultural Economics (LEI).

These institutes were part of the Ministry of Agriculture and their staff was formally appointed by the Minister. The number of staff per institute was different, ranging from about 40 to approximately 200.

This listing has to be completed by mentioning the establishment of an institute for fundamental research, the Centre for Plant Physiology Research (CPO), also financed by the Ministry of Agriculture.

It should be noted that some of the research institutes mentioned above were established by the Organisation for Applied Research (TNO). This was in a period where the positioning of strategic research institutes was unclear: in one organisation, i.e. TNO, or under the umbrella of the Ministry of Agriculture as far as agricultural research was concerned. As was decided for the latter option, the Agricultural Research Institutes were brought under the Ministry of Agriculture.

In addition to the public financed institutes, the Netherlands Institute for Dairy Research (NIZO) was established by the Dutch dairy industry in 1948, close to Wageningen. This institute served as a joint research unit for all Dutch dairy enterprises. In 1995, the name was changed in 'NIZO Food Research', focusing on food in general, including dairy products. From then on it started generating its income solely by carrying out confidential research projects for the international food industry. NIZO became an independent institution in 2003.

Although the research carried out was primarily for the Dutch growers and farmers, there was an important spin-off in transferring knowledge to the developing world.

In relation to this knowledge transfer, three other establishments have to be mentioned, viz. the International Agricultural Centre (IAC), the Institute for Land Reclamation and Improvement (ILRI) and the International Soil Reference and Information Centre (ISRIC), all located in Wageningen.

The IAC has two functions: (1) organising and accommodating special courses for staff and students from developing countries and (2) being the home base for Dutch scientists sent abroad, to execute research and/or teaching and training projects in developing countries. The IAC had a basis funding from the Ministry of Agriculture, but obtained also grants from the Ministry of Foreign Affairs, Development Collaboration.

ILRI operates internationally on projects related to drainage and irrigation (training and teaching professionals, development of instruments). ILRI was originally funded by the Kellogg Foundation, later on by the Ministry of Agriculture and other funding agencies.

ISRIC was established by the International Soil Science Society and adopted by UNESCO in the 1960s. It is financed by the Ministry of Science and Education and in part by the Ministry of Development Collaboration, similar to the IAC.

These three institutes played a major role in positioning Wageningen University and the research institutes as knowledge centres, with a strong role in the agricultural sector.

ESTABLISHMENT OF THE AGRICULTURAL UNIVERSITY

Like in other cities in the late 19th century, also the local high school in Wageningen taught agriculture as one of its subjects. In 1876, however, the national government took over this local council's school and turned it into the State Agricultural School. This event is considered as the start of national agricultural education in the Netherlands.

The agricultural education at the State Agricultural School in Wageningen developed to a higher level and from 1904 onwards, this school was called the National Higher School of Agriculture, Horticulture and Forestry.

The further development towards an academic establishment went on and was legally ratified in 1918. As of the 9th of March 1918, the school is the National Agricultural College. This day is ever since remembered as the '*Dies Natalis*'. From then on, the teachers were professors, not only responsible for teaching but also for research. The number of publications showed an exponential growth, and the first Ph.D. candidates graduated.

The various disciplines on which teaching and research was focused could be distinguished into six groups:

1. Basic sciences, e.g. mathematics, physics, chemistry, biology
2. Social sciences, e.g. sociology, agricultural law and history, dissemination and transfer of knowledge, business, and socio-economics

3. Soil, climate and labour sciences, e.g. mechanisation, climate and water management, soil fertilisation and plant nutrition
4. Plant sciences, e.g. agronomy, horticulture, forestry, crop protection, plant breeding;
5. Animal sciences, e.g. animal husbandry, animal nutrition, animal breeding, animal health (veterinary sciences were and still are exclusively taught and studied at the Utrecht University)
6. Post-harvest and processing sciences, e.g. technology, food processing, dairy, sales

After 1945, developments in education and research necessitated new legislation. In 1956 the national government approved the new statute of the Agricultural College. Twelve years later, the Agricultural College came under the jurisdiction of the Academic Education Act that governs all universities. It should be borne in mind that the Minister of Agriculture and not the Minister of Education and Science was responsible for the Agricultural College.

In 1986, in accordance to revisions in this Academic Act, the National Agricultural College, like other technical colleges in the Netherlands, became a university: the Wageningen Agricultural University, under the responsibility of the Minister of Agriculture.

The academic level continued to be enhanced by both the quality and quantity of publications. In particular the number of Ph.D. graduations, increased substantially, as is shown in Figure 1. Ph.D. theses in the Netherlands usually contain approximately five (published or submitted) relating articles, a general introduction, and a general discussion. Hence Ph.D. graduations contribute for a substantial part to the scientific productivity of the university.

Since the mid-1990s, the entire university participates in national and some specific Wageningen Graduate Schools. These schools are constituted by groups from various universities, forming a coherent education programme for Ph.D.

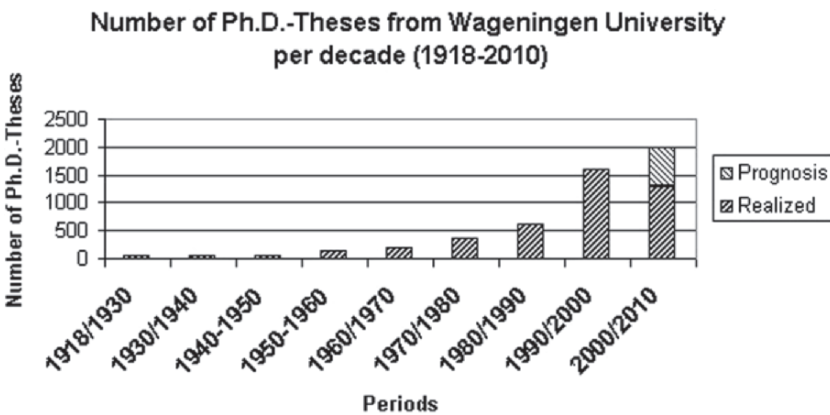

Figure 1. Number of Ph.D. Theses from Wageningen University per decade (1918–2010).

students in almost all disciplines. In Wageningen these Graduate Schools play a major role in research by permanent staff and Ph.D. students; approximately 80% of all research takes place intern the Graduate Schools. The overall programme of each Graduate School was assessed and recognised by the Royal Netherlands Academy of Arts and Sciences. Nowadays, international review panels assess both the educational and the research programme, every six years.

In the meantime, the library of Wageningen University developed into a European centre on agricultural literature and information systems.

The National Agricultural College also played a significant role in the former Dutch colonies, both in Indonesia and in the West Indies, where large-scale production of specialised plantations was developed. This rich tradition continues: research projects on tropical agriculture, rural development and nature management in developing countries are being performed or supervised by researchers in Wageningen. Nowadays, more than 40% of the Ph.D. students and about 30% of the MSc students participate in research programmes in developing countries, and many of them are not Dutch citizens.

In the 1980s there were about 90 full professorial chairs, each with a group of associate and assistant professors, technical and other supporting staff. At the end of the 1980s there came an end in the vast extension of disciplines and separate chairs and departments. Chairs were grouped into clusters and a selection of disciplines took place. Some years later, this process was followed by the formation of five departments namely Plant Sciences, Animal Sciences, Agro-technology and Food Sciences, Environmental Sciences and Social Sciences.

PROGRAMMING AND ASSESSMENT OF RESEARCH AND STIMULATION OF COOPERATION BETWEEN AGRICULTURAL RESEARCH ACTIVITIES

Programming of research

Apart from the overall governmental role of the Ministry of Agriculture for all agricultural research institutes and experimental stations, the management of each of these had a more complex structure.

Experimental stations had a governing body, usually consisting of farmers or growers, representatives from the commodity board and the Extension Service, i.e. the Ministry of Agriculture. Programming of research was done by this governing body, where problems occurring in the production of various crops were discussed and the necessary research added to the programme. When a serious problem appeared, additional personnel was often hired, or support was obtained from research institutes by stationing staff at the experimental station. Cooperation in research among experimental stations started in the 1970s leading to joint research programmes.

A system of assessment of the research on experimental stations did not exist until they were merged with the agricultural research institutes (see below).

Each *research institute* had a governing body, in which representatives from the relevant sector, the commodity boards, other institutes, universities and the Ministry of Agriculture participated. From the beginning, this body determined the research programme, based on the information from the researchers and on the progress made. In addition, for each institute, one or more 'Advisory Councils' were installed for specific research activities. In these councils participated representative experts on the crops or on subjects to be studied, e.g. on glasshouse culture or cereal production.

By stationing staff of research institutes at experimental stations, a closer link was obtained with applied research, and information was obtained on problems that could not be solved by short-term research.

From the early 1950s some institutes started to register their research programme in project-administrations. In 1966 the institutes began to classify their research projects according to a system, which covered all agricultural research. This resulted in 1971 in the first 'Index of Agricultural Research in The Netherlands', followed in 1972 by the first 'Multi-year Plan for Agricultural Research (1972–1976)'. These plans, in which the aim, the scientific and economic motivations, methods and facilities, costs and time planning were described, significantly determined the direction of research.

Up to 1990, when the research institutes were still part of the Ministry of Agriculture, proposals for new research programmes were discussed with the Advisory Council and approved by the Governing Board of the institutes. The Ministry financed the annual budget for the total programmes per institute.

Since the 1990s, an international expert panel did an assessment of the work of each institute, every four years.

From the start of the College of Agriculture, the professors of each discipline determined the research programme themselves, but undoubtedly they were influenced by problems originating from agricultural practice.

Since Wageningen University came under the same jurisdiction as other universities, it had also to follow rules for programming and financing. As a consequence, starting from the early 1980s, it had to submit a description of its entire research and education programme for periods of five years. The money for that period was supplied by the Ministry only after approval of the proposed programme by an independent external committee. This situation lasted only till the late 1990s. From then on the core-funding of the university was based on performance (e.g. student numbers and numbers of Ph.D. graduations in the last 2–3 years) and on a so-called strategic research component.

Per discipline, each education and research programme was peer-reviewed every 5 years, while the Inspection for Education monitored implementation of the recommendations. Later the peer review for the university's research programmes was done every 6 years by examining the programmes of the Graduate Schools in which it participated.

Cooperation between research establishments

Generally speaking, from the beginning of agricultural science, cooperation between research establishments and tuning in on demands of commercial holdings appeared to be rather difficult, with the exception of the research on experimental stations.

With the increase of discipline-oriented research institutes in the 1950s, this became a problem. At first, the government decided to establish a foundation with representatives of farmers and growers associations, the private industry, notably for agricultural machinery, and the Ministry of Agriculture, to stimulate cooperation and interaction between these parties. This did not work well.

In 1957, the 'National Council for Agricultural Research' (NRLO) was established by the government, at first under the umbrella of TNO, later under the Ministry of Agriculture.

In this council, all stakeholders such as policymakers, private NGOs and the institutes came together to prioritise research.

The NRLO staff kept track of all research activities, noted new developments and innovations and used that information as input in the discussions for new research programmes. In the 1980s, specific commodity and crop-oriented planning commissions were formed, in which the NRLO personnel acted as secretarial staff.

For the research institutes, the research agenda 'at large' was formulated in tripartite deliberations under the umbrella of the NRLO. The parties, i.e. knowledge institutions, the demand side, industries and NGOs and the government formulated in close collaboration the research agenda for the research institutions.

The NRLO was discontinued in the beginning of the 21st century (see below).

In the 1970s, another step was taken by bringing together all public-funded discipline-oriented agricultural research institutes into one organisation: the Directory of Agricultural Research (DLO). Before that time, a number of directorates of the Ministry of Agriculture were responsible for one or more research institutes involved in policy support for that directorate. This new directory controlled funding of research and this was another way of stimulating cooperation. As each institute had its own Governing Board, they could nevertheless act rather independently. This situation lasted until the end of the 1980s. Then a completely different system was introduced, based on a separation of research policy and executing research, which included a different way of financing research (see following section).

**THE EER TRIPTYCH AND OTHER INSTITUTIONS
IN THE KNOWLEDGE NETWORK**

As stated before, teachers on specialised horticultural schools carried out experiments in demonstration gardens while the directors of such schools often combined their function as head of the demonstration garden. This can be seen as the start of the

close cooperation between education and research, which took place at the end of the 19th and the beginning of the 20th centuries. The government, following its policy of indirect support of the agricultural sector, also financed the 'Extension Service'. This agricultural extension service cooperated closely with the experimental stations and usually (notably after 1945), the director of the experimental station was also head of the extension service, combined with the directorship of the specialised schools. This was the national and international well-known EER triptych, a network which had a very positive effect on the development of agriculture in this country: a direct and rapid flow of information from research into extension and teaching and implementation in practice and vice versa! The role of the EER triptych is clearly described by Leeuwis *et al* (2006).

In the EER triptych, also other institutions, predominantly privately funded, played a role in the agricultural research network.

The Organisation of Applied Research (TNO) established a technological institution for research on human nutrition, where, of course, agricultural products are included in the research programme. Farmer's organisations established an institute for chemical plant and soil analyses, later extended with analyses of soil contaminations by nematodes. Farmers funded an institute of applied research in animal feeding. Sugar beet farmers and the sugar industry established an experimental station for sugar beet research.

Growers and farmers founded their own *inspection services for quality control* (NAK) of planting material and seeds. Such inspections were and still are carried out in floriculture, vegetables, bulbs and shrubs; in seeds of grasses and cereals as well as in seed potatoes. Absence of diseases and pests as well as purity of the seed samples, are important parts of the inspections. In addition to inspections of plant and seed samples, also field inspections are carried out. These institutions developed their specialised 'inspection instruments', usually based on research carried out elsewhere in the Netherlands. The government supervises the privately owned 'Inspection Services'.

Quality control is also done by the Plant Protection Service (PD), an institution financed by the government. In addition to the development of diagnostics and methods for inspection, this institution played and still plays an important role in case of quarantine diseases and pests, as well as in import and export of agricultural products.

The large plant-breeding companies in the Netherlands were also important partners in the knowledge network. By demonstrating newly developed plant varieties, growers could see these improved varieties before they were on the market and could include the new varieties in their planting scheme immediately when the varieties became available.

The Ministry of Agriculture financed an 'Animal Health Service'. The main task of this service was identifying animal disease problems and as such was part of the knowledge network. Recently, this service was privatised.

In addition to the various institutions mentioned above, a number of other, usually smaller, private research establishments are active in the primary production chain in agriculture.

Participation of private companies in the knowledge network was stimulated primarily by specific subsidies, or within co-financed programmes, and the concentration of R&D divisions near the university and the research institutes.

SCIENTIFIC IMPACT

For many years 'Wageningen' is internationally recognised as a global centre of excellence in agricultural science. One of the reasons for this qualification is the early awareness for implementing systems approaches in agricultural science. Professor C.T. de Wit (1924–1993) and his successors integrated and applied basic sciences (mathematics, physics, chemistry and biology) in agricultural sciences such as soil science, agronomy, ecology, crop protection and land use. The department, Theoretical Production Ecology and Resource Conservation, was created and resulted in hundreds of Ph.D. graduates. This school has no equivalent so far in the world. It is mainly the success in this domain why 'Wageningen' is famous worldwide, in particular also in developing countries. Another reason for the international reputation of 'Wageningen' is the strong link between socio-economic and agricultural sciences. The integration between these sciences, and training in the interdisciplinary way of working is in Wageningen traditionally fully accepted and elsewhere less developed. It contributed considerably to the scientific impact of 'Wageningen'.

Despite being the smallest university in the Netherlands, Wageningen University shows remarkable success. According to 'Essential Science Indicators' from 2005, it ranks in the world top five with regard to scientific output and citations in the fields of Agronomic Sciences (third), Animal and Plant Sciences (fifth) and Environmental Sciences (fourth).

ECONOMIC IMPACT

As a result of public–private cooperation in agricultural research, the Netherlands has a leading role in some sectors. The most important are in breeding of potatoes and grasses, in developing new varieties in floriculture and vegetables, in mushrooms, in cattle breeding, in cheese making and in biological control of insect pests and diseases.

Breeding in potatoes has been a private, almost individual business by so-called 'hobby breeders'. However, the government stimulated this work through research at Wageningen University and the Plant Protection Service, by carrying out research on devastating potato viruses and nematodes. This work started soon after the establishment of the Plant Protection Service at the beginning of the 20th century. Results were used in the breeding programmes. Moreover, the government enabled better conditions for the breeders. Until 1941, a lack of protection of new varieties hampered the development of a large-scale potato-breeding industry. This changed, when some legal protection was obtained in

1941. This protection, 'breeders rights', was further improved in 1957; new varieties were protected for a period of 25 years.

Public-funded research started in the 1930s, leading to a special Potato Breeding Institute in 1948. From this institute, pre-breeding material was developed, e.g. containing resistance to nematodes and late blight, and released to potato breeders for the development of new varieties. Since 1945 a number of larger breeding companies, often as part of trading companies, have been established and potato breeding became big business. In close cooperation with the breeders, seed potato production became an important part of Dutch agriculture. Nowadays, annually about 900,000 tons of seed potatoes are being produced in the Netherlands, of which approximately 700,000 tons are exported.

Early 2006, the national government recognised the importance of potato breeding for the Dutch economy again and granted some large special programmes on potato breeding against major diseases, such as 'late blight', in the context of boosting the national knowledge infrastructure.

Breeding in grasses started at the beginning of the 20th century by private breeders. With the development of tetra-ploid grass genotypes by public funded research in the 1950s, a breakthrough occurred and many new varieties were produced, each adapted for growth under different climatic conditions and different soil types. The Netherlands now ranks second in the world production of grass seeds.

Although production and export of flowers and flower bulbs was already important in the 17th century, breeding in floriculture was only done on a very small scale. Breeding in vegetables was done by a number of small companies, mostly family holdings. It was the government who funded research in breeding to enable the development of new varieties by the establishment of a plant breeding research institute in the 1940s. The aim was to carry out strategic research and to develop pre-breeding material to be further developed by private companies, both for vegetables and floriculture. Soon this strategic work became a public-private activity.

For those crops where no private entrepreneurship in breeding existed, e.g. apples and strawberries, the government financed the entire breeding programme, including the release of new varieties. The latter resulted in successful varieties for these crops like Elsanta for strawberry and Elstar for apples, both having a substantial market share in Western Europe.

The unique position and leading role of breeding in vegetables is also shown by the fact that eight out of the ten largest breeding companies in the world have either their headquarters or a large breeding station in the Netherlands. These ten companies provide almost 80% of the world market with vegetable seeds.

Almost all breeding companies have their own biotechnological research units. A number of them have joined efforts in this field and established Keygene as a research facility in Wageningen. This laboratory is known for their work on genetic marker technology, notably on the development of the AFLP technology. Vegetable breeding companies are spending about 15% of their return on R&D.

The flexibility of this breeding sector was proven when in the early 1990s the export of tomatoes to Germany dropped due to bad quality of the harvested products. In only a few years this crisis was completely overcome by introducing new, more tasteful varieties that currently dominate the European market.

Production of mushrooms in the Netherlands is of a rather recent date. In 1957 the experimental station was established and soon there was a close cooperation between growers and the station. Education, extension and research were concentrated in one place. When in the 1970s the market almost collapsed, researchers of the station developed new high-yielding varieties. In combination with improved mechanisation, the crisis was overcome. The same holds for the production of compost, where bad smell caused problems in the area. Staff of the experimental station assisted in solving this problem by discovering the cause of the bad smell production.

Breeding in cattle has been done since the mid-19th century by farmers. In the 1870s, cattle syndicates were formed to follow pedigrees from various bulls. With the import of Danish breeds in the 19th century and of American breeds in the 1970s, new inputs were given into the breeding programmes. Another breakthrough was the use of computers to carry out statistical research: much larger groups of pedigrees could be followed. With the introduction of artificial insemination, embryo transplantation and distribution of sperm in a frozen state, even more technology was put into the breeding programme. Nowadays, the Dutch cooperative for cattle improvement (CR Delta) ranks fourth in the world in distributing sperm to more than 50 countries.

Cheese production and diversification in dairy products was greatly stimulated by research at NIZO, the combined R&D facilities of the dairy industries. Earlier, standardisation of methods of cheese production and development of new cheese types had a significant positive effect on the cheese market. This also applies for the improved processes in butter production and the search for wider applications of milk powder. Furthermore, the high standard in food safety and hygiene was and still is due to the activities of NIZO. Nowadays NIZO Food Research supports innovations by providing functional improvements that underpin emotional benefits in a wide range of ingredients and consumer products.

Further, the research on biological control of pests and diseases should be mentioned. Research on biological pest control started at Leiden University, Wageningen University and at a Horticultural Experimental Station in the 1950s. In the beginning, this research was coordinated by TNO. The results of this research are widely used in agricultural practice, notably in crops grown in glasshouses. At Wageningen UR, biological control of pests and diseases is still an important and well-recognised part of their research.

Biological control of fungal diseases started in the Department of Phytopathology of the universities of Utrecht and Amsterdam: the Willie Commelin Scholten Foundation. In the 1990s this was largely taken over by the Research Institute for Plant Protection (IPO) in Wageningen and the University of Utrecht after closure of the laboratory of the above-mentioned foundation.

The wider application of biological control of pests and diseases in commercial holdings was mainly the result of private enterprises, as the companies 'Koppert', 'Green Fly', 'Entocare' and 'Brinkman'.

As a result from the enormous growth of production of flowers and vegetables in glasshouses, the glasshouse building industry developed into a very innovative industry, building various types of glasshouses in the Netherlands and abroad. Both climate control and automation are part of these innovations.

Nowadays, agriculture in the Netherlands comprises much more than primary production of various crops. Some large economic sectors have rapidly developed at the end of the 20th and early 21st century:

- Tree nurseries (mainly for export)
- Horse breeding and husbandry
- Landscape development (e.g. national parks, nature management)
- 'Green care' farms (accommodating mentally disabled people)
- Recreation farms (e.g. farms with small camp sites).

The developments of these rather new branches rely for a significant part on the agricultural knowledge infrastructure in the Netherlands.

In contrast, aquaculture did not achieve the earlier expected success in replacing traditional farm activities.

FINANCING RESEARCH BEFORE 1987

Experimental stations

As stated before, much of the *applied research in horticulture* started with demonstration gardens in the production centres for vegetables, flowers and fruits. As these were private foundations, funding was obtained from growers, either individually ('membership') or through their organisations. The sale of products was also an important source of income for these gardens. Public funding occurred when teachers of specialised horticultural schools became involved in experimentations. Later, regional civil authorities also supplied some funding.

During the existence of demonstration gardens, funding developed in a public-private partnership, which reached a ratio of 50–50%.

The same holds for the experimental stations, where soon a 50–50 share was established between public and private funding. Private funding was obtained by a levy on sales through the auctions and also by a levy on the amount of hectares of a specific crop, e.g. cereal production. This situation remained until the 1990s. Since then, growers are obliged to pay a levy on either sales or hectares per crop to the 'Commodity Boards'. These Commodity Boards invest part of this money in research programmes, conjointly formulated with the ministry and the researchers.

Applied research on *bulbs* started by public funding, since the Bulb Research Centre in Lisse was part of the Wageningen College of Agriculture. A 50–50 ratio between public and private funding occurred when the Bulb Research Centre was disconnected from Wageningen University and received the status as an experimental station in 1965.

For *applied research in agriculture, including animal husbandry*, funding was primarily by public funds. The (few) experimental stations were public-funded and only the existing demonstration farms had both public and private funding. For the experimental stations, established in the 1970s and 1980s, a 50–50 ratio in funding by public and private funds was obtained around the 1980s. Until then, the government primarily financed research.

Research institutes

From the beginning of the research institutes, the Ministry of Agriculture paid a yearly lump sum, to finance the total research programme. Buildings and their maintenance were financed by the government in a separate way. This situation lasted until the 1980s. With a decreasing research budget from the Ministry of Agriculture, the research institutes acquired more projects from other funding agencies and merged into larger units, so reducing overheads. Gradually, payments were made based on research programmes, with a certain percentage for strategic research. Draft proposals of these programmes were first discussed with the Ministry and after having their agreement, financing took place.

Research to fulfil statutory tasks, e.g. on food safety, were financed separately by the Ministry.

WAGENINGEN UNIVERSITY

As stated above, Wageningen University is part of the Ministry of Agriculture, but financing is based on the same principles as for other universities since the establishment of the Academic Education Act. Additional income was obtained via projects, financed by different funding agencies. From the 1970s onwards, this was primarily the Netherlands Organisation for Scientific Research (NWO). Later on, other agencies were also an important source of funds, like the European Union and other foundations.

In the late 1980s a substantial amount of money from the core funding of all universities was transferred to the Netherlands Organisation for Scientific Research. The already existing competition for obtaining funding from NWO for fundamental research projects or programmes became more important and more intense. This funding is called the '2nd funding source'. The '3rd funding source' is the total of all other income obtained in competitive – nationally and internationally – funds both from governmental bodies and private industry.

DEVELOPMENTS SINCE 1987

Concentration of strategic and applied research activities

In the second half of the 1980s, the Minister of Agriculture proposed a new plan for the further development of the research institutes and the experimental stations to the parliament. This plan (1987–1990) was the result of long discussions with the various stakeholders during the preceding years. By merging various

discipline-oriented research institutes, overlapping activities were avoided and a more efficient organisation could be obtained. As a consequence, an almost continuous process of concentrating of research institutes and experimental stations took place between 1987 and 2001. At the end of this process, only seven research institutes remained, namely Plant Research International, Research Institute for the Green Environment, Agricultural Economics Research Institute, Institute for Animal Research, Research Institute for Agro-technology & Food Innovations, Central Institute for Control of Animal Diseases and the Institute for Food Safety.

The number of experimental stations was reduced to two, which are 'Applied Plant Research' and 'Applied Animal Research'.

Another important reorganisation took place in 1989. The (overall) directory of the research institutes was split into two bodies: on the one hand the Directory for Science and Technology within the ministry, responsible for research policies and financing, and the research executing Agricultural Research Service (DLO) on the other hand. In this way, public funding of research by the Ministry of Agriculture was done through one of its directorates, while the research-executing organisation was not directly involved in science policy. This was also the beginning of another type of research financing.

In the 1990s, the Agricultural Research Service (DLO) became a separate foundation: the Foundation for Agricultural Research, covering the agricultural research institutes and the two existing experimental stations.

The most revolutionary change took place in 1999, when the Foundation for Agricultural Research was privatised, and became a contract research organisation. From then on, staff working for this organisation no longer had a status as civil servants. The governmental role of the Ministry of Agriculture was reduced to the appointment of a 'Supervisory Board', responsible for the correct management by the Board of Executives of the Foundation. A yearly fixed budget of the ministry was allocated to the Foundation for Agricultural Research. However, the way in which this money could be spent changed dramatically over the last decade (see below).

DLO: from supply-driven to demand-driven

The procedures to decide on research topics have changed greatly during the last two decades.

In the period between 1990 and 1995, all research projects were grouped into research programmes. These programmes roughly overlapped with the various research groups in each research institute. Financing by the Ministry of Agriculture remained on an institute basis, while an increasing number of projects were financed by other agencies.

In 1996, the Ministry started financing the full costs of research programmes instead of institutes. The financing of research programmes was for a period of 4 years. However, on an annual basis the financial support could be changed, and in most cases was reduced. Each research programme was supervised by a

steering committee. Members of these committees came from the most relevant directorates of the Ministry and from other stakeholders.

The research programmes could be classified into two categories: 'research to support the agricultural sector' and 'research to support policy'.

From 1998 onwards, most of the research programmes are spread across institutes, i.e. the entire programme consists of projects in which several institutes participate. Then the budget was divided into 10% for strategic research and 90% for research to support policy. This was later followed by allocation of 5% of the research budget for open calls for research proposals also from other research institutions than the DLO institutes.

In 2003, the Ministry decided that money allocated for research should be divided and spent over four categories: (1) basic or core funding 20%; (2) research to support policy 40%; (3) statutory tasks 25%; and (4) open call and incidental projects 15%. The research for statutory tasks is financed by long-term contracts.

Each research programme is evaluated on the basis of a number of criteria, such as quality of the output, application of knowledge by users, efficiency of input, relevance for the Ministry's policy and for society.

The consequences for DLO of being a contract research organisation

The research institutes and the experimental stations are free to acquire additional finances by carrying out research for other bodies or agencies than the Ministry of Agriculture.

Of the total budget, about 45% is obtained from sources other than the Ministry of Agriculture. Although this Ministry is paying the full costs of research programmes, other parties, like the European Union, demand investments by the institutes in funded projects through 'co-financing', sometimes up to 50%. This is a complicating factor in the annual budgeting of the institutes. Moreover, most research institutes have to cope with an annual renewal of one-third of their contract portfolio.

THE FORMATION OF WAGENINGEN UNIVERSITY AND RESEARCH CENTRE

In the 1990s it became more and more apparent that the linear research model that distinguished basic or fundamental – strategic – applied research had evolved into an iterative participatory research model. In this new model the different types of research participated within one research programme. It also became clear that a strategic improvement of knowledge chains and networks was necessary in a more competitive research environment. These were the main reasons for the establishment of the Wageningen University & Research Centre (Wageningen UR).

In 1997, the formation of the Wageningen UR started by merging the two executive boards of the university and the DLO organisation. One year later, the name of the Wageningen Agricultural University was changed into Wageningen University.

Although agriculture was, and still is, a significant part of the university's education and science programme and also the principal source for many research questions, other subjects like food and health, human consumption, biotechnology, genomics, geographic information systems, microbiology and nanotechnology became increasingly important and more dominant. Moreover, the influence of the primary sector on the research programme diminished during the last decades.

Wageningen UR now has five Sciences Groups: Plant Sciences; Animal Sciences; Environmental Sciences; Agro-technology & Food Sciences; and Social Sciences. Each of these groups covers both education and research, fundamental, strategic and applied research.

For supporting and executing statutory tasks, two separate institutes remain: the Central Institute for Control of Animal Diseases (CIDC) and the Institute for Food Safety (Rikilt).

Since 2003, each science group has formulated its own strategic plan.

In 2004 the existing College for Agriculture & Environment (Van Hall-Larenstein; located in other cities in the Netherlands) merged with Wageningen UR.

Gradually, the entire organisation is becoming one institution with a great flexibility, ready to react quickly on changes in student numbers and the research market.

FINANCING OF WAGENINGEN UR

Wageningen UR is financed in different ways. The university is paid according to the overall rules for universities. The core funding is based on the number of students and the number of Ph.D. graduates (1st financing source). In addition, competitive grants are obtained from the Netherlands Organisation for Scientific Research (2nd financing source).

Together with the other partners in Wageningen UR, competitive grants are obtained from different sources, like private industries, other Ministries than that of Agriculture, from the European Union and the World Bank.

Wageningen University & Research Centre is quite successful in obtaining additional grants next to its core funding. The strategic and applied research part of Wageningen UR viz the DLO institutes obtains approximately 45% of its turnover from other sources outside the Ministry of Agriculture. The university part of Wageningen UR has three times more staff than are financed by core funding alone, by being successful in acquiring competitive grants (see Fig. 2).

Innovating the agrifood sector

Another major change since 1987 is the gradual disappearance of the EER tryptich (see above). The Agricultural Extension Service of the Ministry of Agriculture was privatised and as a result almost disappeared. Private consultants and the agrochemical industry took over part of the extension work. In addition, other ways of implementing research were found. For example, front-running farmers became involved in experiments, supervised by and in

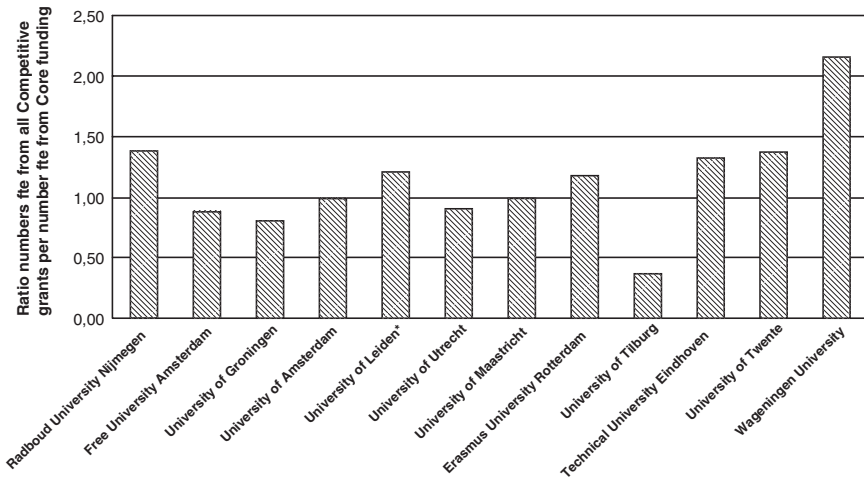

Figure 2. Relative performance of Universities in The Netherlands regarding rewarded competitive grants. (Source: Netherlands Association of Universities, 2003;

*Univ. of Leiden, Faculty of Med. Sci. calculated from data Min. Education & Science, 2003).

close cooperation with researchers from experimental stations or research institutes. Sometimes the Ministry established temporary agencies to promote and implement the desired innovations in agriculture. These agencies obtain funds to bring together the different stakeholders involved in the entire food chain and to finance the research needed to achieve the desired developments.

Nowadays, innovations in agriculture do not appear according to the linear model (fundamental research – strategic research – applied research – extension & education – agricultural practice), but in a far more diffuse manner (see also Leeuwis et al, 2006). Recently, this complex process is often managed and facilitated by temporary agencies (such as ‘Innovation Network’, and ‘Transforum’) and also by private consultancies and by experimental stations or research institutes.

By using the food-chain approach, research programmes were formulated and innovations later on implemented.

Concentrating research and development: the ‘agrifood valley’

In the late 1990s, eight food industries, together with the Ministry of Economic Affairs, established and financed a ‘Technological Top Institute’: ‘Wageningen Centre for Food Sciences’ (WCFS). This centre finances a substantial part of fundamental research at Wageningen University and at some of the research institutes. Next to that, Wageningen was successful in attracting some other R&D divisions of industries within its city borders, e.g. Numico Research, Campina and Seminis Vegetable Seeds.

The city dedicated a separate area as an agro-business park. In a cooperative effort, the province of Gelderland, the city of Wageningen, Wageningen UR,

some surrounding cities with multinational food industries, established the Foundation 'Food Valley'. This foundation stimulates food-related industries to invest and concentrate their R&D activities in Wageningen.

In 2003, the centre for Biosystem Genomics was founded, financed in part by the government and by a consortium of breeding companies.

Two years later, the Dutch government asked for an analysis in which key areas it could invest best, in order to stimulate its strongest and most promising economic drivers. This analysis concluded that there are four such key areas in the Netherlands, with the Flower and the Food industries as one of these. Also based on this analysis, it resulted in 2006 in the establishment of a public-private funded initiative: the 'Green Genetics Institute', with a budget of €40 million.

In 2005, the total staff of Wageningen UR was approximately 5,000, while about 2,500 staff were employed by private companies, also located in Wageningen, the smaller ones often using laboratories of Wageningen UR.

In 2001, at a conference on innovation at the Ministry of Economic Affairs, M. Porter (Harvard, USA) gave a keynote address. He critically noticed that there are *'too few linkages between clusters of industries and universities due to the structure of most Dutch institutions for higher learning. The only exception to this is the Wageningen University and the agricultural based clusters.'*

FUTURE OUTLOOK

The integration of experimental stations, research institutes, university and vocational education into one large organisation took place in the early years of the 21st century. The strict division of various types of research, that is fundamental, strategic and applied research, was no longer applicable. An iterative participatory knowledge model increasingly replaced the linear knowledge model. The traditional role of separate experimental stations, research institutes and the university became obsolete and that was the major reason for the big integration and merger process.

The structural change in the organisation in itself is not sufficient for a renewal of the innovation system. The attitude and culture within the knowledge institutions and the intensification of the interactions between stakeholders and the scientific community is a primary requirement. The creation of an enabling environment is only a first step.

In fact, there is an urgent need for a dramatic change in the agricultural knowledge system for three reasons:

1. To stay competitive, the renewal of products, production processes and production systems requires upgrading and updating of the structure and mode of operation, both in agriculture and in the various production chains.
2. The financing of research is more and more a common responsibility of public and private sources, but the latter requires an appropriate system of accountability.

3. Sustainable development as a broadly shared objective for all stakeholders requires a different way of operation in the knowledge system.

There are several efforts at this moment to attain such a change. The intensification of contacts between various actors in the production chain, initiatives of some multinational food firms in the sustainable 'Agricultural Initiative' and the general conviction that a renewal of the societal contract of the agribusiness is needed. This leads to the conclusion that structure, as well as culture and mode of operation have to be changed.

What the typical characteristics of that new structure will be is not yet exactly known, it is however clear that there is not one fixed structure. Flexibility is needed and there are various organisational structures possible. In all cases the involvement and commitment of all stakeholders is needed. And in all structures there should be a clear research-agenda-setting body having less procedural certainty but with more active and well-defined intermediates.

The culture in the production organisations and in the knowledge institutions requires a more open attitude to the primary producers. Improvement of direct contacts and a clear and open attitude towards co-innovation will undoubtedly be very helpful.

The mode of operation is less fixed and more flexible. That requires a more responsive environment, a better financing system and a solid core funding of the knowledge institutes. The role of intermediate structures, i.e. between universities (primarily responsible for fundamental research) and the institutes for applied research or the R&D divisions of industries should be investigated and upgraded.

Science and technology in general, but agricultural research in particular, must create a greater appeal for young scientists. In order to keep a strong knowledge system, career perspectives in agrifood research need to be re-established.

A further concentration of R&D divisions from agrifood industries in the direct periphery of or within the knowledge institutes themselves, is needed to secure the critical mass and achieve optimal use of the infrastructure facilities. In this regard the Food Valley concept has proven to be successful so far, but the energy investment to sustain current developments needs to be maintained.

CONCLUSIONS

As a result of a strong interaction between various stakeholders in the agricultural production chain, co-financing of research and co-innovations, a strong and competitive agricultural industry has developed in the Netherlands.

The role of the government has been to facilitate developments in the various agricultural activities.

In a number of activities, the Netherlands still has a leading position in the world.

The traditional separation in fundamental, strategic and applied research has become obsolete, which led to a reshuffling in the agricultural knowledge organisation and a merger into the Wageningen UR.

Financing of agricultural research changed dramatically in the sense that the government reduced their allocations for research in general, directing research questions only for guiding or for support of their own policy. The primary sector largely discontinued their support for experimental stations and mainly supported applied research for the short term to solve their problems and much less for the long term to obtain innovations.

Public-private funding of research is becoming important, whereby research proposals in the field of agriculture are not only obtained from the traditional agricultural research establishments.

Mono-disciplinary research has been gradually replaced by multi- and interdisciplinary research in which staffs from both social and life sciences participate. This type of research can often better be characterised by consultancy than by strategic research. By this development the niche for particular expertise can hardly be distinguished and borders between private consultancy agencies and the research institutes disappear in some fields.

A research institute for strategic research should remain focused on studying the scientific feasibility of politically desired developments. Hence strategic research is legitimated by the indispensable link between fundamental science and demands from society. For individual researchers it is this double-focus that challenges them. During the past decades, a third competence was introduced on top of the other two: a commercial attitude.

It is remarkable that although the issues studied always have links with questions generated by agricultural practice, *the output meets internationally recognised scientific standards*, as reflected by the number of articles in refereed journals for fundamental research (and frequently those with high impact factors).

For a privatised contract research organisation, acting for a great part in the public domains, sufficient core financing remains important. Not only to carry out long-term research, both fundamental and strategic, but also to finance research programmes obtained from other funding agencies, where co-financing is requested, like research programmes from the European Union.

ACKNOWLEDGEMENTS

We thank our (former) colleagues for providing useful information. In particular: Mr. B. Barenbrug, Dr. R.J. Bogers, Prof. Dr. Ir. P. Brascamp, Dr. Ir. J. Dommerholt, Prof. Dr. Ir. L.J.L.D. van Griensven, Dr. Ir. A. Kuipers, Ir. C. D. van Loon, Ir. J. P. van Loon, Dr. Ir. O.M. de Ponti, Dr. Ir. K. Reinink, Ir. G.S. Roosje, Ir. A. van der Schaaf, Dr. Ir. P.K. Schenk, Dr. Ir. J.M van Tuyl, Dr. Ir. G. Weststeijn, Dr. Ir. W. de Wit, and Dr. J.N. de Vries. We also thank Prof. Dr. K.E. Giller for improving the English language of our manuscript.

REFERENCES

- Annual Report of the Association of Netherlands Universities (VSNU), 2003.
- Benda, H.A. 1967. Weten en laten weten. Honderd jaar onderwijs, voorlichting en onderzoek in de landbouw. Ministerie van L&V, Den Haag.
- Braks, G.J.M. 1987. Landbouwkundig Onderzoek in perspectief, ontwikkelingsplan voor de instituten en proefstations van het Ministerie van Landbouw en Visserij, 1987–1990.
- Leeuwis, C., Smits, R., Grin, J. Klerkx, L., van Mierlo, B., and Kuipers, A. 2006. Equivocations on the post privatization – dynamics in agricultural innovation systems. *Transforum Agro en Groen*. In "The Design of an Innovation-enhancing Environment". in Working papers no 4, Transforum, Zoetermeer, the Netherlands.
- Maat, H. 2001. Science cultivating practice. Ph.D. thesis, Wageningen University, Wageningen, The Netherlands.
- Maltha, D.J. 1976. Honderd jaar landbouwkundig onderzoek in Nederland 1876–1976. Pudoc, Wageningen, The Netherlands.
- Newsletter, Ministry of Science and Education, March 2003.
- Poel, J.M.G. van der, 1949. *Heren en Boeren*. Ph.D. thesis, University of Groningen, The Netherlands.
- Porter, M.E. 2002. Innovation and competition: findings on the Netherlands. Ministry of Economic Affairs, The Hague, The Netherlands.

CHAPTER 18

AGRICULTURAL RESEARCH IN ISRAEL

G. LOEBENSTEIN AND E. PUTIEVSKY

Agricultural Research Organization, Volcani Center, Bet Dagan 50-250, Israel

HISTORICAL

The beginning of agricultural research in most countries was based on a tradition of farmer's experience. In Israel – or Palestine as it was in the 19th century – the farming communities were mainly the Arab fellah type of dry farming, as practiced for more than 2,000 years, on a subsistence level. More so, not only advanced farming knowledge was lacking, but also the first Jewish settlers were lacking any agricultural experience.

The forerunners of agricultural research in Palestine can be seen around 1870 (at that times part of the Ottoman empire) with the founding of the Miqve Israel agricultural school (http://en.wikipedia.org/wiki/Mikveh_Israel) where introductions of many fruit and garden crops were evaluated. When the first Jewish agricultural villages were established in the last two decades of the 19th century experimental plots for fruit and garden crops were allocated in each village. These plots were under the supervision of an agronomist and the village council confirmed the work plan (Oren, 1993). This was a necessity as these villages were based mainly on horticultural crops, as grapes, citrus and almonds, while in the Arab villages agriculture was of a dry farming type with barley, chickpeas, sesame and olives predominating. The few German Templer villages were based on relatively large farms of dry farming of wheat and barley (Tirel, 2006).

After the Balfour declaration by Great Britain in 1917 (http://en.wikipedia.org/wiki/Balfour_declaration) and the award of the mandate to Palestine by the League of Nations to Britain, the Jewish Agency (http://en.wikipedia.org/wiki/Jewish_Agency) established in 1921 the Agricultural Experiment Station. Their mission was to conduct research leading to a small farm with an intensive type of agriculture, specializing in mixed farming of fruit trees, cattle, chicken, vegetables and cereals. The research station, headed by I. Elazari-Volcani (www.agri.gov.il/Units/Spokesperson/Heritage/About.html) and located in Rehovot, was the first scientific institute in Palestine, had departments for crop sciences, fruit and

citrus, soil and irrigation, entomology and plant pathology, post-harvest, food technology and farm economics. The station had an extension department and results were quickly diffused to the farmers. Results were spectacular. Yields of grain under dryland conditions increased from 600 to 5,000 kg per hectare; and breeding and selection of cattle increased milk production from 800–1,500 kg to 5,000 kg/cow/year (1950) (now more than 11,000 kg/cow/year – 2005). Research in storage of citrus fruit reduced spoilage during shipping to Europe due to fungal rots from 30% to 2–3%.

In 1942, Hebrew University in Jerusalem (<http://www.huji.ac.il/huji/eng/>) decided to establish the Institute for Agricultural Studies, which later developed into the Faculty of Agricultural, Food and Environmental Quality Sciences (<http://www.agri.huji.ac.il/>). In the beginning the faculty staff came mainly from the Agricultural Experiment Station and students worked on their theses in the laboratories of the Station.

In parallel the British government established a small agricultural research section with several stations in both Arab and Jewish areas. After 1948 with the establishment of the state of Israel, the two research stations – the one established by the Jewish Agency and the other by the British, were merged into the Agricultural Research Station within the Ministry of Agriculture. However, the extension and advisory service, previously part of the research station, became now an independent branch within the Ministry.

In 1960 an attempt was made to merge the Agricultural Research Station with the Faculty of Agriculture of the Hebrew University into the National and University Institute of Agriculture. Though the idea was excellent (based on the US model of the Land Grant Colleges) it failed completely because the basic working conditions were not equalized before the merger. Nevertheless, a close cooperation exists between the two institutions and the senior researchers of the Agricultural Research Station serve on the teaching staff of the Faculty and students from the Faculty do their research for M.Sc. and Ph.D. theses at the Research Station. With the growth of the various disciplines in the Agricultural Research Station and the establishment of regional research stations, the organizational structure changed somewhat, establishing in 1971 the Agricultural Research Organization (ARO), incorporating all agricultural research within the Ministry of Agriculture.

THE AGRICULTURAL RESEARCH ORGANIZATION (ARO)

The mission of the ARO over the years was and is to serve the development of the Israeli agriculture by an efficient use of the limited water resources, development of crops for export markets, ensuring a decent income for the farming community, developing and adapting crops and technologies for newly settled regions, all this with care to the environment. Within the ARO (<http://www.agri.gov.il>) are six institutes, two commodity (Plant and Animal Sciences) and four discipline-oriented institutes (Plant Protection, Soil, Water and Environmental

Sciences, Technology & Storage of Agricultural Products and Agricultural Engineering). The ARO has two additional research centers – Gilat, in the Southern part of Israel and Neve Yaar in the Northern part.

Within the six institutes the various scientific departments (see <http://www.agri.gov.il>) cover all agricultural disciplines except veterinary sciences. In addition to the Institutes the ARO maintains a computer unit, Genomics and Bioinformatics section, technology transfer (engaged in business related activities), international activities, youth activity units and a library.

The Veterinary Institute of the Veterinary Services of the Ministry of Agriculture is also located on the central campus of the ARO.

Institutes, departments and staff

Institutes are organized in accord with scientific disciplines and around common subjects. The Institute provides administrative and certain other services (maintenance, transport) and organizes seminars. The head of the Institute is a member of the ARO's directorate and represents the Institute in major management forums. The Head of the ARO appoints him after being elected by the senior researchers of the Institute, for a term of four years. This system is probably not the best one as heads of institutes are sometimes elected not because of their leadership qualities, but due to the wish of the researchers to have an "easy going" director. It would probably be advisable to appoint heads of institutes by the Head of ARO and his directorate and subsequent approval of the scientific committee of the Institute's researchers.

The head of the Institute should coordinate work between the departments; initiate research teams, also with research groups from other institutes and solve personnel and other problems. But as he has almost no funds at his disposal his initiatives are limited to his leadership abilities and persuasions.

Departments are centered on a common discipline or subject. They provide services to the researchers as greenhouse maintenance, acquisition of expensive equipment, media preparation, etc. A minimum of researchers is required for a department to operate efficiently and if their number falls below a certain level (10–15) it is advised to merge it with another department. The department has timely seminars and journal clubs, and discussions of the ongoing and future research projects, allocation of rooms and greenhouse space and proposals for acquisition of joint equipment. It is highly recommended that researchers and technicians meet once a day for an informal coffee break, where all kinds of topics (and gossip) are brought up. This is imperative for the operation of the department.

The researchers elect heads of departments for a three-year term that can be extended to four years, with an option to another term. However, it would be advisable that heads of departments be appointed by the Head of the ARO and the Head of the respective Institute and approved by the committee of senior researchers of the department. The candidate should be an outstanding

researcher, with broad general knowledge of the department's research area, up-to-date with recent scientific literature, familiar with the agricultural system and leadership qualities. He has to be open to the other voices and willing to hear constructive criticism.

Research staffs are recruited after a public announcement in local and international journals. The candidates should present detailed curriculum vitae and give a seminar on their recent work. Recently, when appointed he receives from the director of the ARO a two-year research budget, which allows him to develop his research program, and not to spend all his time for writing grant applications. A permanent appointment starts after the candidate reaches a rank equivalent to senior lecturer at the universities. The researcher's appointment defines his position within the department together with a job description. The researcher develops his research program according to his job description, inclinations and available grants. He is free to a certain extent to divert from his original task to where grant funding is.

Two committees are handling promotions. The first one, headed by the director of ARO, or the deputy director for research, screens the applications (from the candidate or his supervisor) and requests outside reviews from senior scientists in Israel and abroad from first class universities or research institutions. The evaluation from the referee has to include a sentence that "the candidate is well qualified to be appointed in my university at the respective grade".

This system which ensures that promotions are handled in a more or less impartial way, places however emphasis on publications in high impact journals. In addition, the promotion committee's evaluation is based on additional criteria as international activities (invited lectures, book chapters, invited reviews and competitive grants), practical achievements (including national competitive grants, publications in farmer's and technical journals, reports) and teaching and supervision of students.

In addition to the permanent research staff, a relatively large number of students for M.Sc. or Ph.D. degrees are active within the departments. They perform their research work under the supervision and guidance of ARO's researchers (who are accredited by a university) or under joint guidance with a university researcher. The university awards the degree. Their salaries are paid from the research grant of the ARO researcher or from a special fellowship fund of ARO. An M.Sc. degree generally requires two years of experimental work and for a Ph.D. between three and five years. Recently (2003/2004) the Ministry of Agriculture established a scholarships fund for a program entitled "The Whole Organism". These scholarships will be awarded to excellent students devoting themselves to studies of the "Whole Organism" either for an M.Sc. or Ph.D. degree.

Determining research priorities and sources of funding

Up to 20 years ago priorities for research were determined by a committee of the Ministry, headed by the Director of the ARO, comprised representative from the

ARO, Extension Service, the Planning Authority of the Ministry and scientists from universities. After separating the function of Chief Scientist from that of the Director of ARO, the responsibility to determine priorities for the research fund provided by the Ministry, lies with the Chief Scientist. He operates with the help of the General R&D Council, an executive council, the scientific evaluation and steering committees. The latter, comprising a third of each researchers, extension and farmers, suggests the research needs, priorities and budgets for each field. The Scientific Evaluation Committees (SEC) (for the main scientific areas) are comprised of scientists from various academic institutions, often including extension specialists. They evaluate the scientific quality of the research proposal. The proposal includes a scientific and an applied background, detailed research plans including a time schedule, personnel and their qualifications, previous work done, detailed budget and relevant literature. Proposals are sent to reviewers, internal and external, sometimes also abroad, and decisions are based on reviewers' comments and knowledge of the members of the committee. Projects are generally for three years. The scientist is required to submit each year a brief progress report and at the end of the project a detailed report. In addition, scientists present their results in seminars, before growers, in meetings of professional societies and in the scientific and technical (growers) literature.

The present main objectives of the public funded research are: supply of fresh food products all the year around at reasonable prices; increasing exports of agricultural products; strengthening the farming community at the periphery of the country; increasing production and income of farmers; efficient use of the limited water resources and precision agriculture. These goals require development of new products and cultivars, improvement of food quality and safety, functional food, integrated pest management (IPM), precision agriculture and farming efficiency, with agricultural technologies friendly to the environment.

The fund of the Chief Scientist is open to scientists from all institutions – ARO, universities, regional research organizations, extension specialists and farmers.

In addition to the Chief Scientist's fund, the various commodity branches, as vegetables, flowers, fruits, dairy cattle, etc. allocate research funding of direct interest to them. The Minister of Agriculture, upon recommendation of the Chief Scientist, appoints the committee members for research in each commodity branch. In general a third of the members come from the scientific community, a third from the extension service and a third are farmers. The proposals submitted to the commodity branches also undergo the scientific evaluation process.

However, funding for each project is often inadequate and does not allow a thorough investigation. It also results in a too high number of projects that each researcher takes on himself (to cover the costs of technicians, students, etc.) and a waste of his time in writing proposals and reports for each of the projects.

A substantial source of funding, mainly for more basic research, comes from binational funds. The leading one is the USA – Israel Binational Agricultural

Research and Development Fund (BARD). BARD is a competitive funding program for mutually beneficial, mission-oriented, strategic and applied research of agricultural problems, jointly conducted by American and Israeli scientists. Since 1979, BARD has funded over 870 research projects, with awards of about \$9.5 million annually for new research projects. Most of these are of three years duration, the average award being \$300,000. Budgets are distributed about equally between the two countries. Proposals are evaluated both in the USA by the Agricultural Research Service (ARS) and in Israel by the Scientific Evaluation Committees (SEC), based on expert reviewers from different countries. The recommendations from ARS and SEC are brought before a Technical Advisory Committee (TAC) for final recommendations to the Board of BARD. Among the research areas funded were: Alleviating Heat Stress in Dairy Cattle, Breeding for Heat Tolerant Wheat Varieties, Improving Wheat-Seed Proteins by Molecular Approaches, Algal Culture and Improving Cut Flower Quality to name only a few where significant results were obtained (BARD, 20-year external review, <http://www.bard-isus.com/mission.htm>). The success of BARD led to the establishment of additional binational funds as the Joint Dutch-Israeli Agricultural Science and Technology Program, a binational Program with Queensland (Australia) and Canada. The latter are all on a much lower funding level than BARD. In addition funding is also obtained from the EU, The US–Israel Binational Science Foundation (BSF) and others.

The scientists generally initiate projects. Sometimes heads of institutes or the director of ARO will propose high priority research projects to a scientist or a group of scientists. This will generally be an area requiring a multi-team approach. Extension specialists also often contact researchers to suggest research related to their expertise.

Recent constraints

During the last 15 years a severe cut in the overall allocations for the regular permanent budget from government sources occurred. This was due to a shift in priorities from agriculture to high tech areas as electronics and software programs. Agriculture at present although with a high per capita income from exports has reached a plateau and research is important to keep the exports at its present level. Positions for technicians and administrative help were cut, funding for electricity and maintenance in the regular budget were sharply reduced and had to be covered from overheads on grants. The result from the standpoint of the researcher was that he had to spend an inappropriate part of his time in search for grant money, which were not sufficient to cover both the overheads and the direct costs of his research. More so, as local grants were small he had to commit himself to several projects, each of which was underfunded. The “hunt” for grant money from private sources and funds interested in cooperation with developing countries diverted some of the research effort to those areas, which were not always of high priority to Israeli agriculture. It also did not enable management at the departmental or intuitional level to pursue a balanced research program.

From a personal view basic needs required for the research operation as maintenance of buildings should not be covered from grant money, but by the Institute's regular budget. Grant funding should be less than one-third of the total operational costs (including salaries of the permanent staff) of a research unit, and overheads on grants should not exceed 25%.

While preparation and evaluation of research proposals is more than adequate, evaluation of results should be improved. Though some of the review is done when the scientific evaluation committee considers a new proposal or a renewal of the project, the general evaluation of projects should be strengthened.

Increase in future government (or business) allocations can only be expected if breakthroughs enabling major novelties in agricultural products can be developed, and/or new technologies in agricultural practices, as precision agriculture or functional food can be established. Thus, for example, if technologies will be developed whereby plants (or animals) can serve as bio-reactors for producing high value medical or industrial proteins. This could start a completely new agro-industry combining production of the high value compounds by farmers and their purification and evaluation by industry.

However, not only inadequate funding is at the base of creating new breakthroughs. Israel's agricultural research, which was in the forefront, worldwide, in drip irrigation, fertigation, plasticulture, new fruit and vegetable crops as avocado, sweet peppers, fresh herbs, tomatoes and a variety of ornamentals; biological control of pests and IPM, etc. loses its leadership. Its funding structure should allocate a major part into high priority areas, thereby concentrating available resources in a more efficient way, instead of spreading it out thinly into too many subjects.

Other constrains relate to the organizational structure of the ARO. The ARO is presently a part of the Ministry of Agriculture and as such has to operate within the government regulations and restrictions. This curtails the freedom of ARO's management and often hampers the smooth operation of the research projects. On the other hand changing the status of ARO to a semi-autonomous organization may lead to a further substantial cut in funds allocated by the government.

AGRICULTURAL RESEARCH IN UNIVERSITIES

The Faculty of Agriculture, Food and Environmental Quality Sciences of the Hebrew University in Rehovot is a major partner in the conduct of agricultural research. In the Faculty, which includes agricultural economics and management, a school of nutritional sciences and hotel, food and tourism management are about 90 tenured scientific staff. The major scientific disciplines are: Agricultural Botany; Field Crops, Vegetables and Genetics; and Horticulture; Biochemistry, Food Science and Nutrition; Entomology and Plant Pathology; Soil and Water Sciences; Animal Sciences; Veterinary Medicine and Agricultural Economics and Management (<http://www.agri.huji.ac.il>). The Faculty has a student body of about 2,300 students.

Roughly, scientists of the Faculty do about 25% of the agricultural research in Israel. Additional research on a limited scale is carried out at Tel Aviv University, Bar Ilan and Ben Gurion universities and at the Weizmann Institute of Science.

REGIONAL RESEARCH

Several regional research centers are operating, the major ones being the Northern R&D, Southern R&D and the Arava Valley R&D. They are partially funded by the Ministry of Agriculture, the Jewish Agency and Keren Kayemeth LeIsrael (Jewish National Fund). Researchers from the ARO, the Faculty of Agriculture, Ben Gurion University and others are actively involved in research projects carried out within the Regional R&D centers. A senior researcher from the ARO generally acts as the scientific director in each regional center, and an ARO scientist coordinates all regional research. Their main goal is to direct the agricultural branches in the region into profitable channels by improving existing crops and developing new technologies and crops. Applying and transferring techniques developed by their R&D and other research institutes by means of model farms and an active extension service. Increasing efficiency in use of fresh and treated water; and improving the general professional level of local farmers. In the Arava Valley, for example, studies are conducted on new varieties of melons, tomatoes, peppers, fresh herbs, strawberries, dates, flowers, flower-seed production and harvesting, aquaculture, livestock, fodder crops, and jojoba beans, a year-round cash crop used in the production of cosmetics and lubricants.

MAJOR ACHIEVEMENTS

During the last 50 years the ARO and its forerunners – the Agricultural Research Station – were instrumental in changing the Israeli agricultural from a “mixed farming” system to a highly industrialized type geared to a large extent to export its produce to Europe. Production of avocado, new types of citrus, mango, grapes, sweet peppers, fresh herbs, tomatoes and a variety of ornamentals changed farming to a “high tech” operation. Many of the various steps are computerized and electronically controlled, enabling less than 2% of the population to produce all major horticultural products, and in addition to export agricultural products for about \$1.5 billion per year.

The severe limitations in the supply of high quality water necessitated a shift to the use of low quality and recycled water. At present about 44% of the water used for agriculture comes from recycled and low quality water, with the aim to increase their use up to 50%. This was achieved without lowering quality of the produce.

A substantial part of the agricultural products are exported, mainly to Europe. Exports include fruits (citrus, avocado, grapes), vegetables (sweet peppers, tomatoes, potato, melons, sweet potato), ornamentals (cut flowers, potted plants, propagation material) and herbs. Agricultural export (fresh and processed) for

1997 reached over \$1.329 billion – approximately 6.4% of the country's total exports (source: Central Bureau of Statistics). This requires a permanent effort to innovate with new products, niches in seasons, better storage technologies to enable surface shipping and of course superior quality.

Major achievements included an increase in productivity of fruit, vegetable and field crops with a reduced input of chemical fertilizers and pesticides.

Efficiency in dairy farming increased markedly with milk production reaching highest level in the world of more than 11,000 litre/cow/year.

FUTURE OUTLOOK

Agricultural research in Israel will have to maintain its leading position to ensure food supply with minimal water use, exports of its present and future agricultural products, preserving the open spaces and developing new technologies for its own agriculture and for exports. All these will help to keep the present farming population on the land, with a decent standard of living.

REFERENCES

http://en.wikipedia.org/wiki/Mikveh_Israel_Settlement

Oren, A. 1993. Agricultural experiments and trials in the Jewish settlements from their beginning until the first world war. Yad ben Zvi and the Agricultural Research Organization (in Hebrew).

Turel, S. (ed.) 2006. *Chronicle of a Utopia: The Templers in the Holy Land, 1868–1948*. Eretz Israel Museum, Tel Aviv (in Hebrew and English).

CHAPTER 19

CONCLUDING REMARKS

GEORGE THOTTAPPILLY¹ AND GAD LOEBENSTEIN²

¹*Dean of Studies, Biotechnology, Sahrdaya College of Engineering and Technology, Kodakara P.O., Thrissur 680 684, Kerala, India;* ²*Professor Emeritus, Department of Virology, Agricultural Research Organization, Bet Dagan 50-250, Israel*

It is difficult to present concluding remarks regarding the chapters included in this book on Agricultural Research Management, as problems, agro-climatic conditions, marketing, farmer's knowledge and attitudes, and political systems vary from country to country. Nevertheless, we tried to point out some common traits and deficiencies in our present system.

The productivity gains from high-yielding varieties as well as judicious use of fertilizers and pesticides, allowed the world's farmers to double global food output during the last 50 years, on roughly the same area of land, at a time when global population rose more than 80%. Without these improvements in plant and animal genetics, improved production practices and other scientific developments, known as the Green Revolution, we would today be farming on every square inch of arable land to produce the same amount of food and to feed the increasing population. In Western countries this was associated with a marked decrease in the farming population, where often less than 3% of the population supplies the local market with food, and often leaves in addition a sizeable part for exports.

By adopting Green Revolution technologies, many countries in Latin America and Asia benefited. However, many people in sub-Saharan Africa and parts of South Asia continue to suffer from poverty driven by poor farm productivity. There are about 800 million people in the world, who go to bed daily on an empty stomach, and nearly 40,000 people – half of them children – die every day of starvation or malnutrition. Increasing populations and inadequate poverty intervention programmes have eaten up many of the gains of the Green Revolution. Most people around the world have access to a greater variety of nutritious and affordable foods than ever before, thanks mainly to developments in agricultural science and technology (Prakash and Conko, 2004). In almost every country, the average human lifespan – the important indicator of quality of life – has increased steadily in the last century. Even in many less-developed

countries, lifespans have doubled over the past few decades. Despite massive population growth, from 3 billion to more than 6 billion people since 1950, the global malnutrition rate decreased in that period from 38% to 18% (Prakash and Conko, 2004). India and China, two of the world's most populous and rapidly industrializing countries, have quadrupled their grain production. The Research Managers can definitely play a key role in increasing food production.

ORGANIZATIONS AND FUTURE OUTLOOK

Many agricultural research and extension organizations in developing countries need to be decentralized, more strongly farmer-oriented, and more closely linked within the technology-generation and dissemination process. The research managers may consider "farmer participatory research" for better interaction with farmers and adoption of new technologies. This will also lead to projects, which are important to the farmers rather than scientists' fascination for new knowledge, but no relevance to the farmers. The research managers should be aware of the new developments and ways must also be found to improve access to information by less-educated farmers – because of equity reasons and also to facilitate accelerated adoption of the newer knowledge-intensive technologies.

The world has the technology – either available or well-advanced in the research pipeline – to feed a population of 10 billion people. The Research Managers should make sure that farmers be permitted to use this new technology, and education and extension work be carried out. Improvements in crop management productivity can be made all along the line – in tillage, water use, fertilization, weed and pest control, and harvesting. In addition, for the genetic improvement of food crops to continue at a pace sufficient to meet the needs of the 8.3 billion people projected in 2025, both conventional breeding and biotechnology methodologies will be needed (Borlaug, 2001).

The record of agricultural progress during the last century speaks for itself. Countries that embraced superior agricultural technologies have brought unprecedented prosperity to their people, made food vastly more affordable and abundant, helped stabilize farm yields, and reduced the destruction of wild lands. Recently, however, there is a marked trend in universities and research institutes in Western countries to concentrate on basic biological research, while application in the field is left to extension workers and private companies. This is linked with a severe reduction of student enrolment in the classic agricultural sciences as agronomy, horticulture and soil science. It is expected that within a decade or two this shortage in agricultural experts will have repercussions on agricultural production, especially if new diseases or pests shall cause epidemics. Also, the new biological developments, especially in molecular biology and genomics will require agriculturalists to apply them to crops. Furthermore, this discontinuity will lead to a loss in knowledge, acquired during the last 50 years.

The research managers should be aware that in Western countries the private sector is doing more basic research now while in developing countries,

the universities and research institutes funded by governments are doing the basic research. Since governments cannot provide adequate funds for projects, research outcome in developing countries is also limited. Moreover, many scientists in the government system are not motivated. Often they accept these jobs for the sake of job security in the government system. Also, let alone the good scientists are not adequately rewarded, but many well-connected mediocre scientists get promoted to positions of authority due to the rampant politicization of many academic and research institutions in developing countries.

Agricultural researchers and farmers in Asia face the challenge during the next 25 years of developing and applying technology that can increase the cereal yields by 50–75%, and to do so in ways that are economically and environmentally sustainable. Much of the near-term yield gains will come from applying technology “already on the shelf”. But there will also be new research breakthroughs – especially in plant breeding to improve yield stability and, hopefully, maximum genetic yield potential – if science is permitted to work as it should be. Crop productivity depends on both the yield potential of the varieties and the crop management employed to enhance input and output efficiency. Crop management productivity gains can be made all along the line – in tillage, water use, fertilization, weed and pest control, and harvesting.

Higher incomes and urbanization are leading to major changes in dietary patterns. While per capita rice consumption is declining, wheat consumption is increasing in most Asian countries, an indication of rising incomes and westernization of diets (Pingali and Rosegrant, 1998). Per capita consumption of fish, poultry and meat products is on the rise, and this expanding poultry and livestock demand will, in turn, require growing quantities of high quality feeds to supply its needs (Rosegrant et. al., 1995).

LEADERSHIP

Leadership in agricultural research, as in other organizations, is a prerequisite for success. The heads of a university (Vice Chancellor, VC), institutes (Directors) or departments should be selected from well-established, eminent and capable scientists and technical cadre purely on the basis of impeccable academic standing, merit, integrity, character, determination, leadership qualities and accomplishments, without any political interference to implement far-reaching policies. In many Western countries some of the appointments are time limited, with a possibility to extend the term. A search committee often selects them, with participation of eminent scientists from outside institutions (and farmers). This enhances the influx of new ideas and prevents inbreeding. The senior staff should be represented in such a committee but should not form a majority in decision-making.

In some developing countries, the quality of research leaders and managers of many academic, research and development institutions has declined sharply over the years. This is partly because the search committees are not empowered

to conduct a talent search as political considerations outweigh merit, suitability and other qualifications. Also, the other staff members of the institution do not play any role in the selection; they are even not informed about the candidates. The VC and the Directors should be globally recognized experts in their respective fields to articulate and develop relevant and innovative research programmes that attract international collaboration and to bargain forcefully for external funds. In the Indian context, one requirement in the case of VC and Directors could be to identify candidates who are Fellows of Indian Science Academies and/or foreign academies. The minimum qualification should be a fellow of at least one academy. This will guarantee that the person has a certain degree of standing and respect among their peers and the scientific society. In India, often the trend is to appoint administrative civil servants as VC of an agricultural university or Director of an institute. When he is a civil servant, the technical capacity of the university is sacrificed. There are excellent scientists with outstanding scientific accomplishments and remarkable experience in administration, and the committee should be free to identify such talented persons.

In many institutions appointments for scientific leadership positions are often limited for a term of 4–5 years – with the possibility of an additional term. The director should be selected based on qualifications and at a prime age where he can serve the organization for several years. In some developing countries, however, people are often promoted just before retirement. Within a short time, the new Head will also retire and the next in line (seniority) will become the Head. This is not good for the institute. The person who is selected should be able to serve the institute for at least 5–10 years so that certain positive changes can be implemented.

BUDGETS

Once the budget is prepared and approved, the Head of a Department should have freedom (within limits and with the approval of the Institute's administration) to make budgetary changes. Additional outside approval should be required only in high-cost items. In some developing countries, the minister at the central government has to approve minor expenses, as foreign travel of scientists, including those of institute directors. This means an unnecessary delay in preparation and approval.

OPEN HOUSE

Publicly funded institutions should organize periodically an open house (every 1–3 years), so that the public (tax payers) can view and assess their work. This will be a major tool to improve the public relation of the institute, help in transferring their new results to the public and promote accountability and transparency of the research management.

ANNUAL RESEARCH REVIEW AND PLANNING MEETING

It is a good practice to review all institutional projects once a year in the presence of all scientists in the institute, so that the Director can assess whether the project is on the right path. It will also be a good learning experience for other staff members. One should review if the methodology used is appropriate or the project. It is important that all staff members are present in this review meeting and total involvement is required. Ultimately one can discuss the experiments planned for next year as well as budget, travel plans, future publications, land and labour requirement.

PROMOTIONS

Criteria for promotions are most important as they serve as a guideline for the researchers in which direction to lead their research. While in universities and some central research institutes in the Western world the emphasis will be on basic long-term research, in the developing countries promotions should not only be based on basic research, but also on applied and adaptive research directly related to the needs of the local agriculture. External evaluation by outside peers is a necessity, especially in small institutes in developing countries. It is advisable to have outside scientists on the promotion committees and request confidential evaluations from qualified scientists outside the candidate's institute or country. The letters of recommendation should include the sentence "that the candidate for promotion is of a similar scientific standing as the parallel rank in our university (or institute)". It is also advisable to appoint junior scientists, who graduated from a different university, and that to get new ideas and ways of operation. In many developing countries, students with all three degrees from one university will continue to work there and then get promoted to professors and/or even VCs and work there until retirement. This is a form of extreme inbreeding, which prevents new initiatives and innovation. Since sabbatical leave is not common, they have no other external experience or exposure. In the USA, a person with all three degrees from one university will probably not get a position in the same university. Promotions and annual increments should be based on number of well-defined criteria such as quality publications, citation index, patents, courses taught, effectiveness in teaching as assessed by students and number of postgraduate students under direct supervision. Additional criteria include development of new varieties/technologies, adoption of technologies by others, economic benefits of these new technologies and external funding obtained.

CITATION INDEX

In developing countries, there is a sad trend of publishing in any journal in order to increase the number of publications. The quality of publication is often sacrificed. The citation index counts – the number of times an article is cited

by others – is an indicator of research relevance, quality and impact. The number of publications alone will not be enough in deciding on researchers' annual increment and funding their research. Citation counts have to be considered in order to judge the quality of publications. It is good to introduce an institutional publication committee who will review manuscripts and then give institutional permission. This committee can advise that only quality manuscripts will be submitted to the journals.

PATENTS

Today patents are as important as publications, and research managers may encourage the staff members to apply for patents.

SABBATICAL LEAVE

Many developing countries have not introduced the system of sabbatical leave whereby the faculty members can go to another university or institute for additional and new experience. Scientists are supposed to upgrade themselves continuously and on-the-job training is very important. Those who have taken sabbatical leave can vouch for the benefits of sabbatical leave. The Research Managers may push for sabbatical leave system for their staff. The idea of Centres of Excellence is very valuable. However, it should not be based on financial compensation, but reflect the quality of personnel, access to facilities and freedom of choice in research.

APPLICATION OF MODERN TECHNOLOGIES

In making a decision on research portfolios, the research managers should recognize that in majority of developing countries, there is a vast potential for improving productivity of agriculture through application of modern technologies. In addition, there is a tremendous scope for post-harvest processing and agro-based industries for value-addition and vast opportunities for export of quality farm products. Research management should consider agriculture as an efficient, eco-friendly production system, which has to become a major power for a comprehensive socio-economic transformation of the country. This is an exciting opportunity and a challenging responsibility. The research management should aim to achieve food and nutritional security, alleviation of poverty and unemployment, natural resource management in a global atmosphere. For many developing countries, sound agricultural development is important for economic growth. In Western countries, research management, in spite of severe cuts in government funding, seems to concentrate on long-term research, but it is still advisable to keep the traditional agronomic research. This is especially important, as the new technologies, evolving from basic molecular and cellular research, have to be integrated into the plant (and animal) systems. It is also a necessity that Western researchers (and funding) will

have to be more involved in the problems of the developing countries. The foreseen population explosion, especially in developing countries, requires a parallel increase in food production; otherwise severe political repercussions will result.

PUBLIC–PRIVATE PARTNERSHIP

This is an area where research managers should pay more attention. A good institute should develop a good public–private partnership with a win-win proposition for both parties. Even graduate students should undergo practical apprenticeship training in relevant industries to enhance their skills, application of their knowledge in the real-world situation and employability after graduation. A good public–private partnership will increase the relevance of publicly funded research and will promote development of technologies that can be commercialized by the private sector. The private company must fund some of the research if the research outputs are expected to be of benefit to it. The public–private partnership will increase the focus of research on practical, locally important, real-world problems that when solved will enhance the profit of private enterprises and improve the prestige of public institutions. The profit can be even shared between the public and private organizations and the scientists who solved the problem and developed the products should be rewarded adequately.

LIBRARIES

Most of the 2.5 million articles published yearly in over 20,000 journals are inaccessible to a large portion of their potential users worldwide, but especially to those in the developing world. No research institution can afford to subscribe to all journals. The only way to make all those articles accessible to all their potential users is to provide open access to them on the Web. This should be an area where international institutions (as UNDP, FAO, CGIAR, World Bank, FAO, UNDP, CGIAR, etc.) and donors should be involved to make the required financial contributions. Research managers have to allocate a certain percentage of their budgets to buying books and subscribe to e-journals.

COMPUTER LITERACY

Unfortunately many senior research managers, especially in the developing world, are not computer literate. Without knowing the potential of computers, they are unable to apply or promote the application of computers in research. Also, office management and accounting can be made more efficient and friendly by using modern ICT technologies (see chapter 8). It would be possible to reduce office staff thereby making savings, which could be used to hire scientists or technicians.

FUNDING

At present, funding of agricultural research in both Western and developing countries is decreasing. This is especially difficult for research institutions in developing countries, in view of the shortage of food and their general economic situation, and dependency to a large extent on agriculture for their livelihood. Cuts in funding CGIAR are severe and do not enable them to fulfil their obligations, even though some of their institutes require organizational and professional upgrading and changes. The European Union should take a greater part in promoting agricultural research for the benefit of developing countries. Scientists should be encouraged to seek external funding, and additional matching funds from the institute should reward those who get external funding. The Research Managers should arrange for young scientists short courses on how to write and present good grant proposals to donor agencies.

EDUCATION AND CURRICULUM CHANGES

As mentioned above the decline in Western countries in students enrolment in the agronomic sciences and the subsequent cut in positions in these departments, will in the long term have marked repercussions on agricultural research, development and practice. In many developing countries there is a continual deterioration in the standards and quality of science education. The curriculum should be appropriate for the present period of a changing world. In many developing countries, the structures of governance are not conducive to change, particularly curriculum change. Curricula and courses have not changed for decades.

The recent trends of bright boys and girls shying away from agricultural science education have compounded the already grave situation still further. These young boys and girls, particularly the brighter ones, feel that agricultural science is not exciting and challenging enough to make it their life's mission.

SUSTAINABLE AGRICULTURE

Sustainable agriculture integrates three main goals: environmental health, economic profitability, and social equity. Sustainability rests on the principle that we must meet the needs of the present without compromising the ability of future generations to meet their own needs. Therefore, stewardship of both natural and human resources is of prime importance. Stewardship of human resources includes consideration of social responsibilities such as working and living conditions of labourers, the needs of rural communities, and consumer health and safety both in the present and the future.

It is important for the research managers to recognize that a country's economic and social well-being no longer depends on "manpower, capital and land", but instead relies on "know-how, new technologies, information and dissemination".

It is important to percolate the latest developments to the farm community. Such trends present special challenges for developing countries because they often must give priority to basic human needs in the short term, while trying to keep pace with rapid scientific and technological advances over the long term. Nevertheless, the current trends strongly suggest that all countries must devise strategies to “develop advanced technologies” as fast as possible, which have become the foundation of the new global economy. Developing countries must not only invest in national programmes for basic and applied research, but must encourage international scientific cooperation to foster the competence and quality that are essential to compete successfully at international markets. In addition, such co-operation will facilitate “technology transfers” that could greatly accelerate future progress in science-based development throughout the developing world. To mitigate these problems, the developing nations should strengthen the basic infrastructure and capabilities of their institutes, develop effective policies and adoption of strategies, and become more proactive. Instead of importing technologies from abroad, the research managers should also aim at developing these technologies locally. No Research Manager can thrive in total isolation.

Europe and later the USA, where the industrial revolution began in the 18th century, became the centres of science and technology. Compared with developing countries there is a global imbalance in scientific and technological know-how, which developed over the last three centuries that created even more serious imbalances in economic and social well-being. Only 4% of the new science is currently produced by the developing world, despite the fact that 80% of the world’s population – more than 4 billion people – live there.

INTERVIEWS AND SELECTION OF CANDIDATES

In many developing countries, the interviews for scientific positions are very formal, but without spending much time with the candidate. The certificates are scrutinized thoroughly and the candidates appear before a panel for interview. The questions may range from defining the subject just like in undergraduate courses. Those who do well in this short interview will be selected. On the other hand, in many developed countries and CGIAR centres, the interview lasts for 2–3 days. The candidate will meet all categories of faculty and conduct discussions. The candidate is free to ask questions and clarify doubts about the position, responsibilities and the institute. This administration believes that the institute is hiring him/her until his/her retirement and will spend at least a few million dollars for their salary and research. So both the candidate and the institute should be fully aware of the strengths and weaknesses of the candidate. His temperament, knowledge in the subject, aspirations and willingness to work diligently will be known by the end of 3 days. Only two or three selected candidates are invited for the interview, while in some developing countries almost everyone who had applied for the post will be invited. In this process the interview is very superficial,

while in the international centres and advanced countries, the interview is very thorough. It is the potential of the candidate for the next 20–35 years that they really check; in developing countries, the immediate knowledge has more stress. In many countries, the candidates for tenure-track positions will have to give an open seminar to the entire staff of the institute. Many staff will be asked to evaluate the candidate and write confidential reports.

COMPETITIVE SALARY

Many institutes and universities in Western countries can offer appropriate salary to attract the best candidates. Such a system exists in developing countries only in the private sector. Most institutes in developing countries do not have the freedom to offer a higher salary. This limits in selecting good candidates.

SENIORITY VS MERIT

In many systems, seniority is more important than merit and outstanding performance. This has negative impact on individual performance and the institutional service and delivery to the public. People know that superior performance and hard work may not be rewarded, which is true in many developing countries. This often causes young scientists and other staff to lose interest in their work and spend their time on activities that will benefit them and not the institution.

BUDGET CUTS AND REDUCTION OF STAFF

In many international centres about 50–60% of total budget is set aside for staff salary. If there is a shortfall in funding, staff will be reduced accordingly to keep this ratio. In this way the remaining staff will have a reasonably good working capital. On the other hand, in many developing countries, the proportion of budget for staff salary keeps increasing year after year due to reduced funding. Occasionally the staff salary accounts for 80–95% of the total budget leaving no funds for research.

Permanent staff vs temporary staff: For most jobs, the staff are recruited on a probation, which may vary from 6 to 12 months. Once the probation is over, the staff will be hired as permanent. Generally there is a big change and negative attitude towards work, punctuality, motivation, etc. once a person is made permanent. This may be true for some Indian conditions but even not for all developing countries.

FARMERS' INCOME

It is a reality that in general farmers' income has dropped ever since yields of crops have gone up. The net beneficiaries of the green revolution are not farmers, but urban people, because the prices of farm products came down

when yields and production went up. There is an urgent need to formulate policies how to increase farm income while increasing agricultural production. This is a challenge the research managers may face in the coming years. We talk only of increasing production, but we forget the poor farmers in this process. Since farming is not a lucrative profession any more, many farmers are selling their land and moving to urban areas.

CONCLUSION

Research Managers, especially in developing countries, may look into some of the above points in managing their institution so that more efficiency and transparency can be introduced. This should lead to motivate the staff to perform better and deliver better results for the benefit of farmers. It is our belief that there is room for improvement in the present management style especially in some developing countries.

ACKNOWLEDGEMENTS

We thank Drs V. Balasubramanian and D.V.R. Reddy for their valuable suggestions in preparing the manuscript

REFERENCES

- Borlaug, N.E. 2001. Feeding the world in the 21st century: the role of agricultural science and technology. *AgBioWorld*, April 2001.
- Borlaug, N.E., and Dowswell, C. 2000. Agriculture in the 21st century: vision for research and development. *AgBioWorld*, March 2000.
- Pingali, P.L., and Rosegrant, M.W. 1998. Supplying wheat for Asia's increasingly westernized diets. *American Journal of Agricultural Economy* 80(5), Proceedings Issue, 954–959.
- Prakash, C.S., and Conko, G. 2004. Technology that will save billions from starvation. *AgBioWorld*, March 2004.
- Rosegrant, M.W., Agcaoili-Sombilla, M., and Perez, N.D. 1995. *Global Food Projections to 2020*. IFPRI, Washington, DC.

INDEX

A

- AARIRENA, 68
- Accountability, 34, 38, 47, 59, 65, 81, 111, 123, 145, 224–227, 280, 282, 312, 324, 370
- Accreditation board, 309
- Achievements, 96, 100, 161, 224, 268, 269, 364, 365
- Adherence to ethical norms, 123
- Administration, 6, 14, 24, 72, 95, 96, 98–101, 104, 117, 218, 224, 234, 239–241, 248, 257, 266, 281, 302, 306, 313, 314
- AES scope, 235
- Agenda setting process, 80, 81
- Agribusiness, 4, 154, 244–246, 252, 353
- Agricultural biotechnology, 122, 127
- Agricultural development Projects (ADPs), 188, 273, 276
- Agricultural Experiment Station (AESs), 3, 231–242, 244, 260, 264, 265, 357, 358
- Agricultural genomics, 261, 262
- Agricultural Gross Domestic Product (AGGDP), 319, 320
- Agricultural industrialization, 235–237
- Agricultural research centers, 38, 40, 76, 192
- Agricultural Research Council of Nigeria (ARCN), 272, 277, 279
- Agricultural Research Organization (ARO), 38, 159, 173, 188, 191, 192, 254, 358–364
- Agricultural Research Service (ARS), 214–229, 238, 260, 311, 322, 323, 326, 328, 348, 362
- Agricultural research, 3–6, 9, 12–14, 16, 18–25, 31, 32, 37–39
- Agricultural revolution, 9
- Agricultural Scientists' Recruitment Board (ASRB), 322, 323, 326
- Agri-food valley, 351, 352
- Agrobacterium, 128
- Agroecoregional zones, 39, 68, 82, 242, 253, 254
- All India Coordinated Research Projects (AICRP), 308, 309, 313, 314, 317, 323–325, 328
- Alliance of future harvest centers, 195
- Allocation of research resources, 39
- Animal biotechnology, 127–129
- Animal care, 124, 134, 241
- Animal health service, 342
- Animal health, 271
- Animal husbandry, 93, 236, 285, 305, 306, 332, 335, 338, 347
- Annual Assessment Report (AAR), 322
- Annual General Meeting (AGM), 193, 194
- Annual project reports, 223, 226
- APAARI, 68
- Applied and adaptive research, 57, 65, 66, 371
- Arava Regional Research Program, 164
- Area director, 215, 224
- ARS national programs, 216–218
- ARS mission, 214
- ARS online, 213
- ASARECA, 68, 69
- Assessing performance, 223
- Autocratic (authoritative), 76, 105, 106, 108
- Autonomy, 122, 282, 323, 328

B

- Ballistic impregnation, 128
- Bard, 362
- Beltsville, 215
- Benevolence, 122
- Benin, 207, 272
- Bioethics, 121–145
- Bioinformatics, 6, 85, 150, 154, 155, 222, 265
- Biological boundaries, 129
- Biological control, 80, 207, 208, 343, 345, 346, 363
- Biosafety, 5, 87, 195, 241
- Biotechnology, 5, 18–20, 28, 44, 68, 69, 85, 86, 90, 122, 127–130, 132, 325, 350, 368
- Biothics,
- “Blue sky” (basic) research, 66
- Board of trustees, 86, 189, 192, 195–197, 210
- Bogor, 191
- Borlaug, 188
- Botanical research station, 271
- Brain-storming, 100
- Breeding in potatoes, 343
- British empire, 10
- Brundtland commission, 21, 22
- Budgets, 24, 25, 47, 66, 69, 72, 97, 98, 100, 151, 200, 223, 224, 238, 241, 277, 361, 362, 370, 373
- Bulb research, 334, 346

- C**
- Career advancement system, 326
- Carefulness, 124
- Center director, 192, 193, 202
- Center Directors’ Committee (CDC), 195
- Central Institute of Fisheries Education, 315
- Central Tobacco Research Institute, 306
- Centro Internacional de Agricultura Tropical (CIAT), 17, 21, 189–191
- CGIAR chair, 192, 193
- CGIAR charter, 192
- CGIAR co-sponsors group, 193
- CGIAR secretariat, 17, 83, 192, 194, 195, 198, 210
- Challenge program, 25, 29, 32, 116, 193, 195, 198, 201, 325
- Chief scientist, 151, 158–164, 166, 361
- Choice of research topics, 127–129
- Center for International Forestry Research (CIFOR), 191
- CIMMYT, 5, 17, 83–86, 189–191, 309
- Civil society, 65, 68, 70, 73, 77, 192
- Client-driven agenda setting, 75–77
- Coconut research stations, 306
- Code of practice, 133, 134
- Colombia, 13, 14, 17, 26, 27, 189, 191
- Colonial times, 10, 11, 13
- Communes, 14
- Communication, 39, 94, 95, 98, 110, 111, 114, 115, 117, 124, 144, 181, 192, 218, 239, 244, 256, 257, 264, 266, 275
- Communism, 138
- Comparative advantages, 26, 32, 68, 69, 78, 160
- Competence, 124, 131, 140, 154, 155, 196, 277, 289, 290, 294, 300, 354, 375
- Competitive grants program, 259–261
- Confidentiality, 86, 126, 134, 153, 267, 322
- Connecticut, 233
- Consensual (delegable), 105, 106
- Consultation, 43, 68, 70, 76, 84, 85, 90, 99, 105, 106, 108, 109, 114, 197, 227, 300
- Consultative (collaborative), 16, 33, 65, 76, 82, 105, 106, 116, 123, 141, 143, 149, 222, 287, 298–300
- Consultative Group on International Agricultural Research (CGIAR), 5, 17, 25, 40, 59–61, 67, 76–78, 81–83, 119, 187–211, 273, 298
- Contract research, 87, 178, 180, 244, 348, 349, 354
- Cooperative agreements, 220
- Cooperative extension service, 231, 244, 245, 248, 252
- Cooperative State Research, Education and Extension Service (CSREES), 214, 238, 239, 240, 259, 264–268
- CORAF/WECARD, 68, 280
- Core budget, 21, 25, 98
- Cost-benefit analysis, 48–50, 52, 53

- Cotton Technology Research
Laboratory, 306
- Crop production and protection, 216
- Cytoplasmic Male Sterility (CMS), 309
- D**
- Dairy products, 336, 345
- Data analysis, 124, 138–140, 287
- Data collection, 138, 139
- Decision support system, 38, 39, 163
- Deontology, 125
- Department for Agricultural Research
and Education (DARE), 323,
326, 328
- Department of Science and
Technology, 321
- Developing nations, 9, 16, 20, 22, 28, 31,
34, 35, 375
- Director, 71, 164, 192, 193, 239, 240, 273,
291, 312, 314, 334, 342, 359–361,
370, 371
- Director General, 21, 35, 192, 195–198,
210, 277, 293, 309, 323, 326, 328
- Disciplines, 19, 32, 39, 84, 99, 103, 108,
123, 141, 142, 151, 169, 181, 204,
236, 251, 255, 269, 288, 291, 294,
296, 297, 314, 315, 318, 339, 358,
359, 363
- Disinterestedness, 138
- Dissemination and feedback, 149, 150
- Diversity, 47, 60, 75, 88, 89, 104, 110, 116,
155, 206, 225, 237, 251, 267, 289,
291, 293, 315
- E**
- Ecological zones, 201
- Economic indicators, 53, 155–157
- Economic models, 38, 49
- Economic surplus, 48, 50–54, 56
- Ecoregional programs, 84, 193, 195, 201
- EER triptych, 331, 333, 341–343
- Effective leadership, 102, 110, 111, 119, 120
- Encomienda system, 11
- Environment, 3–6, 21–23, 29, 31–34, 39,
40, 42, 43, 46
- Equity effects, 45
- Ethical approval, 136
- Ethical obligations of authors, 141–143
- Ethics, 121–123, 125, 130, 131, 141–143,
145, 195
- EU framework programs, 297, 298
- European Forum on Agricultural
Research for Development
(EFARD), 68
- Ex situ, 205
- Executive council, 192–194, 361
- Expected welfare gains, 41
- Expert function, 300, 301
- Extension system, 41, 200, 201, 316
- Extension systems (human resources), 41,
52, 72, 118, 119, 201, 244, 274, 296,
297, 316, 325, 374
- External reviews, 81, 279–282
- Extra-ordinary budget
- F**
- Faculty of agriculture, 358, 363, 364
- Famine commissions, 305
- FARA, 68, 69, 280
- Farmer organizations, 72–74, 165
- Federal Agricultural Co-ordinating Unit
(FACU), 276
- Federal Department of Agricultural
Research, 271, 272
- Federal Ministry of Agriculture and
Rural Development, 273
- Federal Ministry of Science and
Technology (FMST), 273
- Feedback process, 54
- Fertility restorer systems, 309
- Fisheries, 5, 15, 199, 271, 273, 280, 318
- Food and Agriculture Organization of the
United Nations (FAO), 15, 16, 187,
190–194, 280, 298, 373
- Food security, 5, 17, 26, 28, 29, 43, 45, 75,
79, 80, 86, 282, 318
- FORAGRO, 68
- Ford foundation, 15, 17, 188, 190, 191, 309
- France, 11, 13, 190, 191, 286, 287, 290,
296, 302, 303
- Free trade agreements, 26–28
- Freedom from hunger, 187
- French research system, 286
- Funding, 17, 21, 22, 34, 35, 39, 40, 61, 66,
68, 72–74, 81, 82, 86
- Future harvest centers,

G

Gates foundation, 32, 33, 198
 Genanimal, 292
 Genebank, 199, 203–206
 General Agreement on Tariffs and Trade (GATT), 25
 Generic recommendations, 280
 Genetic engineering, 122, 123, 125, 127, 129, 203
 Genetic modification, 127–129, 135, 136
 Genetically Modified (GM) crops, 33, 114, 129, 130, 135, 136, 151
 Genetically modified and cloned animals, 135, 136
 Genetically Modified Organisms (GMOs), 18, 19, 122, 127, 128
 Geo-political regions, 271
 German templers, 357
 Germplasm, 18, 19, 21, 23, 34, 56, 83, 86–88, 90, 137, 198, 199, 203–207, 216, 256, 309, 315
 Global Forum for Agricultural Research (GFAR), 67, 68, 193, 194
 Ghana, 201, 208, 272, 280
 Glasshouse industry, 346
 Global forum, 67, 68, 114
 Government policies, 43, 44, 61, 285
 Grains Research & Development Corporation (GRDC), 74
 Grants, 74, 82, 94, 97, 202, 215, 234, 237, 242, 243, 245, 248–252, 260, 263–265, 311, 317, 321, 337, 360, 362, 363
 Green revolution, 16, 17, 21, 74, 189, 367, 376
 Gross Domestic Product (GDP), 27
 Growth linkages, 47

H

Harvest plus (bio-fortification), 32
 Hatch act, 233, 234, 242, 244, 252
 Head of the institute, 99, 100, 359
 Hebrew University in Jerusalem, 358
 Historical background, 187–192
 History of AESs, 232–237
 Home economics, 234, 244, 246
 Horticulture, 5, 98, 219, 332, 334, 335, 337, 338, 368

Human resources, 52, 72, 118, 119, 227, 244, 274, 293, 296, 297, 303, 374
 Human response, 99

I

Ibadan, 17, 189, 191, 271, 272, 275
 Impact assessment, 54, 55, 58, 70, 194
 Imperial Bacteriological Laboratory, 305
 Imperial Council of Agricultural Research (ICAR), 305–328
 Implementation team, 78
 Inclusiveness, 60, 67, 122
 India, 5, 11, 14, 16, 17, 20, 73, 90, 188, 191, 299, 306–308, 311, 316, 318–320, 323, 324, 326–328, 368, 370
 Indian Agricultural Research Institute (IARI), 305, 315, 327
 Indian Institute of Sugarcane Research, 306
 Indian Planning Commission, 309
 Indian Veterinary Research Institute (IVRI), 305, 315
 Indirect costs, 242
 Indonesia, 11, 191, 321, 339
 Industrial revolution, 16, 375
 Informal leaders, 105, 109, 110
 Information and Communication Technologies (ICT), 149–167
 Information and knowledge, 149, 150, 164, 220
 Information department, 201
 Innovative approach, 87, 117, 269
 INRA, 4, 285–303
 INRA'S scientific organization, 290–293
 INRA'S missions, 285–288
 Institute level (minigovernance), 277
 Institute of Agricultural Research (IAR), 278, 281
 Institutional organization, 314–316
 Institutionalization, 38, 58, 62
 Integrity of science and scientists, 130, 131
 Integrity, 104, 122, 124–126, 130, 131, 138–140, 143, 152, 206, 267, 369
 Intellectual property (IP), 86, 124, 136, 243, 256
 Intensive Agricultural Development Program (IADP), 309
 Inter Territorial (West African) Research Institutes, 271, 272

- Inter-American Institute of Agricultural Sciences (IICA), 14
- Intermediate products, 69, 174, 179, 180, 236
- International bank for reconstruction and development (IBRD), 187
- International cooperation, 97, 166, 285, 288, 295, 297, 299
- International Crops Research Institute For the Semi- Arid Tropics (ICRISAT), 5, 59, 60, 87, 90, 191, 196, 273
- International Food Policy Research Institute (IFPRI), 35, 191
- International Fund for Agricultural Development (IFAD), 188, 191–193, 207
- International Institute of Tropical Agriculture (IITA), 5, 17, 78–81, 189, 192, 196, 198, 199, 201, 206–208, 273
- International Livestock Research Institute (ILRI), 191, 337
- International Monetary Fund (IMF), 20, 31
- International Network for the Improvement of Banana and Plantain, Montpellier (INIBAP), 191
- International Plant Genetic Resources (IPGRI), 191, 204–206
- International Potato Center (CIP), 17, 189–191
- International Rice Genome Sequencing Project, 203, 204
- International rice research institute (IRRI), 17, 188, 190, 191, 203, 204, 309
- International Service for National Agricultural Research (ISNAR), 191, 280
- International Water Management Institute (IWMI), 191
- Internet, 15, 150, 162, 164, 165, 222, 223, 225
- IPO, 336, 345, 346
- IR8, 188
- Israel, 151, 154–162, 164, 166, 172, 357–365
- Italy, 191
- Ivory coast, 191
- J**
- Jewish agency, 357, 358, 364
- Jute Agricultural Research Laboratory, 306
- K**
- Kaduna, 272
- Kellogg foundation, 15, 337
- Kenya, 5, 11, 191
- King Baudouin award, 197
- Knowledge Base Management System (KBS), 163
- Krishi Vigyan Kendras (KVKs), 316, 317, 325
- L**
- Lac research institute, 306
- Land grant colleges, 13, 238, 358
- Landwirtschaftliche Versuchsstation, Moeckern, 232, 233
- Latifundismo, 11
- Latin america, 9–15, 17, 18, 28, 30, 72, 82, 85, 189, 207, 367
- Leadership, 35, 72, 73, 78, 95, 96, 98, 101–120, 177, 180, 181, 200, 213, 265, 292, 328, 359, 360, 363, 369, 370
- Leadership styles, 105, 106
- Learning cycles, 37–62
- Legality, 124
- Leventis foundation, 201
- Livestock, 4, 5, 127, 189, 196, 198–200, 216, 243, 269, 273, 275, 280, 282, 315, 318, 364, 369
- M**
- Maccarese, 191, 205
- Maize genome database, 222
- Maize, 5, 9, 10, 17, 18, 28, 29, 33, 81, 84, 85, 89, 188, 196, 204, 309
- Makerere university, 14
- Malaysia, 11, 14, 191, 321
- Management board, 291–294, 296, 297, 300
- Management Committee (MC), 311
- Management Information Systems, 156
- Management problems, 169, 170, 241
- Management Systems of Research, 199–202

- Management, 5, 21, 22, 25, 33, 34, 37, 40, 42, 43, 54, 55, 57, 58, 68
- Marker assisted selection, 6, 19
- Mashelkar committee, 314, 321, 322, 324
- Matrix managerial model, 293–295
- Mayer, 333
- Medium Term Plans (MTPs), 59, 195
- Millennium Development Goals (MDG), 82, 114–116
- Ministerial level (macrogovernance), 277
- Miqve Israel, 357
- Mission-oriented research, 76, 249, 289, 293
- MNCs, 87, 88
- Montague Chelmsford Reform, 305
- Moor plantation, 271, 272
- Moral values, 122
- Morality, 123, 125
- Morrill Act, 234
- Morrow plots, 233
- Multi-institution challenge programs, 201
- Mushroom, 157, 332, 334, 343, 345
- N**
- Nairobi, 14, 191
- NASULGC, 238, 239
- National Academy of Agricultural Research Management (NAARM), 323
- National Advisory Committee for Agricultural Research (NACAR), 273, 274, 277
- National Agricultural Research Project (NARP), 273–275, 277, 279, 280
- National Agricultural Research System (NARS), 39, 40, 59, 61, 72, 73, 76, 79–81, 88, 273, 274, 307, 310, 311, 314, 317, 319, 325, 326
- National Agricultural School of Chapingo, Mexico, 13
- National and University Institute of Agriculture, 358
- National Council for Science and Technology (NCST), 272, 277
- National Dairy Research Institute, 305, 315
- National Innovation Technology Program (NAIPs), 308, 311
- National program staff, 215
- National Research Centres (NRCs), 298, 315, 326
- National Research Initiative, 259–269
- National Research Initiative Clusters, 262
- National Research Institutes, 209, 272, 282
- National Science and Technology Development Agency (NSTDA), 273
- National systems, 72, 73, 153
- Natural Resource Management Projects (NRMP), 22
- Natural resources, 4, 5, 10, 26, 68, 75, 82, 83, 85, 154, 195, 199, 200, 208, 216, 259, 287, 289
- NERICA, 204
- Netherlands, 161, 190, 331–354
- Networking, 71, 153, 268
- New Partnership for African Development (NEPAD), 69
- New product development, 66
- New product strategy, 176
- Nigeria, 17, 73, 189, 191, 206–208, 271–283
- Non-discrimination, 124
- Non-Governmental Organizations (NGOs), 24, 65, 67, 68, 70, 72, 75, 78, 79, 265, 316, 341
- Non-maleficence, 122
- Northern Nigeria Department of Agriculture, 271
- Norwegian Government, 205
- NRI accomplishments, 268
- Nutrition, food safety/quality, 216
- O**
- Office of scientific quality review, 220–222
- On-Farm Adaptive Research (OFAR), 274, 276, 277
- On-station research (OSR), 276, 277
- Organisation for Applied Research, the Netherlands (TNO), 336
- Organised skepticism, 138
- P**
- Participatory research, 29, 72, 75, 324, 349, 368
- Partnerships committees, 76
- Pearson commission, 189

- Peer review, 124, 138, 143, 144, 220–222, 259, 260, 266–268, 275, 340
- Performance assessment, 321–325
- Personal scientific performance, 227, 228
- Personnel policy, 322, 323, 325–327
- Peru, 13, 15, 189, 191
- Plagiarism, 126, 142, 143
- Planning and execution of projects, 134, 135
- Planning horizon, 50, 176, 182
- Portuguese, 11
- Post-award management, 260, 268, 269
- Poverty considerations, 46, 47
- Pre-hispanic cultures, 10
- Principle investigator (PI), 130, 131
- Priorities, 30, 32, 34, 37–43, 45–62
- Priority setting, 38–40, 42–62
- Priority-setting requirements, 38
- Private sector, 15, 24, 32, 65, 66, 68, 69, 71–73, 76, 78
- “Problem-solving” research, 72
- Productivity constraints, 39
- Project design and data management, 138, 139
- Project leadership, 111
- Promotions, 99, 277, 297, 360, 371
- Prosperity, 17, 60, 260, 262, 307, 368
- Protectionism, 26, 27
- Public concern groups, 65
- Public sector funding, 151, 154
- Public-private partnerships, 87, 325
- Q**
- Qualitative impacts, 53, 54, 61
- Quinquennial assessment, 322
- R**
- R & D tactics, 174–177, 180
- Recombinant DNA techniques, 122
- Regional committees, 309
- Regional research centers, 364
- Relative strength of research (capacity building), 41
- Replacement, 23, 47, 128, 133, 137
- Research administration and management, 313, 314
- Research Advisory Committee (RAC), 311–313, 322–324
- Research agenda, 22, 24, 37, 38, 39, 47, 59, 66, 72, 75, 78, 81, 83, 84, 89, 90, 191, 193, 353
- Research and Development (R&D), 9, 18–20, 55, 66, 81, 97, 169, 189, 197, 219, 226, 227, 235, 253, 306
- Research department, 93–99, 294
- Research evaluation, 38, 40, 45, 47, 52, 53, 58, 60
- Research-extension-farm, 200
- Research institute, 39, 66, 68, 72, 73, 76, 94, 97–99, 117, 131, 141
- Research misconduct, 126, 127, 130
- Research options, 38, 43, 45, 48, 49, 53, 55, 69
- Research plan formulation, 274
- Research priorities, 30, 32, 37–62, 67, 158, 159, 214, 218, 219, 307–312, 360
- Research priority setting, 39–62
- Research problems, 39, 324
- Research process, 40, 56, 57, 60, 125, 126, 130–145, 228, 243
- Research programming, 274, 275
- Research results communication, 275
- Research staff, 94, 95, 200, 209, 274, 275, 360
- Research/extension linkages, 275–277
- Research-extension-farm, 200, 277
- Reservoirs of genetic variability, 206
- Resguardos’ or ‘encomiendas’, 12
- Respect for colleagues, 124
- Respect for intellectual property, 124
- Responsible mentoring, 124
- Review boards, 100
- Review process, 77, 143, 151, 229, 267
- Reviewers, 143, 266, 267, 361, 362
- Rice research station, 306
- Rights ethics, 125
- Rockefeller foundation, 15, 16, 33, 73, 188, 190
- Rokupr, 272
- Rome, 191, 194, 204, 207
- Royal Commission on Agriculture (RCA), 305, 306
- Rural infrastructure, 41
- Rural prosperity, 262, 263

S

SADC-FANR, 68
 SAES funding, 243
 SAES organization, 238
 Samaru, 271, 272
 Science council, 18, 76, 77, 80, 82–84,
 192, 194, 195, 197, 210
 Science of survival, 121
 Scientific fraud, 126
 Scientific manpower, 325–327
 Second generation of (national) research
 institutes, 271
 Seed sector, 88–90
 Seeds of innovation, 84–86
 Seminars, 94, 95, 99, 176, 202, 312, 359, 361
 Shared vision, 87, 108, 114, 119
 Sierra Leone, 272
 Small-Medium Enterprises (SMEs), 79,
 88, 89
 Social responsibility, 123, 124
 Socialist capitalism, 14
 Southern Nigeria Department of
 Agriculture, 271
 Spillover effects, 42, 58, 59
 Sri Lanka, 191
 Staff meeting, 95
 Staff promotions, 99
 Staff Research Council (SRC), 311–313,
 322–324
 Stakeholders, 39, 54, 60, 61, 65–70, 72–74,
 76, 81, 83, 86, 89, 117, 214, 217–219,
 221, 224, 229, 265, 266, 273, 341,
 349, 353
 Standing finance committee, 309
 State Agricultural Experiment Station
 System, 231–234, 243
 State Agricultural Universities (SAUs),
 310, 311, 314, 316–321, 324–327
 Strategic (mission-oriented) research, 76
 Strategic plan, 59, 61, 76, 170, 179, 182,
 217, 224–227, 266, 291, 350
 Strategic research, 4, 56, 73, 314, 315,
 324, 331, 334, 336, 344, 347, 349, 354
 Structured database, 58
 Sub-Saharan African countries, 274
 Sugarcane breeding institute, 306
 Supply and demand of commodities, 44
 System office unit, 192

T

Tafo, 272
 Target model, 79, 80
 Targeted objectives, 41
 Task group, 324, 325
 Teaching, 13–15, 94, 98, 121, 133, 134,
 155, 182, 235, 239, 240, 264, 317,
 325, 337, 342, 371
 Technical Advisory Committee (TAC),
 17, 18, 30, 194, 210, 362
 Technicians, 15, 94, 95, 164, 215, 241,
 250, 296, 303, 359, 373
 Technology, 5, 15, 18, 19, 26, 30–32, 34,
 38, 40–42, 47, 49, 50, 54–57, 60
 Technology Review Meetings
 (MTRMs), 277
 Tissue culture, 18, 93, 128, 205, 236
 Traditional tools, 48, 49
 Transfer to production, 176
 Typology, 47, 170, 173, 182

U

U. S. Land-grant universities, 231–257
 Umudike, 271, 272
 UNDP, 16, 17, 22, 187, 190–193, 373
 United States Department of Agriculture
 (USDA), 14, 213, 214, 217, 224, 229,
 238, 240, 242, 244, 259, 260, 265,
 285, 307, 323
 Universalism, 138
 University Grant Commission (UGC),
 307, 316, 317, 328
 University of Mexico, 188
 University of Viçosa in Brazil, 13
 US public law 308, 480
 USA, 190, 191, 308, 309, 319, 333, 361,
 362, 371, 375
 USAID, 15, 17, 317
 USDA mission, 213, 214
 USDA-CSREES, 259–269
 Utilitarianism (Teleology,
 Consequentialism), 125

V

Veterinary medicine, 244, 246
 Virtue ethics, 125
 Vision, 76, 83, 84, 85, 87, 96, 101–104,
 106, 108, 109

W

Wage and employment effects, 46
Wageningen, 332–340, 343–347, 350–353
Washington, 17, 191, 215
Welfare gain parameters, 42
West Africa Rice Development
 Association (WARDA), 191, 204, 280
West African Cocoa Research Institute, 272
West African Institute for Oil Palm
 Research, 272
West African Institute for Rice Research, 272
West African Institute for
 Trypanosomiasis Research, 272
West African Storage Products Research
 Institute, 272

Wheat, 5, 16–18, 73, 74, 84–86, 88,
 127, 188, 204, 209, 220, 269, 309,
 357, 369
Working group, 93, 219, 265
World Agroforestry Centre (ICRAF), 191
World bank, 17, 20, 22, 25, 30, 190–193,
 273–275, 277, 317, 350
World Food Programme (WFP), 188
Worldfish center, 191

Y

Yaqui valley, 73, 74

X

Zaria, 271, 272